

**DPP-01 : Basic Terminology, Construction of Electrochemical Cell and Its Representation**

1. In a galvanic cell
  - (1) chemical reaction produces electrical energy
  - (2) electrical energy produces chemical reaction
  - (3) reduction occurs at anode
  - (4) oxidation occurs at cathode
  
2. Which of the following statement is wrong about galvanic cell ?
  - (1) Cathode is positive charged
  - (2) Anode is negatively charged
  - (3) Reduction takes place at the anode
  - (4) Electrons move from anode to cathode
  
3. Which of the following has been universally accepted as a reference electrode at all temperatures and has been assigned a value of zero volt?
  - (1) Standard platinum electrode
  - (2) Standard copper electrode
  - (3) Standard graphite electrode
  - (4) Standard hydrogen electrode
  
4. Which is not true for a standard hydrogen electrode ?
  - (1) The hydrogen ion concentration is 1 M
  - (2) Temperature must be 25°C
  - (3) Pressure of hydrogen is 1 atmosphere
  - (4) All are correct
  
5. The equation representing the process by which standard reduction potential of zinc can be defined is :
  - (1)  $Zn^{2+}(s) + 2e^{-} \longrightarrow Zn(s)$
  - (2)  $Zn(g) \longrightarrow Zn^{2+}(g) + 2e^{-}$
  - (3)  $Zn^{2+}(g) + 2e^{-} \longrightarrow Zn(s)$
  - (4)  $Zn^{2+}(aq.) + 2e^{-} \longrightarrow Zn(s)$
  
6. KCl can be used in salt bridge as electrolyte in which of the following cells?
  - (1)  $Zn | ZnCl_2 || AgNO_3 | Ag$
  - (2)  $Pb | Pb(NO_3)_2 || Cu(NO_3)_2 | Cu$
  - (3)  $Cu | CuSO_4 || AuCl_3 | Au$
  - (4)  $Fe | FeSO_4 || Pb(NO_3)_2 | Pb$
  
7. For the cell reaction  $2Ag^{+}(aq) + H_2(g) \rightarrow 2H^{+}(aq) + 2Ag(s)$ . Correct IUPAC cell notation is :
  - (1)  $Pt | H_2 | H^{+} || Ag^{+} | Ag$
  - (2)  $Ag | Ag^{+} || H^{+} | H_2 | Pt$
  - (3)  $Ag^{+} | Ag || H^{+} | H_2 | Pt$
  - (4)  $Pt | H^{+} | H_2 || Ag^{+} | Ag$

**DPP-02 : Electrochemical Series and its applications**

1. A correct electrochemical series can be obtained from K, Ca, Na, Al, Mg, Zn, Fe, Pb, H, Cu, Hg, Au, by interchanging :
  - (1) Al and Mg
  - (2) Zn and Fe
  - (3) Zn and Pb
  - (4) Pb and H
  
2. The  $E^{\circ}_{M^{3+}/M^{2+}}$  values for Cr, Mn, Fe and Co are – 0.41, + 1.57, + 0.77 and +1.97 V respectively. For which one of these metals the change in oxidation state from +2 to +3 is easiest?
  - (1) Co
  - (2) Mn
  - (3) Fe
  - (4) Cr
  
3. The standard reduction potential at 25°C of  $Li^{+}/Li$ ,  $Ba^{2+}/Ba$ ,  $Na^{+}/Na$  and  $Mg^{2+}/Mg$  are – 3.05, –2.73, –2.71 and – 2.37 volt respectively. Which one of the following is the strongest oxidising agent ?
  - (1)  $Na^{+}$
  - (2)  $Li^{+}$
  - (3)  $Ba^{2+}$
  - (4)  $Mg^{2+}$

4. Standard reduction electrode potentials of three metals A, B and C are +0.5 V, -3.0 V and -1.2 V respectively. The reducing power of these metals are :  
 (1) B > C > A                      (2) A > B > C                      (3) C > B > A                      (4) A > C > B
5. Given :  $E^\circ(\text{Cu}^{2+} | \text{Cu}) = 0.337 \text{ V}$  and  $E^\circ(\text{Sn}^{2+} | \text{Sn}) = -0.136 \text{ V}$ . Which of the following statements is correct?  
 (1)  $\text{Cu}^{2+}$  ions can be reduced by  $\text{H}_2(\text{g})$                       (2) Cu can be oxidized by  $\text{H}^+$   
 (3)  $\text{Sn}^{2+}$  ions can be reduced by  $\text{H}_2(\text{g})$                       (4) Cu can reduce Sn
6. Zn can not displace following ions from their aqueous solution :  
 (1)  $\text{Ag}^+$                       (2)  $\text{Cu}^{2+}$                       (3)  $\text{Fe}^{2+}$                       (4)  $\text{Na}^+$
7. Which of the following displacement does not occur :  
 (1)  $\text{Zn} + 2\text{H}^+ \rightarrow \text{Zn}^{2+} + \text{H}_2$                       (2)  $\text{Fe} + 2\text{Ag}^+ \rightarrow \text{Fe}^{2+} + 2\text{Ag}$   
 (3)  $\text{Cu} + \text{Fe}^{2+} \rightarrow \text{Cu}^{2+} + \text{Fe}$                       (4)  $\text{Zn} + \text{Pb}^{2+} \rightarrow \text{Zn}^{2+} + \text{Pb}$
8. The metal that cannot be produced on reduction of its oxide by aluminium is :  
 (1) K                      (2) Mn                      (3) Cr                      (4) Fe
9. Consider the following sets :

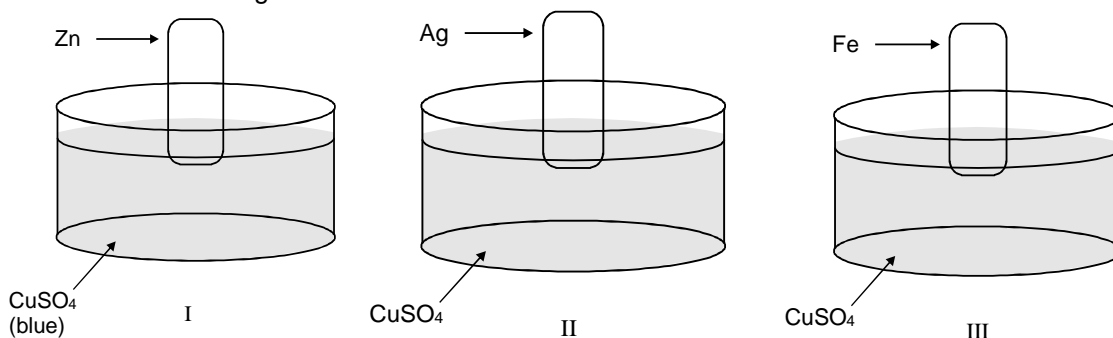

Blue colour solution changes to colourless (or fades) in :

- (1) I, II, III                      (2) I, II                      (3) II, III                      (4) I, III

10. Consider the following sets

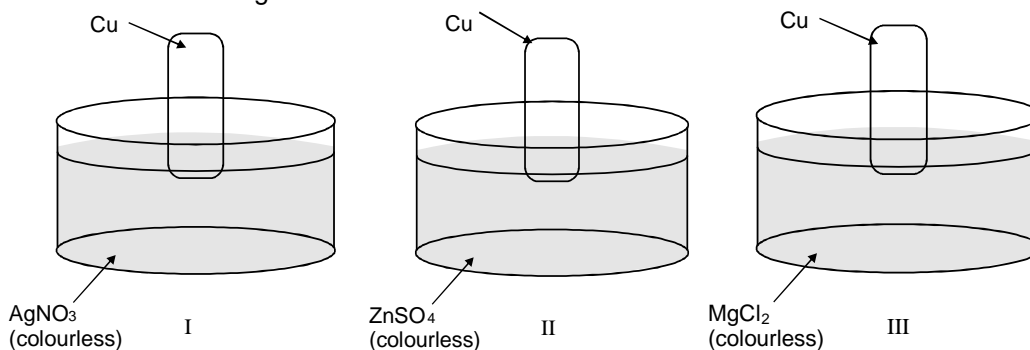

colourless solution changes to blue coloured solution in :

- (1) I                      (2) II                      (3) III                      (4) I, III

### DPP-03 : Concept of $\Delta G^\circ$

1.  $E^\circ$  for  $\text{F}_2 + 2\text{e} \rightarrow 2\text{F}^-$  is 2.8 V,  $E^\circ$  for  $\frac{1}{2}\text{F}_2 + \text{e} \rightarrow \text{F}^-$  is  
 (1) 2.8 V                      (2) 1.4 V                      (3) -2.8 V                      (4) -1.4 V

2. The standard oxidation potentials, for the given half reactions is as :  
 $\text{Fe} \longrightarrow \text{Fe}^{2+} + 2\text{e}^-$  ;  $E^{\circ} = + 0.41 \text{ V}$   
 then standard electrode potential for the reaction  $2\text{Fe}^{2+} + 4\text{e}^- \rightarrow 2\text{Fe}$  will be  
 (1) +0.41 (2) + 0.82 (3) - 0.41 (4) - 0.82
3. The oxidation potential of Zn, Cu, Ag,  $\text{H}_2$  and Ni are 0.76, - 0.34, - 0.80, 0, 0.55 volt respectively.  
 Which of the following reaction will provide maximum voltage ?  
 (1)  $\text{Zn} + \text{Cu}^{2+} \longrightarrow \text{Cu} + \text{Zn}^{2+}$  (2)  $\text{Zn} + 2\text{Ag}^+ \longrightarrow 2\text{Ag} + \text{Zn}^{2+}$   
 (3)  $\text{H}_2 + \text{Cu}^{2+} \longrightarrow 2\text{H}^+ + \text{Cu}$  (4)  $\text{H}_2 + \text{Ni}^{2+} \longrightarrow 2\text{H}^+ + \text{Ni}$
4. The standard electrode potential for the reaction  $\text{Ag}^+ (\text{aq}) + \text{e}^- \longrightarrow \text{Ag}(\text{s})$   
 $\text{Sn}^{2+}(\text{aq}) + 2\text{e}^- \longrightarrow \text{Sn}(\text{s})$  at  $25^{\circ}\text{C}$  are 0.80 volt and - 0.14 volt, respectively. The emf of the cell.  
 $\text{Sn} | \text{Sn}^{2+}(1\text{M}) || \text{Ag}^+(1\text{M}) | \text{Ag}$  is :  
 (1) 0.66 volt (2) 0.80 volt (3) 1.08 volt (4) 0.94 volt
5. If  $E^{\circ}_{\text{Fe}^{2+}/\text{Fe}} = - 0.441 \text{ V}$  and  $E^{\circ}_{\text{Fe}^{3+}/\text{Fe}^{2+}} = 0.771 \text{ V}$ , the standard EMF of the reaction  
 $\text{Fe} + 2\text{Fe}^{3+} \longrightarrow 3\text{Fe}^{2+}$   
 will be:  
 (1) 1.212 V (2) 0.111 V (3) 0.330 V (4) 1.653 V
6. The standard electrode potentials of the two half cell are given below :  
 $\text{Ni}^{2+} + 2\text{e}^- \longrightarrow \text{Ni}$  ;  $E^{\circ} = - 0.25 \text{ V}$   
 $\text{Zn}^{2+} + 2\text{e}^- \longrightarrow \text{Zn}$  ;  $E^{\circ} = - 0.77 \text{ V}$   
 The emf of cell formed by combining the two half cells would be :  
 (1) - 1.02 volt (2) + 0.52 volt (3) + 1.02 volt (4) - 0.52 volt
7. If  $E^{\circ}_{\text{Cu}^+/\text{Cu}} = 0.52\text{V}$ ,  $E^{\circ}_{\text{Cu}^{2+}/\text{Cu}} = 0.34\text{V}$  , what is  $E^{\circ}_{\text{cell}}$  of the cell reaction  $\text{Cu} + \text{Cu}^{2+} \rightarrow 2\text{Cu}^+$  ?  
 Is cell reaction spontaneous ?  
 (1) -0.36 (2) 0.18 V (3) - 0.86 (4) + 0.86
8. For the fuel-cell reaction,  $2\text{H}_2 + \text{O}_2 \rightarrow 2\text{H}_2\text{O}$ ,  $\Delta G^{\circ} = - 475 \text{ kJ}$ . Hence,  $E^{\circ}_{\text{cell}}$  is :  
 (1) 1.23 V (2) 2.46 V (3) 0.615 V (4) 0.31 V

#### DPP-04 : Nernst Equation and it's Application in Different type of Electrodes and Cells

1. For a reaction,  $\text{M}^{n+1} + \text{ne}^- \longrightarrow \text{M}^{n+}$ , the Nernst equation has a form of :  
 (1)  $E = E^{\circ} + \frac{RT}{nF} \ln \frac{[\text{M}^{n+}]}{[\text{M}^{n+1}]}$  (2)  $E = E^{\circ} - \frac{RT}{nF} \ln \frac{[\text{M}^{n+}]}{[\text{M}^{n+1}]}$   
 (3)  $E = E^{\circ} - \frac{RT}{nF} \log \frac{[\text{M}^{n+}]}{[\text{M}^{n+1}]}$  (4)  $E = E^{\circ} + \frac{RT}{nF} \log \frac{[\text{M}^{n+}]}{[\text{M}^{n+1}]}$
2. Which of the following represents the potential of a silver wire dipped in to 0.1 M  $\text{AgNO}_3$  solution at  $25^{\circ}\text{C}$  ?  
 (1)  $E^{\circ}_{\text{red}}$  (2)  $(E^{\circ}_{\text{red}} + 0.059)$  (3)  $(E^{\circ}_{\text{OX}} - 0.059)$  (4)  $(E^{\circ}_{\text{red}} - 0.059)$

3. The emf of the cell  
 $\text{Ti} / \text{Ti}^+ (0.01\text{M}) \parallel \text{Cu}^{2+}(0.1\text{M}) / \text{Cu}$  is 0.83 V  
 The emf of this cell will be increased by :  
 (1) Increase the concentration of  $\text{Cu}^{++}$  ions (2) Decreasing the concentration of  $\text{Ti}^+$   
 (3) Increasing the concentration of both (4) (1) & (2) both
4. The reduction potential of hydrogen electrode at  $25^\circ\text{C}$  will be ( $P_{\text{H}_2} = 1 \text{ atm}$  ;  $[\text{H}^+] = 0.1 \text{ M}$ )—  
 (1) 0.00 V (2)  $-0.059 \text{ V}$  (3) 0.118 V (4) 0.059 V
5. What is the electrode potential (in V) of the following electrode at  $25^\circ\text{C}$  ?  
 $\text{Ni}^{2+}(0.1 \text{ M}) \mid \text{Ni}(\text{s})$   
 (Standard reduction potential of  $\text{Ni}^{2+} \mid \text{Ni}$  is  $-0.25 \text{ V}$ ,  $\frac{2.303}{F} \frac{RT}{F} = 0.06$ )  
 (1)  $-0.28 \text{ V}$  (2)  $-0.34 \text{ V}$  (3)  $-0.82 \text{ V}$  (4)  $-0.22 \text{ V}$
6. Find the emf of the Given,  $E^\circ \text{Pb}^{2+} / \text{Pb} = -0.12 \text{ V}$  ;  $E^\circ \text{Zn}^{2+} / \text{Zn} = -0.76\text{V}$ .  
 cell  $\text{Zn} / \text{Zn}^{2+} (0.1 \text{ M}) \parallel \text{Pb}^{2+} (1 \text{ M}) \mid \text{Pb}$ .  
 (1)  $-0.637$  (2)  $+0.637$  (3)  $> 0.637$  (4)  $+0.889$
7. For the redox reaction :  
 $\text{Zn}(\text{s}) + \text{Cu}^{2+} (0.1 \text{ M}) \rightarrow \text{Zn}^{2+} (1 \text{ M}) + \text{Cu}(\text{s})$   
 taking place in a cell,  $E^\circ_{\text{cell}}$  is 1.10 volt.  $E_{\text{cell}}$  for the cell will be :  $\left( \frac{2.303}{F} \frac{RT}{F} = 0.0591 \right)$   
 (1) 2.14 V (2) 1.80 V (3) 1.07 V (4) 0.82 V
8. For a reaction  $\text{A}(\text{s}) + 2\text{B}^+(\text{al}) \rightleftharpoons (\text{ag})\text{A}^{2+} + 2\text{B}(\text{s})$   $K_C$  has been found to be  $10^{12}$ . The  $E^\circ$  cell is :  
 (1) 0.354 V (2) 0.708 V (3) 0.0098 V (4) 1.36 V
9. By how much will the potential of half cell  $\text{Cu}^{2+} / \text{Cu}$  change if the solution is diluted to 100 times at 298 K  
 (1) Increases by 59 mV (2) Decreases by 59 mV  
 (3) Increases by 29.5 mV (4) Decreases by 29.5 mV
10. Which represent a concentration cell ?  
 (1)  $\text{Pt} \mid \text{H}_2 \mid \text{HCl} \parallel \text{HCl} \mid \text{Pt} \mid \text{H}_2$  (2)  $\text{Pt} \mid \text{H}_2 \mid \text{HCl} \parallel \text{Cl}_2 \mid \text{Pt}$   
 (3)  $\text{Zn} \mid \text{Zn}^{2+} \parallel \text{Cu}^{2+} \mid \text{Cu}$  (4)  $\text{Fe} \mid \text{Fe}^{+2} \parallel \text{Cu}^{2+} \mid \text{Cu}$
11.  $\text{Zn} \mid \text{Zn}^{2+} (C_1) \parallel \text{Zn}^{2+} (C_2) \mid \text{Zn}$ . for this cell  $\Delta G$  is negative if -  
 (1)  $C_1 = C_2$  (2)  $C_1 > C_2$  (3)  $C_2 > C_1$  (4) None

### DPP-05 : Electrolysis

1. Which of the substances Na, Hg, S, Pt and graphite can be used as inert electrodes in electrolytic cells having aqueous solution ?  
 (1) Hg and Pt (2) Hg, Pt and graphite (3) Na, S (4) Na, Hg, S
2. By the electrolysis of aqueous solution of  $\text{CuSO}_4$ , the products obtained at both the electrodes are  
 (1)  $\text{O}_2$  at anode and  $\text{H}_2$  at cathode (2)  $\text{H}_2$  at anode and Cu at cathode  
 (3)  $\text{O}_2$  at anode and Cu at cathode (4)  $\text{H}_2\text{S}_2\text{O}_8$  at anode and  $\text{O}_2$  at cathode

3. A spoon to be electroplated with gold should be :  
 (1) cathode (2) anode (3) electrolyte (4) none of these
4. During the electrolysis of fused NaCl, the reaction that occurs at the anode is :  
 (1) Chloride ions are oxidized (2) Chloride ions are reduced  
 (3) Sodium ions are oxidized (4) Sodium ions are reduced
5. In electrolysis of dilute  $\text{H}_2\text{SO}_4$ , what is liberated at anode ?  
 (1)  $\text{H}_2$  (2)  $\text{SO}_4^{2-}$  (3)  $\text{SO}_2$  (4)  $\text{O}_2$
6. An acidic solution of copper (II) sulphate containing some contaminations of zinc and iron (II) ions was electrolysed till all the copper is deposited. If electrolysis is further continued for sometime, the product liberated at cathode is  
 (1) Fe (2) Zn (3)  $\text{H}_2$  (4) Alloy of Zn and Fe.
7. During electrolysis of fused calcium hydride, the hydrogen is produced at :  
 (1) Cathode (2) Anode  
 (3) Hydrogen is no liberated at all (4)  $\text{H}_2$  produced reacts with oxygen to form water
8. The passage of current liberates  $\text{H}_2$  at cathode and  $\text{Cl}_2$  at anode the solution :  
 (1)  $\text{CuSO}_4$  (aq) (2)  $\text{CuCl}_2$  (aq.) (3)  $\text{NaCl}$ (aq.) (4) Water
9. At cathode, the electrolysis of aqueous  $\text{Na}_2\text{SO}_4$  gives :  
 (1) Na (2)  $\text{H}_2$  (3)  $\text{SO}_3$  (4)  $\text{SO}_2$
10. A solution containing one mole per litre of each  $\text{Cu}(\text{NO}_3)_2$ ;  $\text{AgNO}_3$ ;  $\text{Hg}_2(\text{NO}_3)_2$ ;  $\text{Mg}(\text{NO}_3)_2$  is being electrolysed by using inert electrodes. The values of standard electrode potentials in volts (reduction potentials) are:  
 $\text{Ag}^+/\text{Ag} = + 0.80 \text{ V}$ ,  $\text{Hg}^{++}/\text{Hg}_2 = + 0.79 \text{ V}$ ,  $\text{Cu}^{++}/\text{Cu} = + 0.34 \text{ V}$ ,  $\text{Mg}^{++}/\text{Mg} = - 2.37 \text{ V}$   
 With increasing voltage, the sequence of deposition of metals on the cathode will be :  
 (1) Ag, Hg, Cu, Mg (2) Mg, Cu, Hg, Ag (3) Ag, Hg, Cu (4) Cu, Hg, Ag

### DPP-06 : Faradays Law of Electrolysis

1. The electric charge for electrode deposition of one gram equivalent of a substance is :  
 (1) one amp /sec (2) 96,500 C / sec (3) one amp / hour (4) 96,500 C
2. The amount of an ion discharged during electrolysis is not directly proportional to :  
 (1) resistance (2) time duration of electrolysis  
 (3) charge (4) electrochemical equivalent of the element
3. Which one is the correct equation that represents the first law of electrolysis ?  
 ( $w \rightarrow$  mass,  $i \rightarrow$  current,  $t \rightarrow$  time)  
 (1)  $wz = it$  (2)  $w = izt$  (3)  $wi = zt$  (4)  $i = wzt$
4. When the same electric current is passed through the solution of different electrolytes in series the amounts of elements deposited on the electrodes are in the ratio of their :  
 (1) atomic number (2) atomic masses (3) specific gravities (4) equivalent masses

5. Faraday's law of electrolysis fails when :  
 (1) Temperature is increased (2) Inert electrodes are used  
 (3) A mixture of electrolytes is used (4) In none of the above cases
6. An ion is reduced to the element when it absorbs  $6 \times 10^{20}$  electrons. The number of equivalents of the ion is:  
 (1) 0.10 (2) 0.01 (3) 0.001 (4) 0.0001
7. Electro chemical equivalent of a substance is 0.0006735 ; its eq. wt. is :  
 (1) 65 (2) 67.35 (3) 130 (4) cannot be calculated
8. How many faradays are required to reduce one mol of  $\text{MnO}_4^-$  to  $\text{Mn}^{2+}$  -  
 (1) 1 (2) 2 (3) 3 (4) 5
9. The amount of electricity that can deposit 108 g. of silver from silver nitrate solution is :  
 (1) 1 ampere (2) 1 coulomb (3) 1 Faraday (4) 2 ampere
10. The moles of electrons required to deposit 1 gm equivalent aluminium (at. wt. = 27) from a solution of aluminium chloride will be  
 (1) 3 (2) 1 (3) 4 (4) 2
11. A current of 9.65 amp. flowing for 10 minute deposits 3.0 g of a metal. The equivalent wt. of the metal is  
 (1) 10 (2) 30 (3) 50 (4) 96.5
12. W g of copper deposited in a copper voltameter when an electric current of 2 ampere is passed for 2 hours. If one ampere of electric current is passed for 4 hours in the same voltameter, copper deposited will be :  
 (1) W (2) W/2 (3) W/4 (4) 2W
13. How many minutes will it take to plate out 5.0 g of Cr from a  $\text{Cr}_2(\text{SO}_4)_3$  solution using a current of 1.50 A ? (Atomic weight : Cr = 52.0)  
 (1) 254 (2) 309 (3) 152 (4) 103
14. A current of 9.95 amp following for 10 minutes, deposits 3 gm of a metal. Equivalent weight of the metal is  
 (1) 12.5 (2) 18.5 (3) 21.5 (4) 48.5
15. An electrolysis of a oxytungsten complex ion using 1.10 A for 40 min produces 0.838 g of tungsten. What is the charge of tungsten in the material ? (Atomic weight : W = 184)  
 (1) 6 (2) 2 (3) 4 (4) 1
16. The ratio of weights of hydrogen and magnesium deposited by the same amount of electricity from aqueous  $\text{H}_2\text{SO}_4$  and fused  $\text{MgSO}_4$  are :  
 (1) 1 : 8 (2) 1 : 12 (3) 1 : 16 (4) None of these
17. Silver is removed electrolytically from 200 ml. of a 0.1 N solution of  $\text{AgNO}_3$  by a current of 0.1 ampere. How long will it take to remove half of the silver from the solution :  
 (1) 10 sec. (2) 16 sec. (3) 100 sec. (4) 9650 sec.
18. The weight ratio of Al and Ag deposited using the same quantity of current is:  
 (1) 9 : 108 (2) 2 : 12 (3) 108 : 9 (4) 3 : 8

19. When molten lithium chloride (LiCl) is electrolyzed, lithium metal is formed at the cathode. If current efficiency is 75% then how many grams of lithium are liberated when 1930 C of charge pass through the cell : (Atomic weight : Li = 7)
- (1) 0.105                      (2) 0.120                      (3) 0.28                      (4) 0.240

### DPP-07 : Commercial Cells & Corrosion

1. When a lead storage battery is discharged  
 (1) PbSO<sub>4</sub> is formed      (2) Pb is formed      (3) SO<sub>2</sub> is consumed      (4) H<sub>2</sub>SO<sub>4</sub> is formed
2. During discharging of a lead storage cell the density of sulphuric acid in the cell :  
 (1) Increasing                      (2) decreasing  
 (3) remains unchanged              (4) initially increases but decrease subsequently
3. In H<sub>2</sub> – O<sub>2</sub> fuel cell the reaction occurring at cathode is :  
 (1) 2 H<sub>2</sub>O + O<sub>2</sub> + 4 e<sup>-</sup> → 4 OH<sup>-</sup>              (2) 2 H<sub>2</sub> + O<sub>2</sub> → 2 H<sub>2</sub>O (l)  
 (3) H<sup>+</sup> + OH<sup>-</sup> → H<sub>2</sub>O              (4) H<sup>+</sup> + e<sup>-</sup> →  $\frac{1}{2}$  H<sub>2</sub>.
4. Which process involves corrosion ?  
 (1) Brown deposits on iron articles              (2) Green deposits on battery terminals  
 (3) Black deposits on silver coin              (4) All of the above

### DPP-08 : Electrolytic Conductance (Basic Definitions)

1. The units of conductivity are  
 (1) ohm<sup>-1</sup>                      (2) ohm<sup>-1</sup> cm<sup>-1</sup>                      (3) ohm<sup>-2</sup> cm<sup>2</sup> equiv<sup>-1</sup>      (4) ohm<sup>-1</sup> cm<sup>2</sup>
2. If the specific resistance of a solution of concentration C g equivalent litre<sup>-1</sup> is R, then its equivalent conductance is :  
 (1)  $\frac{100 R}{C}$                       (2)  $\frac{RC}{1000}$                       (3)  $\frac{1000}{RC}$                       (4)  $\frac{C}{1000R}$
3. The specific conductance of a N/10 KCl at 25°C is 0.0112 ohm<sup>-1</sup> cm<sup>-1</sup>. The resistance of cell containing solution at the same temperature was found to be 55 ohms. The cell constant will be  
 (1) 6.16 cm<sup>-1</sup>                      (2) 0.616 cm<sup>-1</sup>                      (3) 0.0616 cm<sup>-1</sup>                      (4) 616 cm<sup>-1</sup>
4. The specific conductance of a salt of 0.01 M concentration is 1.061 × 10<sup>-4</sup> Ω<sup>-1</sup> cm<sup>-1</sup> molar conductance of the same solution will be :  
 (1) 1.061 × 10<sup>-4</sup>                      (2) 1.061                      (3) 10.61                      (4) 106.1
5. Which of the following solutions of NaCl will have the highest specific conductance ?  
 (1) 0.001 N                      (2) 0.1 N                      (3) 0.01 N                      (4) 1.0 N

### DPP-09 : Kohlrausch law and its applications

1. At 18°C, the equivalent conductance of H<sup>+</sup> and CH<sub>3</sub>COO<sup>-</sup> at infinite dilution are 315 and 35 mho cm<sup>2</sup> eq<sup>-1</sup> respectively. The equivalent conductivity of CH<sub>3</sub>COOH at infinite dilution is .....mho cm<sup>2</sup> eq<sup>-1</sup>  
 (1) 350                      (2) 280                      (3) 30                      (4) 315

2. The molar conductance at infinite dilution of  $\text{AgNO}_3$ ,  $\text{AgCl}$  and  $\text{NaCl}$  are 116.5, 121.6 and 110.3 respectively. The molar conductances of  $\text{NaNO}_3$  is :  
 (1) 111.4                      (2) 105.2                      (3) 130.6                      (4) 150.2
3. At infinite dilution, the eq. conductance of  $\text{CH}_3\text{COONa}$ ,  $\text{HCl}$  and  $\text{CH}_3\text{COOH}$  are 91, 426 and 391 mho  $\text{cm}^2$  respectively at  $25^\circ\text{C}$ . The eq. conductance of  $\text{NaCl}$  at infinite dilution will be :  
 (1) 126                      (2) 209                      (3) 391                      (4) 908
4. The value of  $\lambda_m^\infty$  for  $\text{NH}_4\text{Cl}$ ,  $\text{NaOH}$  and  $\text{NaCl}$  are 129.8, 248.1 and 126.4  $\text{ohm}^{-1} \text{cm}^2 \text{mol}^{-1}$  respectively. Calculate  $\lambda_m^\infty$  for  $\text{NH}_4\text{OH}$  solution (in  $\text{ohm}^{-1} \text{cm}^2 \text{mol}^{-1}$ )  
 (1) 215.5                      (2) 251.5                      (3) 244.7                      (4) 351.5
5. The equivalent conductivity of 0.1 N  $\text{CH}_3\text{COOH}$  at  $25^\circ\text{C}$  is 80 and at infinite dilution 400. The degree of dissociation of  $\text{CH}_3\text{COOH}$  is :  
 (1) 1                      (2) 0.2                      (3) 0.1                      (4) 0.5
6. The specific conductance of a 0.01 M solution of  $\text{KCl}$  is  $0.0014 \text{ohm}^{-1} \text{cm}^{-1}$  at  $25^\circ\text{C}$ . its equivalent conductance ( $\text{cm}^2 \text{ohm}^{-1} \text{equiv}^{-1}$ ) is :  
 (1) 140                      (2) 14                      (3) 1.4                      (4) 0.14
7. The ionization constant of a weak electrolyte is  $25 \times 10^{-6}$  while the equivalent conductance of its 0.01 M solution is  $19.6 \text{S cm}^2 \text{eq}^{-1}$ . The equivalent conductance of the electrolyte at infinite dilution (in  $\text{S cm}^2 \text{eq}^{-1}$ ) will be  
 (1) 250                      (2) 196                      (3) 392                      (4) 384

# Answers

---

---

## DPP-01

1. (1) 2. (3) 3. (4) 4. (4) 5. (4) 6. (3) 7. (1)

## DPP-02

1. (1) 2. (4) 3. (4) 4. (1) 5. (1) 6. (4) 7. (3)  
8. (1) 9. (4) 10. (1)

## DPP-03

1. (1) 2. (3) 3. (2) 4. (4) 5. (1) 6. (2) 7. (1)  
8. (1)

## DPP-04

1. (2) 2. (4) 3. (4) 4. (2) 5. (1) 6. (3) 7. (3)  
8. (1) 9. (2) 10. (1) 11. (3)

## DPP-05

1. (2) 2. (3) 3. (1) 4. (1) 5. (4) 6. (3) 7. (2)  
8. (3) 9. (2) 10. (3)

## DPP-06

1. (4) 2. (1) 3. (2) 4. (4) 5. (4) 6. (3) 7. (1)  
8. (4) 9. (3) 10. (2) 11. (3) 12. (1) 13. (2) 14. (4)  
15. (1) 16. (2) 17. (4) 18. (1) 19. (1)

## DPP-07

1. (1) 2. (2) 3. (1) 4. (4)

## DPP-08

1. (2) 2. (3) 3. (2) 4. (3) 5. (4)

## DPP-09

1. (1) 2. (2) 3. (1) 4. (2) 5. (2) 6. (1) 7. (3)

---