



Complete Course on Chemical Technology

Use Code: DEVENDRAPOONIA to get 10% off on Plus Subscription

Q(1). Which one of the following is NOT CORRECT?

(A) nylon-6,6 is produced by condensation polymerization

(B) phenol-formaldehyde resin is a thermosetting polymer

(C) high density polyethylene (HDPE) is produced by condensation polymerization

(D) poly(ethylene terephthalate) (PET) is a polyester

(GATE 2020)

Use Code: DEVENDRAPOONIA to get 10% off on Plus Subscription

Ans:- (C) high density polyethylene (HDPE) is produced by condensation polymerization

Nylon 66 :-

➤ **Monomers-**

(i) hexamethylene diamine (HMD)

(ii) adipic acid

➤ **Reaction:-**

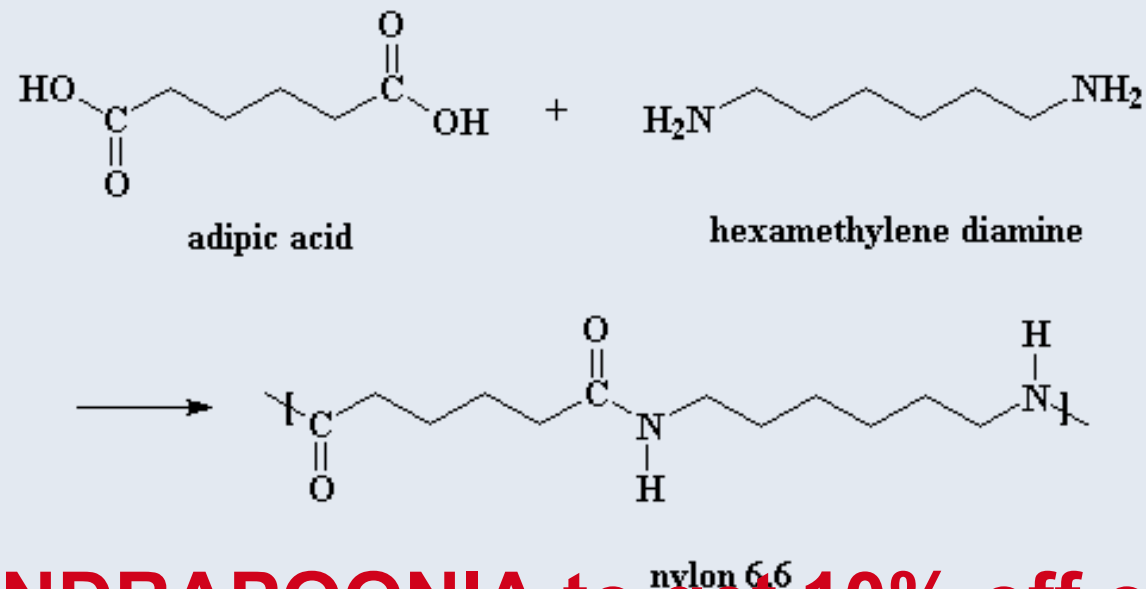

S.No	Addition Polymerization	Condensation polymerization
1.	Monomer must have at least a double bond or triple bond	Monomer must have at least two similar or different functional group
2.	Has no by product	Produces by products such as water, ammonia, HCl
3.	Addition of monomer results in a polymer	Monomers condensed to give a polymer
4.	Produces thermoplastics	Produces thermosets
5.	Results in homochain polymers	Results in hetero-chain polymers
6.	Examples:-polyvinyl chloride (PVC), polyethylene, polypropylene, poly tetrafluoroethen or TEFLON, etc.	Examples:- Bakelite, nylon, polyester(PET) etc.

Use Code: DEVENDRAPOONIA to get 10% off on Plus Subscription

Polymer	Reactant	Branching	Types of polymerization	catalyst	Temperature (°C)	Pressure, (atm)
HDPE	Ethylene	Very few branches	Solution or bulk, tubular reactor, liquid phase	H ₂ O ₂	200-240	3500
LDPE	Ethylene	Short and regular branches	Suspension, stirred tank reactor, liquid phase	TiCl ₄	60-80	20-35
LLDPE	Ethylene & 1-butene	High branching with both short and long chain branches	Suspension, fluidized bed reactor, vapour phase	TiCl ₄	100	7-20

Use Code: DEVENDRAPOONIA to get 10% off on Plus Subscription

Polyethylene Terephthalate:-

- Also known as - PET, PETE, Dacron, Terylene
- Catalyst - Antimony
- Monomer- (i) Dimethyl terephthalate process - dimethyl terephthalate, ethylene glycol
(ii) Terephthalic acid process - terephthalic acid, ethylene glycol

Use Code: DEVENDRAPOONIA to get 10% off on Plus Subscription

Q(2). The operating temperature range for the Haber process is 350-500°C. It is used for the production of ammonia at

- (A) 20 MPa using Fe catalyst in an exothermic reaction
- (B) 0.1 MPa using Fe catalyst in an exothermic reaction
- (C) 20 MPa using Fe catalyst in an endothermic reaction
- (D) 20 MPa using zeolite catalyst in an endothermic reaction

(GATE 2020)

Ans :- (A) 20 MPa using Fe catalyst in an exothermic reaction

Haber Process:-

- The Haber Process combines nitrogen from the air with hydrogen derived mainly from natural gas (methane) into ammonia.



- The reaction is reversible and the production of ammonia is exothermic.
- The catalyst is actually slightly more complicated than pure iron. It has potassium hydroxide added to it as a promoter - a substance that increases its efficiency.

Q(3). Consider the refinery processes in Group-1 and the catalysts in Group – 2.

Group-1

(P) Hydrodesulfurization

(Q) Fluid catalytic cracking (FCC)

(R) Naphtha reforming

Group – 2

(I) Zeolites

(II) Pt/Al₂O₃

(III) Co-Mo/ Al₂O₃

The correct combination is

(A) P-II, Q-I, R-III

(B) P — III, Q- II, R-I

(C) P — III, Q- I, R-II

(D) P — I, Q-III, R-II

(GATE 2020)

Use Code: DEVENDRAPOONIA to get 10% off on Plus Subscription

Ans:-(C) P — III, Q- I, R-II

Hydrodesulfurization:-

- Hydrodesulfurization (HDS) is a catalytic chemical process widely used to remove sulfur (S) from natural gas and from refined petroleum products, such as gasoline or petrol, jet fuel, kerosene, diesel fuel, and fuel oils
- Important reason for removing sulfur from the naphtha streams within a petroleum refinery is that sulfur, even in extremely low concentrations, poisons the noble metal catalysts (platinum and rhenium) in the catalytic reforming units that are subsequently used to upgrade the octane rating of the naphtha streams.
- The industrial hydrodesulfurization processes include facilities for the capture and removal of the resulting hydrogen sulfide (H_2S) gas. In petroleum refineries, the hydrogen sulfide gas is then subsequently converted into byproduct elemental sulfur or sulfuric acid (H_2SO_4).

Use Code: DEVENDRAPOONIA to get 10% off on Plus Subscription

Fluidized Catalytic Cracking (FCC):-

- Important conversion process in petroleum refineries.
- High molecular weight long chain hydrocarbons are cracked into the small molecules like Gasoline.
- Raw Material – Heavy Gas oil or Vacuum gas oil.
- Final product – Low mol. wt. small chain HCs
- Catalyst used- zeolite

Process Flow Diagram of FCC:-

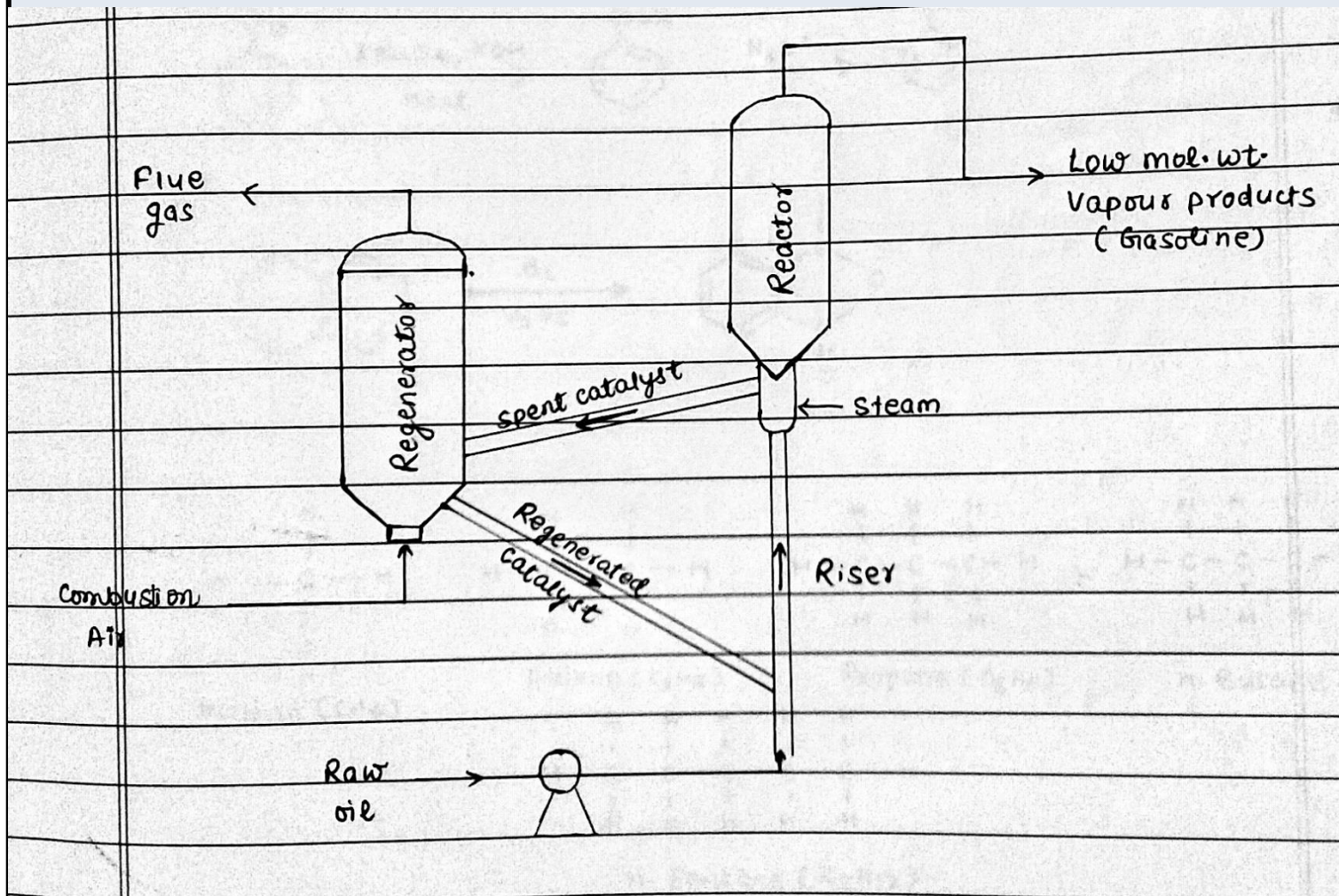

Key Points:-

- ❖ Regenerator- Exothermic Reaction
- ❖ Reactor- Endothermic Reaction
- ❖ Cracking reaction time – 2-4 sec

Catalytic Reforming:-

- The reforming process is a catalytic process which converts low octane naphthas into higher octane reformatate products.
- Process re-arranges or re-structures the hydrocarbon molecules in the naphtha feedstocks as well as breaking some of the molecules into smaller molecules.
- Among the same carbon number compounds, the order of RONC is (Research Octane Number) Paraffins < Naphthenes < Aromatics.
- Branched paraffins also have high octane. It increases with degree of branching.

REACTIONS IN CATALYTIC REFORMING:-

Desirable

- Dehydrogenation of naphthenes to aromatics.
- Isomerisation of paraffins and naphthenes.
- Dehydrocyclisation of paraffins to aromatics.

Non-Desirable

- Hydrocracking of paraffins to lower molecular weight compounds.

Q(4). Consider the processes in Group - 1 and the reactions in Group - 2.

Group – 1

P. Solvay process

Q. Oxo process

R. Saponification

Group 2

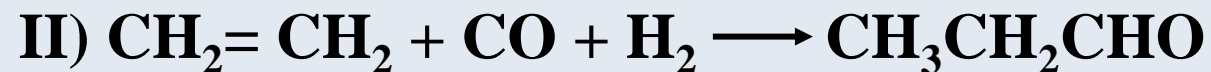
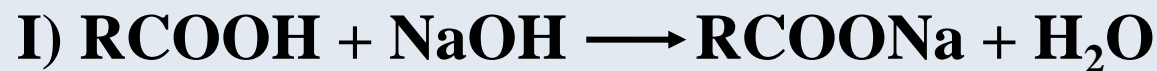

The correct combination is

(A) P-II, Q-I, R-III

(B) P-III, Q-II, R-I

(C) P-III, Q-I, R-II

(D) P-I, Q-III, R-II

(GATE 2020)

Use Code: DEVENDRAPOONIA to get 10% off on Plus Subscription

Ans:- (B) P-III, Q-II, R-I

Solvay Process:-

- The Solvay process or ammonia-soda process is the major industrial process for the production of sodium carbonate & sodium hydrogen carbonate.
- The ingredients for this process are readily available and inexpensive: salt brine (from inland sources or from the sea) and limestone (from mines).
- The Solvay process results in soda ash (Na_2CO_3) from brine (NaCl) and from limestone (CaCO_3).
- $2 \text{NaCl} + \text{CaCO}_3 \rightarrow \text{Na}_2\text{CO}_3 + \text{CaCl}_2$
- $\text{NaCl} + \text{CO}_2 + \text{NH}_3 + \text{H}_2\text{O} \rightarrow \text{NaHCO}_3 + \text{NH}_4\text{Cl}$

Use Code: DEVENDRAPOONIA to get 10% off on Plus Subscription

Propylene to Butanol (Oxo process):- Hydro formylation

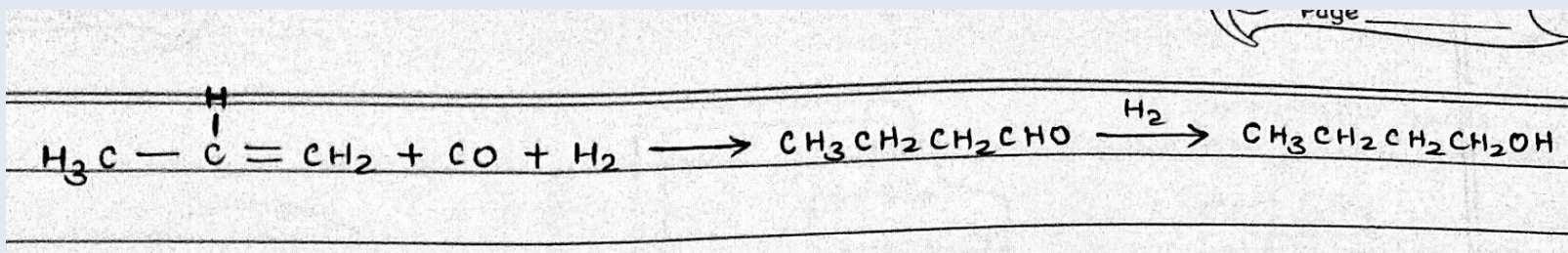

Use Code: DEVENDRAPOONIA to get 10% off on Plus Subscription

Saponification:-

- A mixture of tallow (animal fat), coconut oil, sodium hydroxide and salt are mixed in fixed proportion and fed to a reactor (Kettle or pan) with and heated with steam.
- The soap produced is the salt of a long chain carboxylic acid.

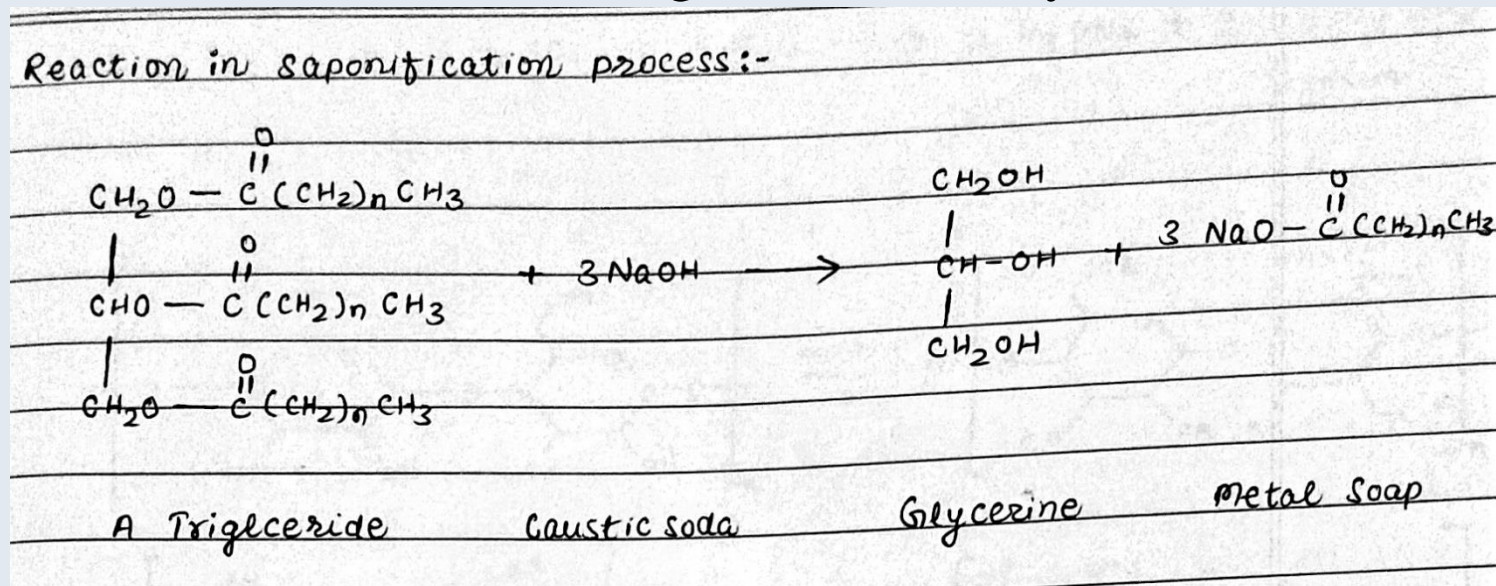

Q(5). Producer gas is obtained by

- (A) passing air through red hot coke
- (B) thermal cracking of naphtha
- (C) passing steam through red hot coke
- (D) passing air and steam through red hot coke

(GATE 2019)

Ans:- (D) passing air and steam through red hot coke

Producer gas is a combustible gas manufactured by blowing a mixture of steam and air upwards through a bed of hot coke, or coal, such that the fuel is completely gasified. The gas obtained from coke consists mainly of a mixture of carbon monoxide and hydrogen with the nitrogen from the blast of air.

Use Code: DEVENDRAPOONIA to get 10% off on Plus Subscription

Q(6). In Kraft process, the essential chemical reagents used in the digester are

(A) caustic soda, mercaptans and ethylene oxide

(B) caustic soda, sodium sulphide and soda ash

(C) quick lime, salt cake and dimethyl sulphide

(D) baking soda, sodium sulphide and mercaptans

(GATE 2019)

Use Code: DEVENDRAPOONIA to get 10% off on Plus Subscription

Ans:- (B) caustic soda, sodium sulphide and soda ash

- The kraft process (also known as kraft pulping or sulfate process) is a process for conversion of wood into wood pulp, which consists of almost pure cellulose fibers, the main component of paper.
- The kraft process entails treatment of wood chips with a hot mixture of water, sodium hydroxide (NaOH), and sodium sulfide (Na₂S), known as white liquor, that breaks the bonds that link lignin, hemicellulose, and cellulose. The technology entails several steps, both mechanical and chemical.
- It is the dominant method for producing paper.

Use Code: DEVENDRAPOONIA to get 10% off on Plus Subscription

Sulfate (Kraft) Pulping Process

- Most popularly used process.
- This is an alkaline process.
- Na_2SO_4 is added to the cooking liquor. So its common name is sulfate process.
- The presence of sodium sulfide makes bleaching of pulp easier and the paper produced has better strength.

Q(7). The most common catalyst used for oxidation of oxylene to phthalic anhydride is

(A) V_2O_5

(B) Pd

(C) Pt

(D) Ag

(GATE 2019)

Ans:- (A) V_2O_5

Oxidation of Naphthalene to Phthalic Anhydride:-

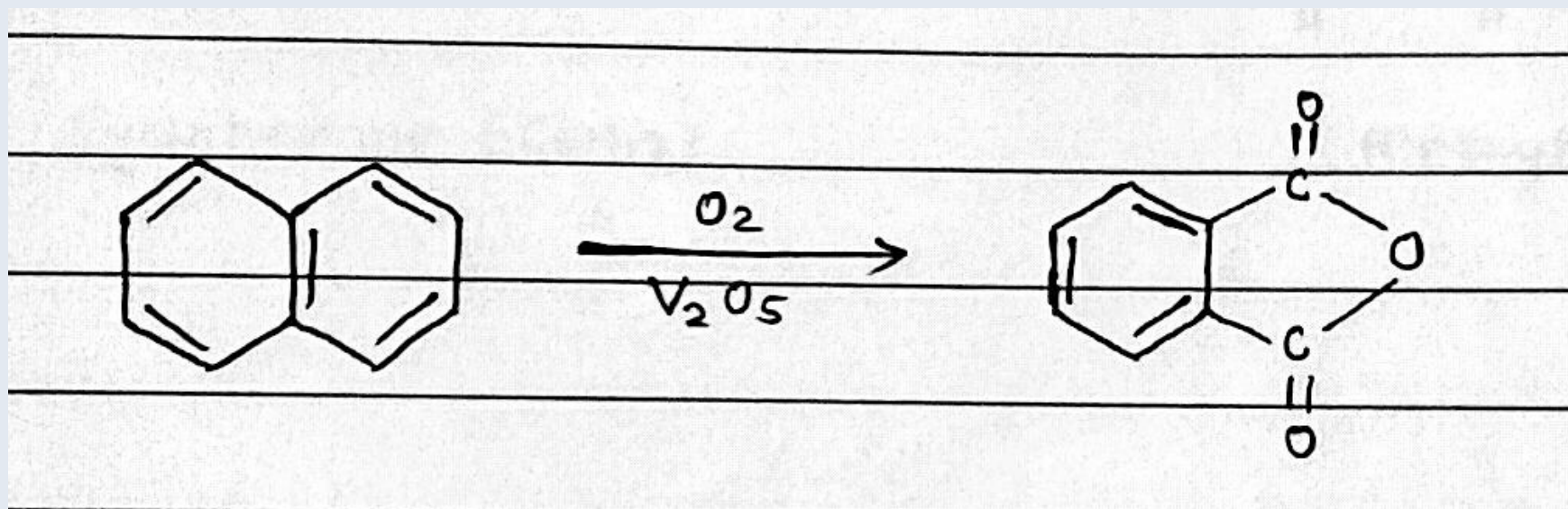

- Catalyst: Vanadium pentoxide.
- Reaction is highly exothermic.

Use Code: DEVENDRAPOONIA to get 10% off on Plus Subscription

Q(8). In petroleum refining operations, the process used for converting paraffins and naphthenes to aromatics is

(A) alkylation

(B) catalytic reforming

(C) hydrocracking

(D) isomerization

(GATE 2019)

Ans:- (A) Paraffins and naphthenes to aromatics

- The reforming process is a catalytic process which converts low octane naphthas into higher octane reformat products.
- Process re-arranges or re-structures the hydrocarbon molecules in the naphtha feedstocks as well as breaking some of the molecules into smaller molecules.
- Among the same carbon number compounds, the order of RONC is (Research Octane Number) Paraffins < Naphthenes < Aromatics.
- Branched paraffins also have high octane. It increases with degree of branching.

REACTIONS IN CATALYTIC REFORMING:-

Desirable

- Dehydrogenation of naphthenes to aromatics.
- Isomerisation of paraffins and naphthenes.
- Dehydrocyclisation of paraffins to aromatics.

Non-Desirable

- Hydrocracking of paraffins to lower molecular weight compounds.

Q(9). The combination that correctly matches the polymer in Group-1 with the polymerization reaction type in Group-2 is

Group-1

Group-2

P) Nylon 6

I) Condensation polymerization

Q) Polypropylene

II) Ring opening polymerization

R) Polyester

III) Addition polymerization

(A) P-II, Q-I, R-III

(B) P-I, QIII, R-II

(C) P-III, Q-II, R-I

(D) P-II, Q-III, R-I

(GATE 2019)

Use Code: DEVENDRAPOONIA to get 10% off on Plus Subscription

S.No	Addition Polymerization	Condensation polymerization
1.	Monomer must have at least a double bond or triple bond	Monomer must have at least two similar or different functional group
2.	Has no by product	Produces by products such as water, ammonia, HCl
3.	Addition of monomer results in a polymer	Monomers condensed to give a polymer
4.	Produces thermoplastics	Produces thermosets
5.	Results in homochain polymers	Results in hetero-chain polymers
6.	Examples:-polyvinyl chloride (PVC), polyethylene, polypropylene, poly tetrafluoroethen or TEFLON, etc.	Examples:- Bakelite, nylon, polyester(PET) etc.

Use Code: DEVENDRAPOONIA to get 10% off on Plus Subscription

Nylon 6:-

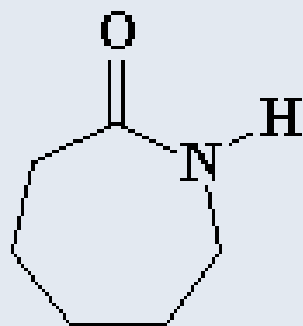

ϵ -caprolactam

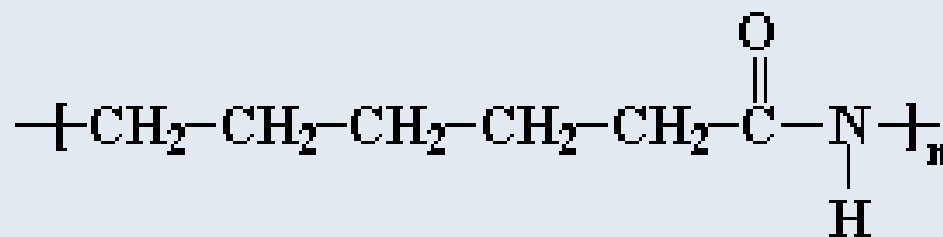

nylon 6

Q(10). The combination that correctly matches the process in Group-1 with the entries in Group-2 is

Group-1

P) Wulff process

Q) Sulfite process

R) Solvay process

S) Frasch process

(A) P- II, Q- IV, R-III, S-I

(B) P- III, Q- IV, R-II, S-I

(C) P- IV, Q- I, R-II, S-III

(D) P- II, Q- I, R-IV, S-III

Group-2

I) Sulfur mining

II) Soda ash production

III) Acetylene production

IV) Pulp Production

(GATE 2019)

Ans:- (B) P- III, Q- IV, R-II, S-I

Manufacture acetylene from paraffin hydrocarbons by pyrolysis (Wulff process):-

In the Wulff process acetylene is produced by thermal decomposition of hydrocarbons such as methane, ethane, propane, butane, ethylene etc. as per the following reactions.



Pyrolysis is carried out in the Wulff regenerative furnace which is a rectangular steel box filled with refractory bricks checker work.

Sulfite Process:-

- The sulfite process, the older and less used of the two primary chemical pulping processes, cooks wood chips in sulfurous acid combined with limestone to produce calcium bisulfite.
- The combination of sulfurous acid and calcium bisulfite dissolves the lignin in the wood and liberates the cellulose fibers.
- Sulfite pulp is soft and flexible, is moderately strong, and is used to supplement mechanical pulps (most typically in newsprint).

Solvay Process:-

- The Solvay process or ammonia-soda process is the major industrial process for the production of sodium carbonate & sodium hydrogen carbonate.
- The ingredients for this process are readily available and inexpensive: salt brine (from inland sources or from the sea) and limestone (from mines).
- The Solvay process results in soda ash (Na_2CO_3) from brine (NaCl) and from limestone (CaCO_3).
- $2 \text{NaCl} + \text{CaCO}_3 \rightarrow \text{Na}_2\text{CO}_3 + \text{CaCl}_2$
- $\text{NaCl} + \text{CO}_2 + \text{NH}_3 + \text{H}_2\text{O} \rightarrow \text{NaHCO}_3 + \text{NH}_4\text{Cl}$

Frasch Process:-

- The Frasch process is a method to extract sulfur from underground deposits.
- It is the **only industrial method** of recovering **sulfur** from elemental deposits.
- Most of the world's sulfur was obtained this way until the late 20th century, when sulfur recovered from petroleum and gas sources became more common place (Claus process).
- In the Frasch process, superheated water is pumped into the sulfur deposit; the sulfur melts and is extracted. The Frasch process is able to produce high-purity sulfur.

Use Code: DEVENDRAPOONIA to get 10% off on Plus Subscription

Claus Process (*sulfur recovery unit (SRU)*):-

- The Claus process is the most significant gas desulfurizing process, recovering elemental sulfur from gaseous hydrogen sulfide.
- Hydrogen sulfide produced in the hydro-desulfurization of refinery naphthas and other petroleum oils, is converted to sulfur in Claus plants.
- The reaction consists in two steps:

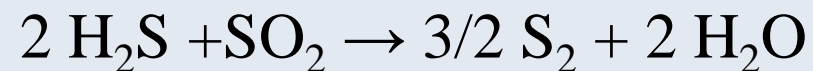
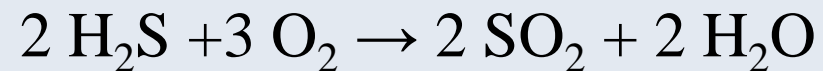

Q(11). In connection with petroleum refining, identify the incorrect statement among the following options.

- (A) Desalting of crude oil is done before processing it in atmospheric distillation unit
- (B) A stream of hydrogen is produced in catalytic reforming of naphtha
- (C) Asphalt used for paving is a petroleum product
- (D) Cetane number indicates the quality of petrol / motor spirit

(GATE 2018)

Ans:- (D) Cetane number indicates the quality of petrol / motor spirit

Cetane number (cetane rating) is an indicator of the combustion speed of diesel fuel and compression needed for ignition.

It plays a similar role for diesel as octane rating does for gasoline.

The CN is an important factor in determining the quality of diesel fuel, but not the only one; other measurements of diesel fuel's quality include (but are not limited to) energy content, density, lubricity, cold-flow properties and sulphur content.

Cetane number (or CN) is an inverse function of a fuel's ignition delay, the time period between the start of ignition and the first identifiable pressure increase during combustion of the fuel.

In a particular diesel engine, higher cetane fuels will have shorter ignition delay periods than lower Cetane fuels.

Cetane numbers are only used for the relatively light distillate diesel oils

Use Code: DEVENDRAPOONIA to get 10% off on Plus Subscription

Desalting of Crude Oil:-

- Any crude oil to be shipped by pipeline, or by any other form of transportation, must meet strict regulations in regard to water and salt content.
- Desalting is a water-washing operation performed initially at the production field and thereafter at the refinery site for additional crude oil cleanup, where the salt and water content specifications are even more rigid because of their negative effect in the downstream processes due to scale formation, corrosion, and catalyst deactivation.
- Desalting involves mixing heated crude oil with washing water, using a mixing valve or static mixers to ensure a proper contact between the crude oil and the water, and then passing it to a separating vessel, where a proper separation between the aqueous and organic phases is achieved.

Use Code: DEVENDRAPOONIA to get 10% off on Plus Subscription

Steam Reforming:-

- Steam reforming is the most widespread process for the generation of hydrogen-rich synthesis gas from light hydrocarbons.
- The feed materials natural gas, liquid gas or naphtha are endothermically converted with water steam into synthesis gas in catalytic tube reactors.

Asphalt:-

- Asphalt, also known as bitumen is a sticky, black, and highly viscous liquid or semi-solid form of petroleum.
- It may be found in natural deposits or may be a refined product, and is classed as a pitch. Before the 20th century, the term asphaltum was also used.

Q(12). Polyvinyl chloride is produced by

(A) co-polymerization

(B) addition-type kinetics

(C) reacting chlorine with polyethylene

(D) reacting hydrochloric acid with polyethylene

(GATE 2018)

Ans:- (B) addition-type kinetics

PVC:-

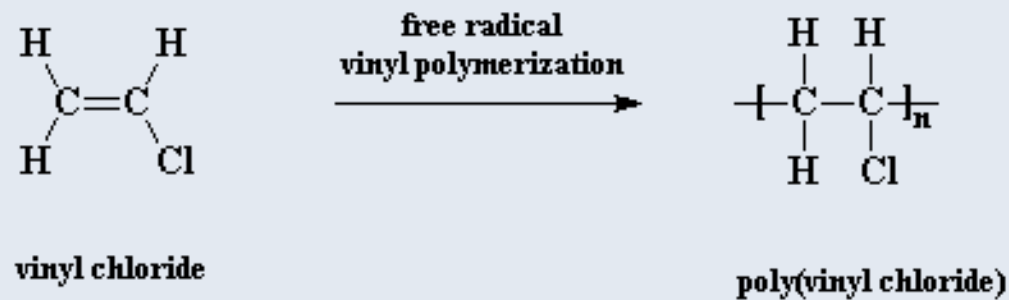

S.No	Addition Polymerization	Condensation polymerization
1.	Monomer must have at least a double bond or triple bond	Monomer must have at least two similar or different functional group
2.	Has no by product	Produces by products such as water, ammonia, HCl
3.	Addition of monomer results in a polymer	Monomers condensed to give a polymer
4.	Produces thermoplastics	Produces thermosets
5.	Results in homochain polymers	Results in hetero-chain polymers
6.	Examples:-polyvinyl chloride (PVC), polyethylene, polypropylene, poly tetrafluoroethen or TEFLON, etc.	Examples:- Bakelite, nylon, polyester(PET) etc.

Use Code: DEVENDRAPOONIA to get 10% off on Plus Subscription

Q(13). The molecular formula of the predominant chemical compound in commercial sugar is

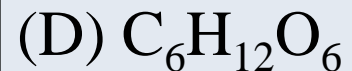
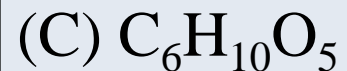
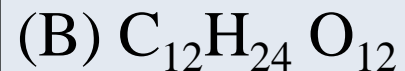
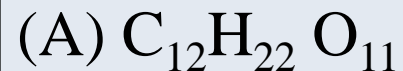

(GATE 2018)

Ans:- (A) $C_{12}H_{22}O_{11}$

- Sucrose is common sugar. It is a disaccharide, a molecule composed of two monosaccharides: glucose and fructose. Sucrose is produced naturally in plants, from which table sugar is refined. It has the molecular formula $C_{12}H_{22}O_{11}$.
- **Glucose and fructose** are monosaccharides and are the building blocks of **sucrose**, a disaccharide.

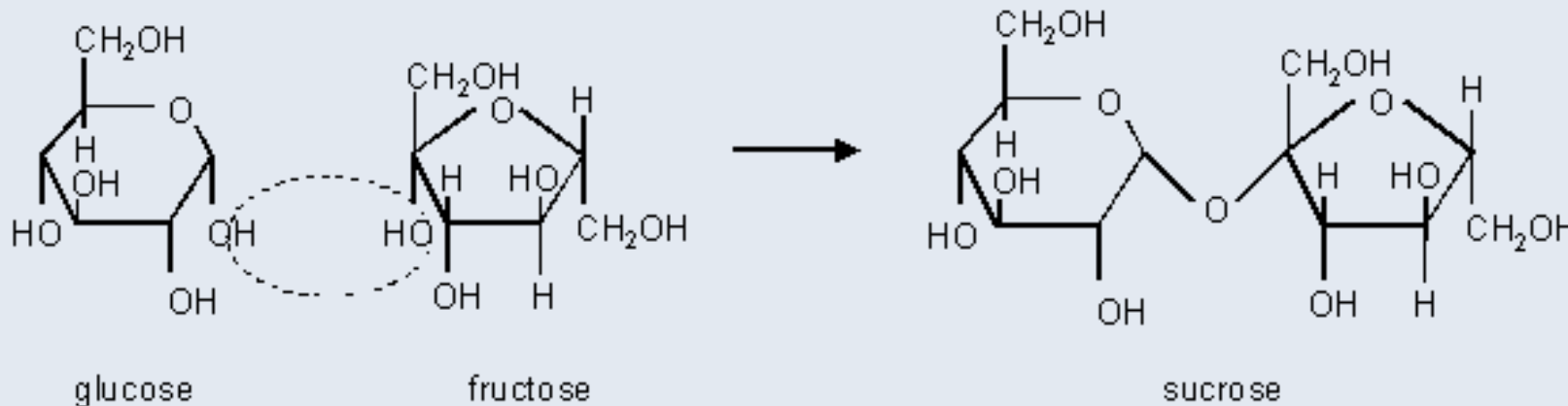

Q(14). Choose the correct statement

In viscose rayon manufacturing process,

- (A) carbon disulphide used as reactant for xanthate formation is regenerated in a later step
- (B) caustic soda used as reactant for steeping of cellulose is regenerated in a later step
- (C) Sulphuric acid is used in steeping process of cellulose
- (D) The spun viscous rayon is hardened in an alkali bath

(GATE 2018)

Ans:- (A) carbon disulphide used as reactant for xanthate formation is regenerated in a later step

viscose rayon is a fiber of regenerated cellulose.

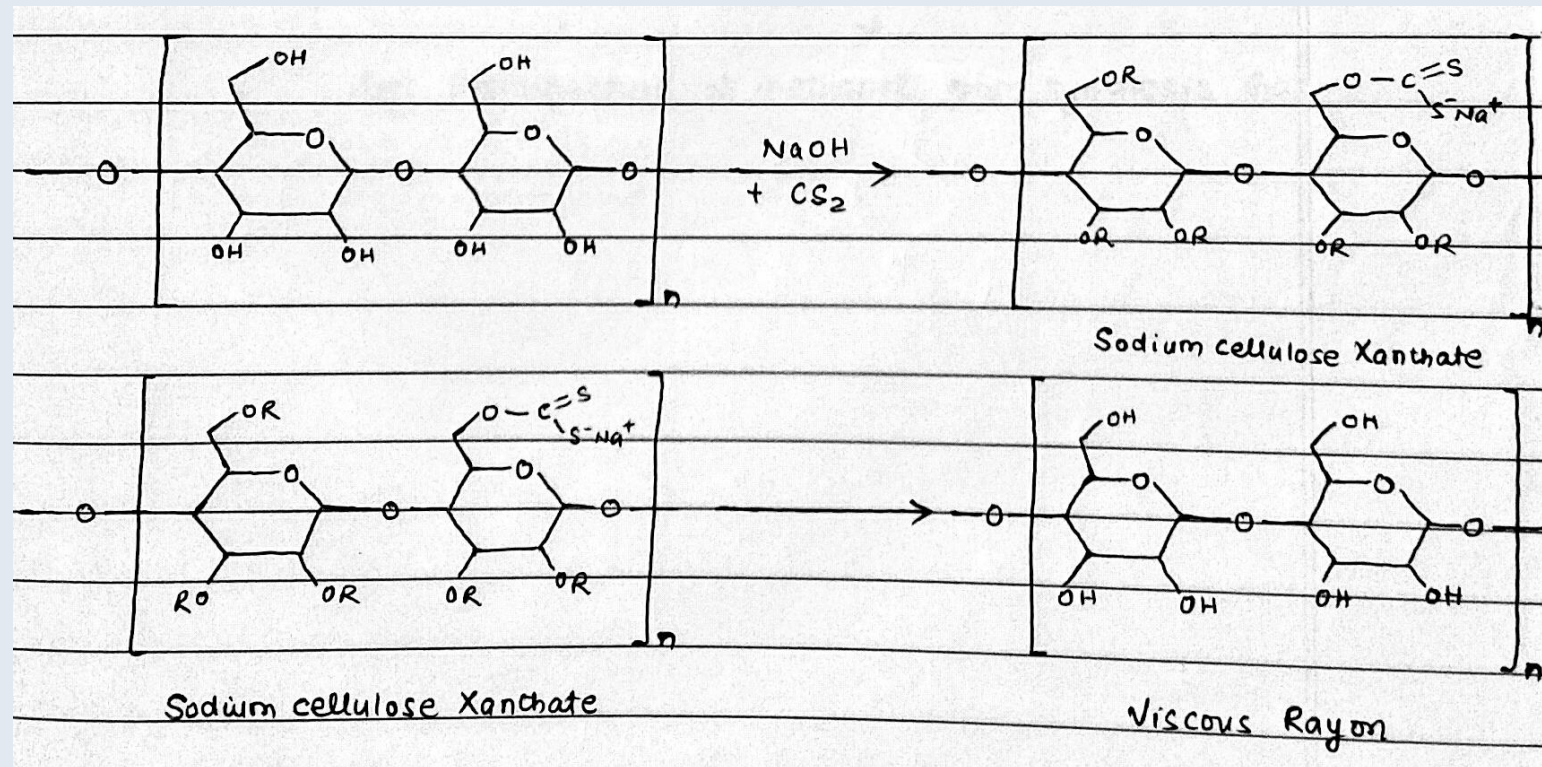
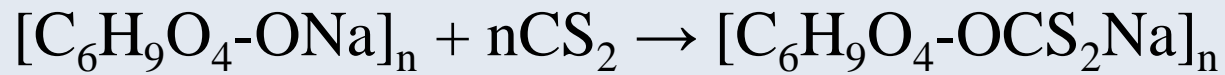

- Cellulose is a linear polymer of β -D-glucose units with the empirical formula $(C_6H_{10}O_5)_n$.
- To prepare viscose, dissolving pulp is treated with aqueous sodium hydroxide to form "alkali cellulose", which has the approximate formula $[C_6H_9O_4-ONa]_n$. The alkali cellulose is then treated with carbon disulfide to form sodium cellulose xanthate.
- $[C_6H_9O_4-ONa]_n + nCS_2 \rightarrow [C_6H_9O_4-OCS_2Na]_n$
- The xanthate groups are hydrolyzed to regenerate cellulose and release dithiocarbonic acid that later decomposes to carbon disulfide and water.
- $[C_6H_9O_4-OCS_2Na]_{2n} + nH_2SO_4 \rightarrow [C_6H_9O_4-OH]_{2n} + 2nCS_2 + nNa_2SO_4$
- $H_2COS_2 \rightarrow H_2O + CS_2$
- Aside from regenerated cellulose, acidification gives hydrogen sulfide (H_2S), sulfur, and carbon disulfide

Q(15). The DCDA (Double Contact Double Absorption) process is used for the manufacture of

(A) Urea

(B) sulfuric acid

(C) nitric acid

(D) ammonia

(GATE 2017)

Use Code: DEVENDRAPOONIA to get 10% off on Plus Subscription

Ans :- (B) sulfuric acid

Explanation:-

Contact Process -

- Currently high concentrated sulphuric acid is produced.
- Vanadiumpentaoxide (V_2O_5) or Pt used as catalyst.
- More economical than lead chamber process.
- Can also produce SO_3 and oleum.

DCDA Process –

- Next steps to the Contact Process.
- SO_2 & SO_3 passed through absorption towers twice for further absorption & conversion of SO_2 to SO_3 & production of higher grade sulphuric acid.

Use Code: DEVENDRAPOONIA to get 10% off on Plus Subscription

Contact Process:-

1	Production of SO ₂ from Sulphur	$S + O_2 \longrightarrow SO_2$
2	Purification of sulphuric dioxide	To remove dust particle, oxides of iron & arsenic
3	Catalytic oxidation of SO ₂ to SO ₃	$2SO_2 + O_2 \longrightarrow 2SO_3 + \text{heat}$
4	Conversion of SO ₃ to oleum	$SO_3 + H_2SO_4 \longrightarrow H_2S_2O_7$
5	Dilution of oleum to sulphuric acid	$H_2S_2O_7 + H_2O \longrightarrow 2H_2SO_4$

Q(16). Match the polymerization processes in Group-1 with the polymers in Group-2

Group – 1

- P) Free radical polymerization
- Q) Ziegler Natta polymerization
- R) Condensation polymerization

Group – 2

- I) Nylon 6.6
- II) Polypropylene
- III) Poly vinyl chloride

Choose the correct set of combinations.

- (A) P-I, Q-II, R-III
- (C) P-I, Q-III, R-II

- (B) P-III, Q-II, R-I
- (D) P-II, Q-I, R-III

(GATE 2017)

Ans :- (B) P-III, Q-II, R-I

Free radical polymerization:-

Examples- Polyethylene, PVC, Polystyrene etc.

Ziegler Natta polymerization:-

Ziegler-Natta catalyst- TiCl_3 and $\text{Al}(\text{C}_2\text{H}_5)_2\text{Cl}$, or TiCl_4 with $\text{Al}(\text{C}_2\text{H}_5)_3$

Examples:- Polyethylene, Polypropylene etc.

Condensation polymerization:-

Losing small molecules as byproducts

Step growth polymerization

Examples:- Nylon 6,6 , PET etc.

Use Code: DEVENDRAPOONIA to get 10% off on Plus Subscription

Q(17). The purpose of methanation reaction used in ammonia plants is to

- (A) remove CO as it is a catalyst poison
- (B) increase the amount of hydrogen
- (C) remove sulfur as it is a catalyst poison
- (D) utilize methane as a catalyst for ammonia synthesis

(GATE 2017)

Ans :- (A) remove CO as it is a catalyst poison

Methanation Reaction:-

➤ Methanation is the reaction by which carbon oxides and hydrogen are converted to methane and water.

➤ **Reactions:-**



➤ **Catalyst-** Nickel

➤ In industry, there are two main uses for methanation:-

(1) to purify synthesis gas (i.e. remove traces of carbon oxides)

(2) to manufacture methane

Q(18).Match the equipment in Group-1 with the process in Group-2

Group – 1

Group – 2

P) Fluidized bed

I) Paper – making

Q) Multistage adiabatic reactor with
Inter-state cooling.

II) Sodium hydroxide manufacture.

R) Fourdrinier machine

III) SO₂ oxidation.

S) Diaphragm cell

IV) Catalytic cracking.

Choose the correct set of combinations.

(A) P-IV, Q-III, R-I, S-II

(B) P-IV, Q-III, R-II, S-I

(C) P-III, Q-IV, R-I, S-II

(D) P-III, Q-IV, R-II, S-I

(GATE 2017)

Ans :- (A) P-IV, Q-III, R-I, S-II

Catalytic Cracking:-

- Upgradation of residue.
- Catalytic cracking cracks low value high molecular weight hydrocarbons to more value added products (low molecular weight) like gasoline, LPG Diesel etc.

Catalytic oxidation of SO_2 to SO_3 :-

- Catalyst - vanadium pentoxide (V_2O_5)
- This process is strongly exothermic.

Fourdrinier machine:-

- Many modern papermaking machines are based on the principles of the Fourdrinier Machine.

Cells which are used for production of caustic soda are:-

1. Diaphragm cell
2. Mercury cathode cell
3. Membrane cell

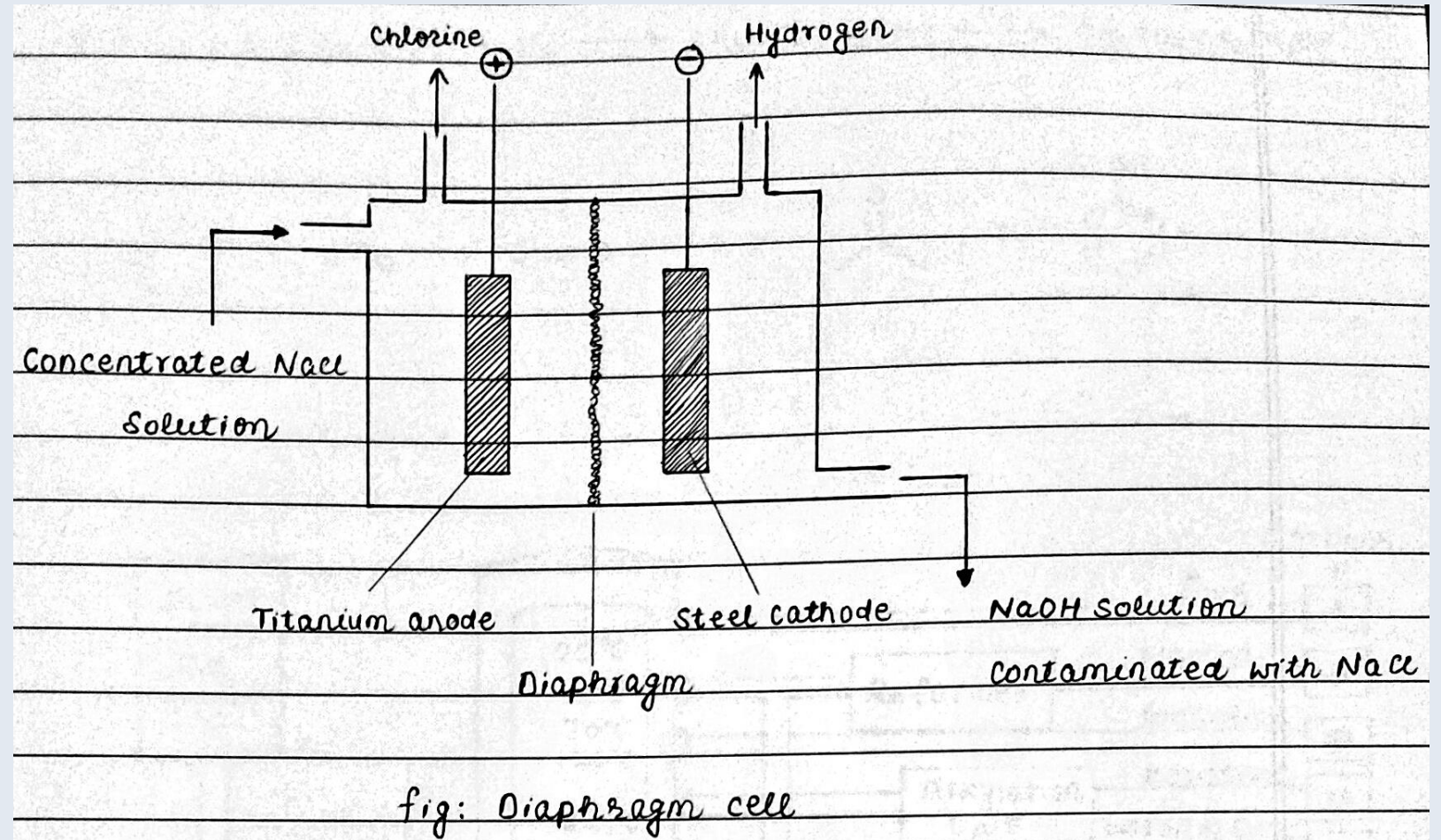

Q(19). Two paper pulp plants P and Q use the same quality of bamboo as a raw material. The chemicals used in their digester are as follows :

	Plant P	Plant Q
NaOH	Yes	No
Na ₂ S	Yes	No
Na ₂ CO ₃	Yes	Yes
NaHCO ₃	No	Yes
Na ₂ SO ₃	No	Yes

Which one of the following statements is CORRECT ?

- (A) Plant P and Plant Q both use the Sulfite process
- (B) Plant P and Plant Q both use the Kraft process
- (C) Plant P uses Sulfite process
- (D) Plant P uses Kraft process

Ans :- (D) Plant P uses Kraft process

Kraft Process:-

- The kraft process (also known as kraft pulping or sulfate process).
- It is a process for conversion of wood into wood pulp.
- The Kraft pulping involves pulping, washing, screening and bleaching.
- Bleaching chemicals- NaOH , Na_2S , Na_2CO_3 , Cl_2 , NaClO , ClO_2 , O_3 , H_2O_2 , $\text{Na}_2\text{S}_2\text{O}_4$

Sulfite process:-

- Earlier use for pulping, but now replaced with Kraft pulping.
- Acid Sulfite - $\text{NaHSO}_3 + \text{SO}_2$
- Bisulfate - NaHSO_3
- Neutral Sulfite: $\text{Na}_2\text{SO}_3 + \text{Na}_2\text{SO}_3$

Use Code: DEVENDRAPOONIA to get 10% off on Plus Subscription

Q(20). Match the industrial Process in Group-1 with the catalyst materials in Group-2.

Group-1		Group-2	
(P)	Ethylene polymerization	I)	Nickel
(Q)	Petroleum feedstock cracking	II)	Vanadium pentoxide
(R)	Oxidation of SO_2 to SO_3	III)	Zeolite
(S)	Hydrogenation of oil	(IV)	Aluminium triethyl with Titanium chloride promoter

Choose the correct set of combinations.

(A) P-IV, Q-III, R-II, S-I

(B) P-I, Q-IV, R-III, S-II

(C) P-I, Q-II, R-III, S-IV

(D) P-II, Q-III, R-IV, S-I

(GATE 2016)

Use Code: DEVENDRAPOONIA to get 10% off on Plus Subscription

Ans :- (A) P-IV, Q-III, R-II, S-I

Ethylene polymerization:-

- Ziegler-Natta catalyst- TiCl_3 and $\text{Al}(\text{C}_2\text{H}_5)_2\text{Cl}$, or TiCl_4 with $\text{Al}(\text{C}_2\text{H}_5)_3$ used
- Another example - Propylene polymerization

Petroleum feed stock cracking:-

- Upgradation of residue.
- Catalytic cracking cracks low value high molecular weight hydrocarbons to more value added products (low molecular weight) like gasoline, LPG Diesel etc.
- Catalyst - Zeolite or Pt

Catalytic oxidation of SO_2 to SO_3 :-

- Catalyst - vanadium pentoxide (V_2O_5)
- This process is strongly exothermic.

Hydrogenation of oil:-

- Unsaturated fats can be made into saturated fats.
- The double bonds are converted to single bonds in the reaction.
- A nickel catalyst is used to speed up the reaction.

Q(21). Match the polymer mentioned on the left with the catalyst used for its manufacture given on the right.

(I) Low density Polyethylene

(P) Ziegler-Natta catalyst

(II) High density Polyethylene

(Q) Traces of Oxygen

(III) Polyethylene Terephthalate

(R) Butyl Lithium

(IV) Polyvinyl Chloride

(S) Antimony

Choose the correct set of combinations.

(A) I-Q, II-R, III-S, IV-P

(B) I-S, II-P, III-Q, IV-R

(C) I-Q, II-P, III-S, IV-R

(D) I-S, II-R, III-P, IV-Q

(GATE 2016)

Use Code: DEVENDRAPOONIA to get 10% off on Plus Subscription

Ans :- (C) I-Q, II-P, III-S, IV-R

Low density Polyethylene:-

- Catalyst - Traces of oxygen.
- Density range of 0.910–0.940 g/cm³.
- High pressure process.
- free radical polymerization.

High density Polyethylene:-

- Catalyst - Ziegler-Natta catalyst (TiCl₃ and Al(C₂H₅)₂Cl, or TiCl₄ with Al(C₂H₅)₃ used)
- Large strength-to-density ratio
- Density range from 0.93 to 0.97 g/cm³

Polyethylene Terephthalate:-

- Also known as - PET, PETE, Dacron, Terylene
- Catalyst - Antimony
- Monomer- (i) Dimethyl terephthalate process - dimethyl terephthalate, ethylene glycol
(ii) Terephthalic acid process - terephthalic acid, ethylene glycol

Polyvinyl Chloride:-

- Catalyst - Butyl Lithium
- Free radical polymerization

Q(22). Match the technologies in Group 1 with the entries in Group 2

Group 1

(P) Urea manufacture

(Q) Coal gasification

(R) Controlled release of chemicals

(S) Deep hydrodesulphurization

Group 2

I) Microencapsulation

II) Ultra-low Sulphur diesel

III) Shale oil

IV) Prilling tower

V) Gas hydrates

VI) Gas-solid non-catalytic reaction

Choose the correct set of combinations.

(A) P-I, Q-V, R-II, S-VI

(B) P-IV, Q-VI, R-I, S-II

(C) P-IV, Q-I, R-III, S-II

(D) P-V, Q-VI, R-IV, S-II

(GATE 2016)

Use Code: DEVENDRAPOONIA to get 10% off on Plus Subscription

Ans :- (B) P-IV, Q-VI, R-I, S-II

Urea manufacture -

- Prilling tower used to convert fertilizer into the granular form.

Coal gasification -

- Coal gasification is the process of producing syngas—a mixture consisting primarily of carbon monoxide (CO), hydrogen (H₂), carbon dioxide (CO₂), methane (CH₄), and water vapor (H₂O)—from coal and water, air and/or oxygen
- Gas-solid non-catalytic reaction

Controlled release of chemicals –

- Microencapsulation

Deep hydrodesulphurization -

- Ultra-low Sulphur diesel

Urea:-

Raw Materials:-

- (i) Ammonia can be synthesized by Haber – Bosch
- (ii) Carbon dioxide from synthesis gas

Reactions:-

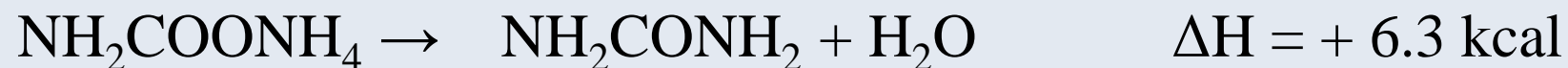
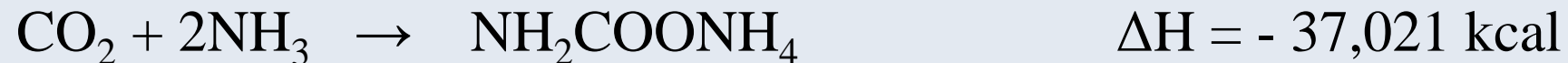

Q(23).Match the chemicals written on the left with the raw materials required to produce them mentioned on the right

- | | |
|----------------------------------|---|
| (I) Single Superphosphate (SSP) | (P) Rock phosphate + Sulfuric Acid+ Ammonia |
| (II) Triple Superphosphate (TSP) | (Q) Brine |
| (III) Diamonium Phosphate (DAP) | (R) Rock phosphate + Sulfuric Acid |
| (IV) Caustic soda | (S) Rock phosphate + Phosphoric Acid |

Choose the correct set of combinations.

- | | |
|----------------------------|----------------------------|
| (A) I-Q, II-R, III-S, IV-P | (B) I-S, II-P, III-Q, IV-R |
| (C) I-R, II-S, III-P, IV-Q | (D) I-S, II-R, III-P, IV-Q |

(GATE 2015)

Use Code: DEVENDRAPOONIA to get 10% off on Plus Subscription

Ans :- (C) I-R, II-S, III-P, IV-Q

Single Superphosphate (SSP) –

[Rock phosphate + Sulfuric Acid]

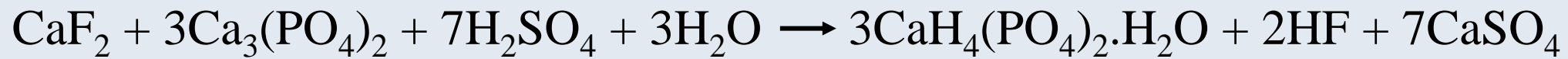

Triple Superphosphate (TSP) –

[Rock phosphate + Phosphoric Acid]



Diamonium Phosphate (DAP) –

[Rock phosphate + Sulfuric Acid + Ammonia]

Caustic soda (NaOH) -

Brine

Q(24). Select the WRONG statement regarding water gas shift converters from the list below :

- (A) Inter-stage cooling is provided between the two stages of shift converters
- (B) Usually high temperature shift (HTS) reactor has a iron-based catalyst and low temperature shift (LTS) reactor has a copper-based catalyst
- (C) HTS reactor is followed by LTS reactor
- (D) LTS reactor is followed by HTS reactor

(GATE 2015)

Ans :- (D) LTS reactor is followed by HTS reactor.

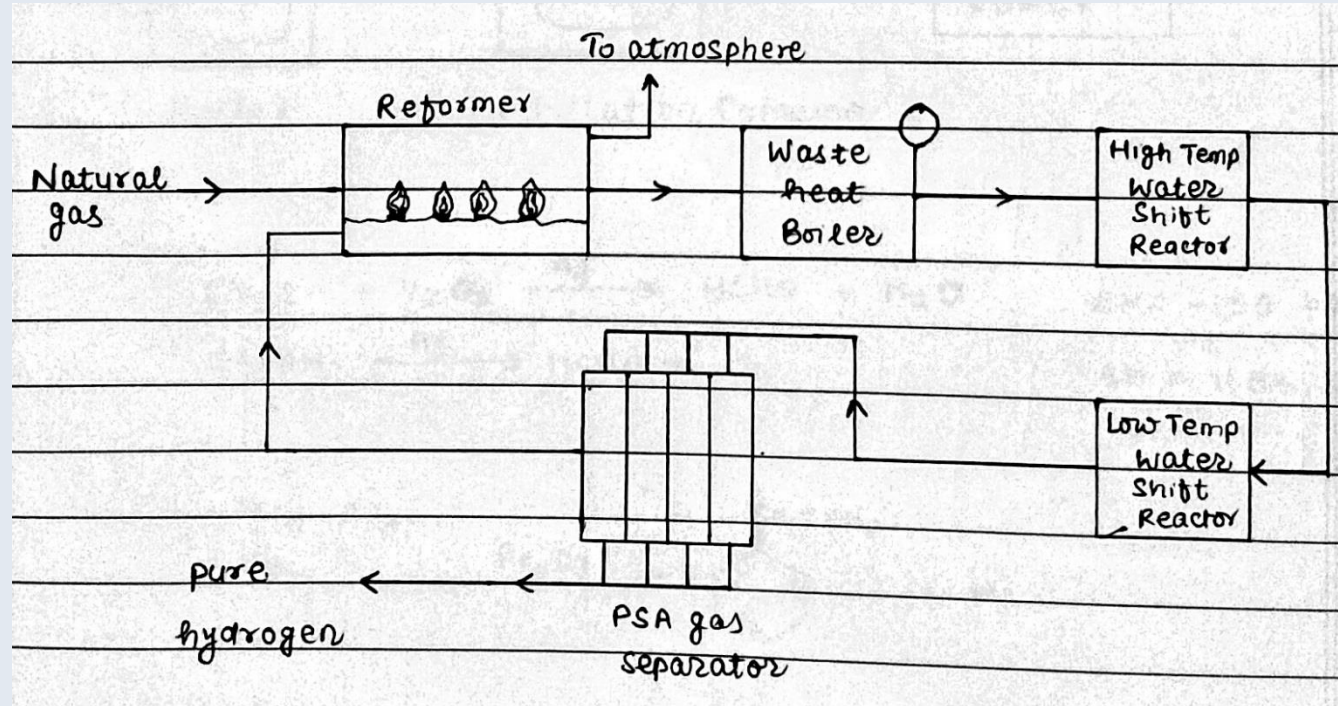

- The **water-gas shift reaction** (WGSR) describes the reaction of CO & water vapor to form CO_2 & H_2 .
- $\text{CO} + \text{H}_2\text{O} \rightleftharpoons \text{CO}_2 + \text{H}_2$
- Mixture of CO & H_2 known as water gas.

Use Code: **DEVENDRAPOONIA** to get 10% off on Plus Subscription

Q(25). Decomposition efficiency (η_D) of an electrolytic cell used for producing NaOH is defined as

(A) $\eta_D = (\text{grams of NaOH produced} / \text{grams of NaCl decomposed}) \times 100$

(B) $\eta_D = (\text{grams of NaOH produced} / \text{grams of NaCl charged}) \times 100$

(C) $\eta_D = (\text{gram equivalents of NaOH produced} / \text{gram equivalents of NaCl charged}) \times 100$

(D) $\eta_D = (\text{theoretical current to produce one gram equivalent} / \text{actual current to produce one gram equivalent}) \times 100$

(GATE 2014)

Ans:- (C) $\eta_D = (\text{gram equivalents of NaOH produced} / \text{gram equivalents of NaCl charged}) \times 100$

Use Code: DEVENDRAPOONIA to get 10% off on Plus Subscription

Q(26). Catalytic cracking is

- (A) a hydrogen addition process
- (B) a carbon rejection process
- (C) an exothermic process
- (D) a coking process

(GATE 2014)

Ans:- (B) A carbon rejection process

S.N	Catalytic Cracking	Hydro-cracking
O.		
1.	Carbon rejection	Hydrogen addition
2.	Riser-regenerator-configuration	Down flow packed bed
3.	LPG/gasoline	Kerosene/diesel
4.	Product rich in unsaturated components	Few aromatics, low S- and N-content in product

Use Code: DEVENDRAPOONIA to get 10% off on Plus Subscription

Q(27). Which ONE of the following statements is CORRECT?

- (A) The major components of biodiesel are triglycerides
- (B) Biodiesel is essentially a mixture of ethyl esters
- (C) Biodiesel is highly aromatic
- (D) Biodiesel has a very low aniline point

(GATE 2014)

Ans:- (B) Biodiesel is essentially a mixture of ethyl esters

- Biodiesel refers to a vegetable oil- or animal fat-based diesel fuel consisting of long-chain alkyl (methyl, ethyl, or propyl) esters.
- Biodiesel is an alternative fuel similar to conventional or 'fossil' diesel.
- Biodiesel can be produced from straight vegetable oil, animal oil/fats, tallow and waste cooking oil.
- The process used to convert these oils to Biodiesel is called transesterification.
- Biodiesel has many environmentally beneficial properties.

Use Code: DEVENDRAPOONIA to get 10% off on Plus Subscription

Q(28). Match the raw materials of Groups 1 and 2 with the final products of Group 3

Group 1	Group 2	Group 3
P ₁ : Ethylene	Q ₁ : Ammonia	R ₁ : Synthetic fibre
P ₂ : Propylene	Q ₂ : 1- Butene	R ₂ : Nylon 6,6
P ₃ : Adipic Acid	Q ₃ : Ethylene Glycol	R ₃ : LLDPE
P ₄ : Terephthalic Acid	Q ₄ : Hexamethylene diamine	R ₄ : Acrylonitrile

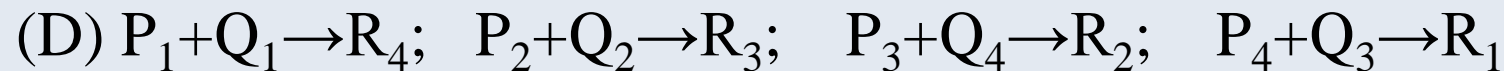
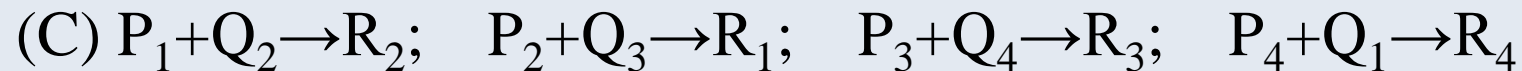
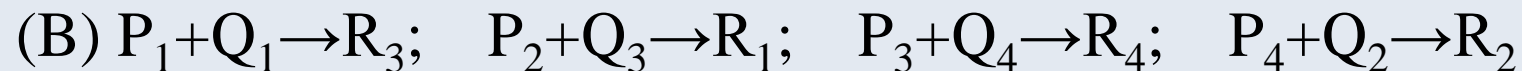
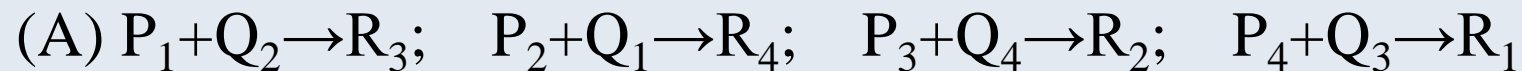

(GATE 2014)

Ans:- (A) $P_1+Q_2\rightarrow R_3$; $P_2+Q_1\rightarrow R_4$; $P_3+Q_4\rightarrow R_2$; $P_4+Q_3\rightarrow R_1$

S.No.	Polymer	Monomers
1.	LLDPE	Ethylene+1- Butene
2.	Acrylonitrile	Propylene+ Ammonia
3.	Nylon 6,6	Adipic Acid + Hexamethylene diamine
4.	Sythetic fibre(PET)	Terephthalic Acid + Ethylene Glycol

Use Code: DEVENDRAPOONIA to get 10% off on Plus Subscription

Q(29). In the manufacture of sulphuric acid by the contact process, the catalytic oxidation of SO_2 is carried out in multiple stages mainly to

- (A) increase the reaction rate by providing inter-stage heating
- (B) increase the overall conversion by providing inter-stage heating
- (C) increase the overall conversion by providing inter-stage cooling
- (D) decrease the overall conversion by removing sulphur trioxide between stages (GATE 2013)

Ans:- (C) increase the overall conversion by providing inter-stage cooling

Catalytic oxidation of SO₂ to SO₃:-

- Catalyst - vanadium pentoxide (V₂O₅)
- This process is strongly exothermic.
- Better temperature control leads to better conversion.

Q(30). Match the reactant-product combination in Group 1 with the unit process in Group 2.

Group 1

(P) propylene – butanol

(Q) cumene – phenol

(R) butane – butadiene

(S) ethylene dichloride – vinyl chloride

Group 2

(1) Pyrolysis

(2) Dehydrogenation

(3) Hydroformylation

(4) Peroxidation

Choose the correct set of combinations.

(A) P-3, Q-2, R-4, S-1

(B) P-2, Q-4, R-3, S-1

(C) P-1, Q-3, R-2, S-4

(D) P-3, Q-4, R-2, S-1

(GATE 2013)

Use Code: DEVENDRAPOONIA to get 10% off on Plus Subscription

Ans:- (D) P-3, Q-4, R-2, S-1

Propylene to Butanol (Oxo process):- Hydro formylation

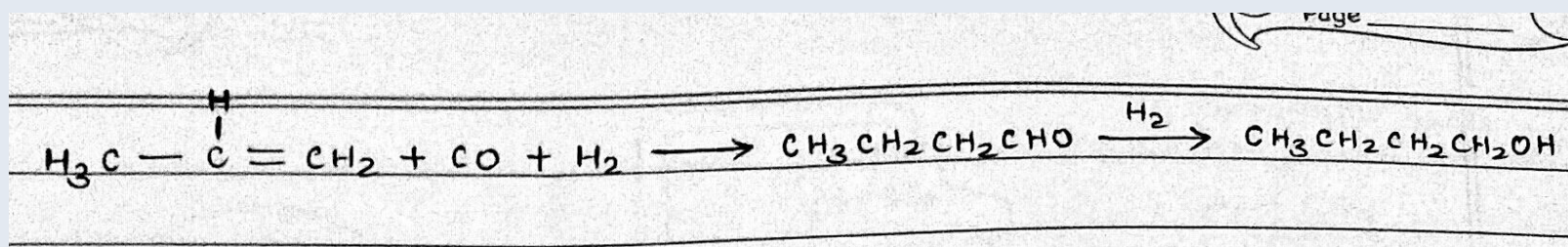

Cumene to phenol:- Peroxidation

Peroxidation: Cumene + Air \rightarrow Cumene Hydroperoxide.

Hydrolysis: Cumene Hydroperoxide + $\text{H}_2\text{SO}_4 \rightarrow$ Phenol + Acetone.

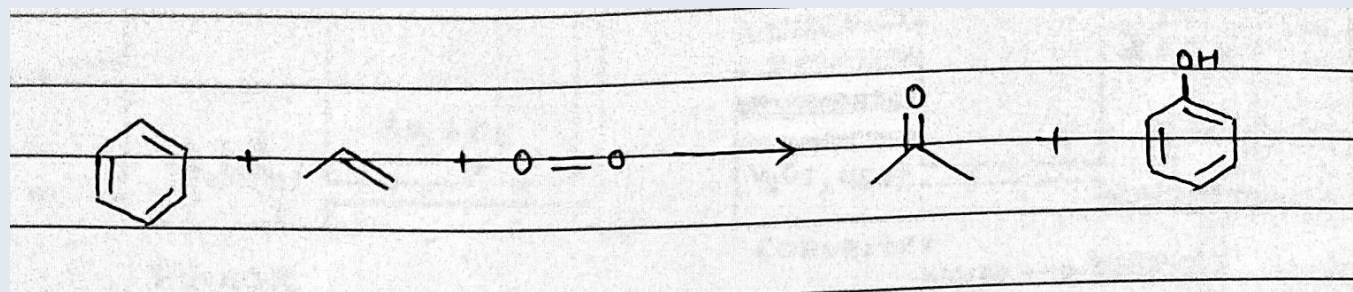

butane to butadiene:- Dehydrogenation

- 1,3-Butadiene can also be produced by catalytic dehydrogenation of normal butenes.
- It is an important industrial chemical used as a monomer in the production of synthetic rubber.
- The molecule can be viewed as two vinyl groups ($\text{CH}_2=\text{CH}_2$) joined together.
- structure $\text{H}_2\text{C}=\text{CH}-\text{CH}=\text{CH}_2$.

ethylene dichloride to vinyl chloride:- Pyrolysis

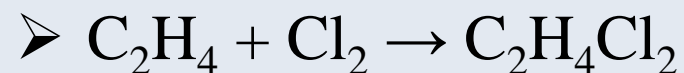

Vinyl chloride is produced in a two step process from ethylene.

- Ethylene first reacts with Chlorine to produce Ethylene dichloride.
- The purified Ethylene dichloride undergoes selective cracking to form vinyl chloride.

Use Code: DEVENDRAPOONIA to get 10% off on Plus Subscription

Q(31). Identify which of the following statements are FALSE.

(P) Oils with an oleic radical (1 double bond) are more suitable than oils with a linolenic radical (3 double bonds) as film forming vehicles for paints.

(Q) Production of synthesis gas from coal and steam is an endothermic process

(R) Use of chlorine for bleaching of wood pulp results in the release of dioxins

(S) In the manufacture of urea from ammonia, the main intermediate product formed is ammonium bicarbonate

(A) P and Q only

(B) R and S only

(C) Q and R only

(D) P and S only

(GATE 2013)

Use Code: DEVENDRAPOONIA to get 10% off on Plus Subscription

Ans:- (D) P and S only

- Oils with an oleic radical (1 double bond) are less suitable than oils with a linolenic radical (3 double bonds) as film forming vehicles for paints.
- In the manufacture of urea from ammonia, the main intermediate product formed is ammonium carbamate.

Use Code: DEVENDRAPOONIA to get 10% off on Plus Subscription

Q(32). In petroleum refining, catalytic reforming is used to convert

- (A) Paraffins and naphthenes to aromatics
- (B) Paraffins to hydrogen and carbon monoxide
- (C) Gas oil to diesel and gasoline
- (D) Light olefins to gasoline

(GATE 2012)

Use Code: DEVENDRAPOONIA to get 10% off on Plus Subscription

Ans:- (A) Paraffins and naphthenes to aromatics

- The reforming process is a catalytic process which converts low octane naphthas into higher octane reformat products.
- Process re-arranges or re-structures the hydrocarbon molecules in the naphtha feedstocks as well as breaking some of the molecules into smaller molecules.
- Among the same carbon number compounds, the order of RONC is (Research Octane Number) Paraffins < Naphthenes < Aromatics.
- Branched paraffins also have high octane. It increases with degree of branching.

REACTIONS IN CATALYTIC REFORMING:-

Desirable

- Dehydrogenation of naphthenes to aromatics.
- Isomerisation of paraffins and naphthenes.
- Dehydrocyclisation of paraffins to aromatics.

Non-Desirable

- Hydrocracking of paraffins to lower molecular weight compounds.

Q(33). The final boiling points of gasoline, diesel, atmospheric gas oil (AGO) and lubricating oils vary as

- (A) gasoline > diesel > AGO > lubricating oils
- (B) lubricating oils > AGO > diesel > gasoline
- (C) AGO > lubricating oils > diesel > gasoline
- (D) lubricating oils > diesel > AGO > gasoline

(GATE 2012)

Ans:- (B) lubricating oils > AGO > diesel > gasoline

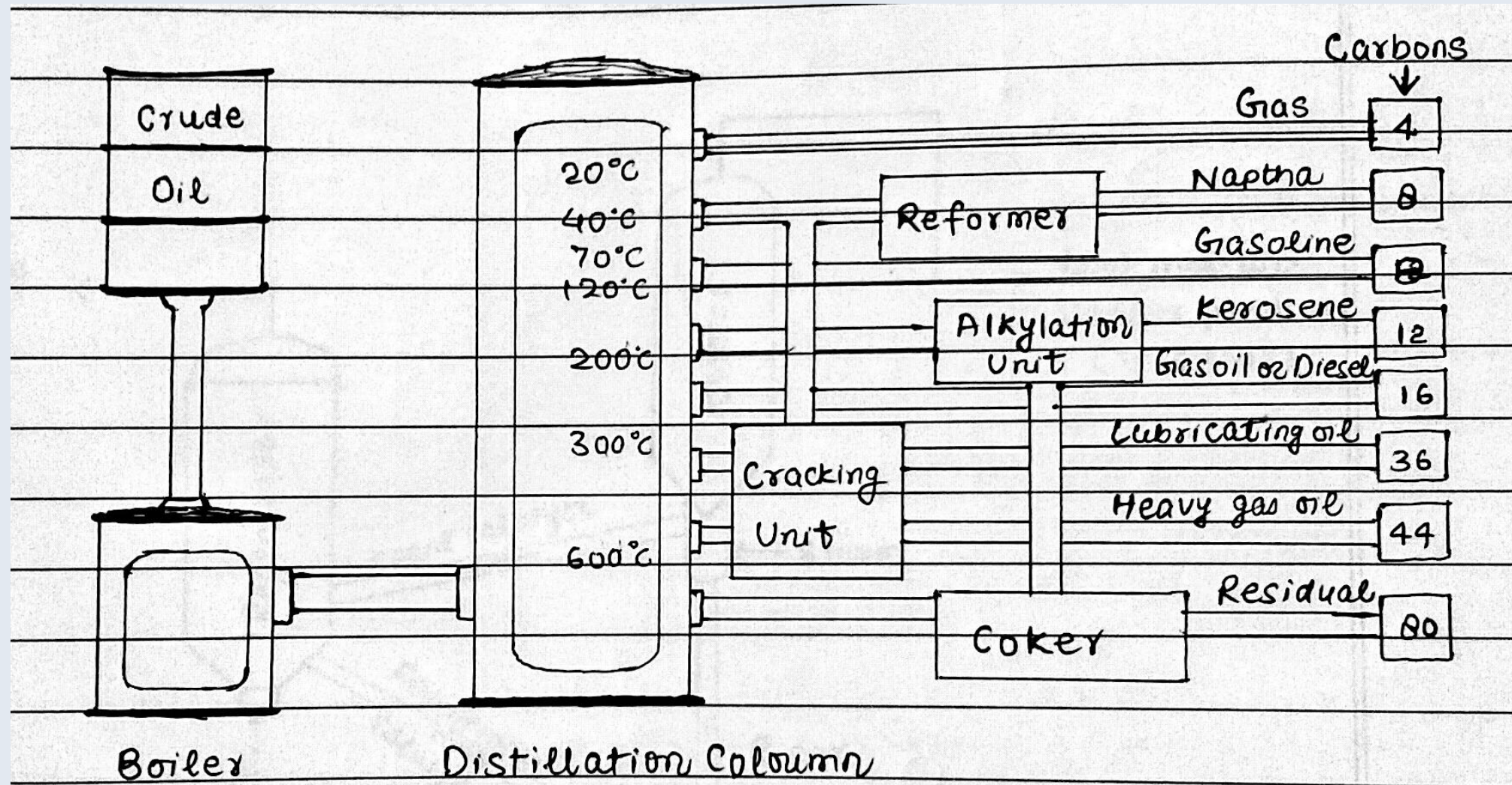

Q(34). The main unit processes used for the production of hydrogen from natural gas are steam reforming (SR), pressure swing adsorption (PSA), low temperature water gas shift reaction (LT WGS) and high temperature water gas shift reaction (HT WGS).

The correct sequence of these in the plant is

- (A) SR; LT WGS; HT WGS; PSA (B) PSA; SR; LT WGS; HT WGS
(C) SR; HT WGS; LT WGS; PSA (D) PSA; HT WGS; LT WGS; SR

(GATE 2012)

- **Steam reforming** is a method for producing hydrogen, carbon monoxide, or other useful products from hydrocarbon fuels such as natural gas.
- The steam methane reformer is widely used in industry to make hydrogen.

steam methane reforming (SMR):-

- It is the most common method of producing commercial bulk hydrogen at about 95% of the world production
- Hydrogen is used in the industrial synthesis of ammonia and other chemicals.
- At high temperatures (700 – 1100 °C) and in the presence of a metal-based catalyst (**nickel**), steam reacts with methane to yield carbon monoxide and hydrogen.
- $\text{CH}_4 + \text{H}_2\text{O} \rightleftharpoons \text{CO} + 3 \text{H}_2$

Use Code: DEVENDRAPOONIA to get 10% off on Plus Subscription

Ans:- (C) SR; HT WGS; LT WGS; PSA

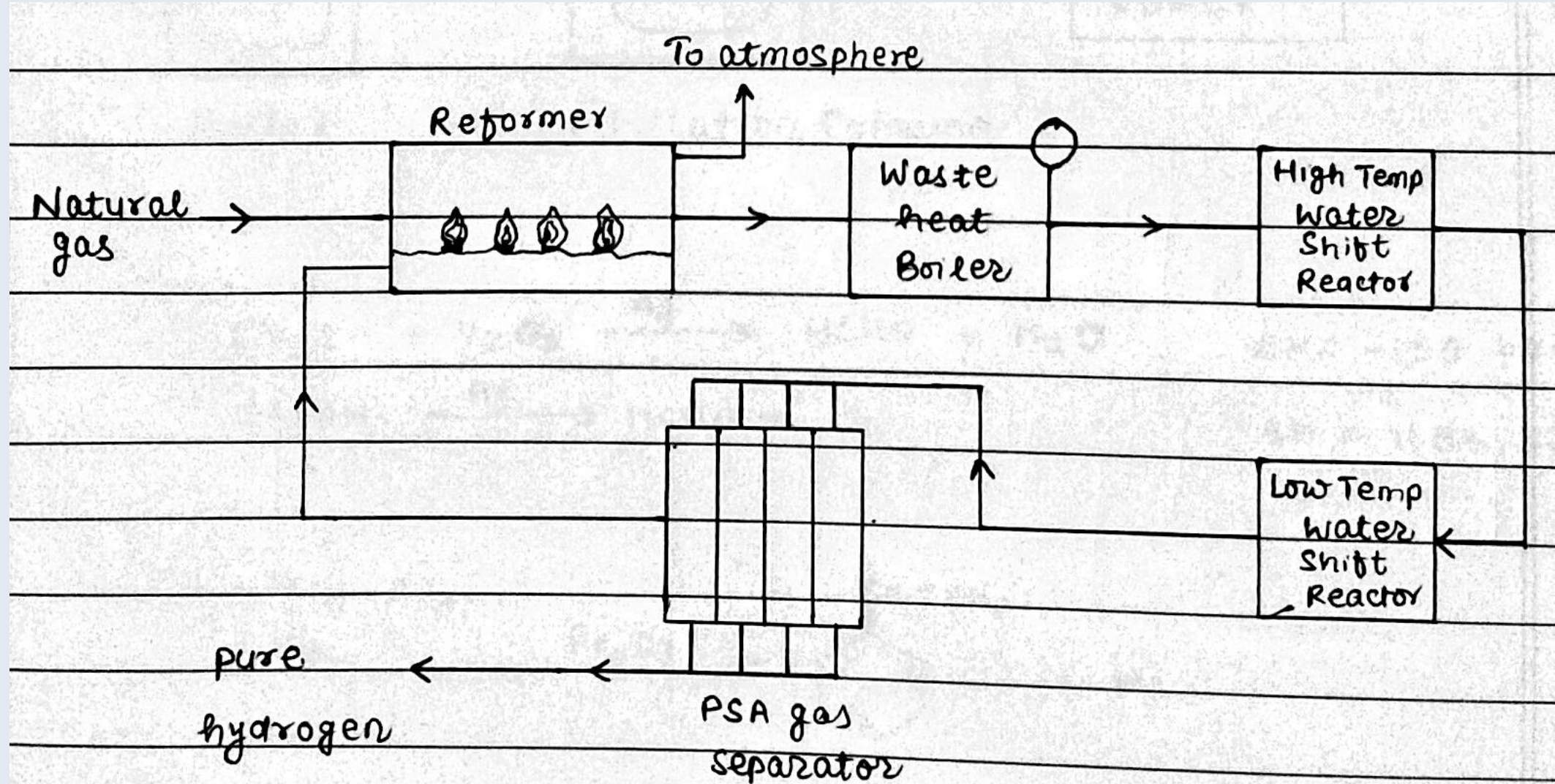

Use Code: DEVENDRAPOONIA to get 10% off on Plus Subscription

Water gas Shift Reaction:-

- The carbon monoxide gas can then be passed with steam over iron oxide or other oxides and undergo a water gas shift reaction to obtain further quantities of H₂
- In a second stage, additional hydrogen is generated through the lower-temperature, exothermic, water gas shift reaction, performed at about 360 °C:
- $\text{CO} + \text{H}_2\text{O} \rightarrow \text{CO}_2 + \text{H}_2$

Q(35). Match the process in Group I with the catalyst in Group II

Group I

P. Fischer-Tropsch synthesis

Q. Formaldehyde from methanol

R. Hydrogenation of vegetable oils

S. Dehydrogenation of ethylbenzene

Group II

I. Nickel

II. Fe_2O_3

III. Silver

IV. Cobalt

Choose the correct set of combinations.

(A) P-III, Q-IV, R-I, S-II

(B) P-IV, Q-II, R-I, S-III

(C) P-IV, Q-III, R-I, S-II

(D) P-III, Q-IV, R-II, S-I

(GATE 2012)

Use Code: DEVENDRAPOONIA to get 10% off on Plus Subscription

Ans:- (C) P-IV, Q-III, R-I, S-II

Fischer- Tropsch synthesis :-

- The Fischer- Tropsch process is a catalytic chemical reaction in which carbon monoxide (CO) and hydrogen (H₂) in the syngas are converted into hydrocarbons of various molecular weights according to the following equation:
- $(2n+1) \text{H}_2 + n \text{CO} \rightarrow \text{C}_n \text{H}_{(2n+2)} + n \text{H}_2\text{O}$
- Catalyst – Cobalt
- The main focus of FT process is the production of high molecular weight linear alkanes and diesel fuel.

Formaldehyde from methanol:-

- Formaldehyde is one of the most important chemical products for the production of urea-phenolic, acetal and melamine resins.
- industrial production is based on silver catalyst.

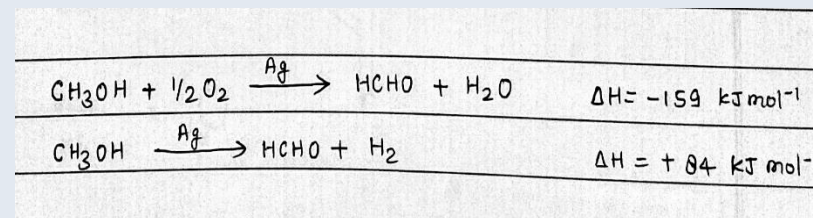

Hydrogenation of vegetable oils:-

- Unsaturated fats can be made into saturated fats.
- The double bonds are converted to single bonds in the reaction.
- A **raney nickel** catalyst is used to speed up the reaction.

Dehydrogenation of ethylbenzene:-

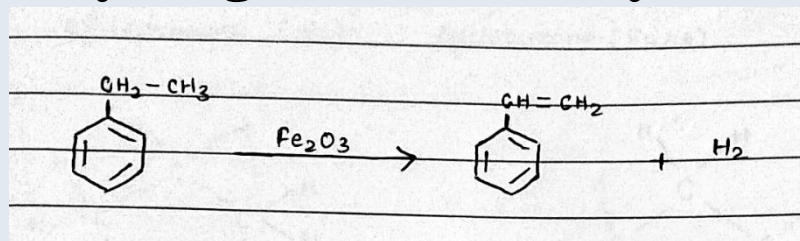

Catalyst- Fe₂O₃

Q(36). Match the polymer in Group I to the polymer characteristic in Group II

Group I

Group II

P. Polyethylene

I. Elastomer

Q. Phenol-formaldehyde polymer

II. Fiber

R. Polyisoprene

III. Thermoplastic

S. Polyester

IV. Thermosetting Polymer

Choose the correct set of combinations.

(A) P-III, Q-IV, R-I, S-II

(B) P-IV, Q-II, R-III, S-I

(C) P-III, Q-II, R-I, S-IV

(D) P-IV, Q-III, R-I, S-II

(GATE 2012)

Ans:- (A) P-III, Q-IV, R-I, S-II

Thermoplastic Polymer:-

- These are the plastics which get deformed easily on heating and can be bent easily.
- Examples: Polythene, PVC, polypropylene, polystyrene, and acrylics etc.

Thermosetting Polymer:-

- These are the plastics which when molded once, cannot be softened by heating.
- Examples: Phenol-formaldehyde (Bakelite), Melamine, polyurethane, unsaturated polyesters, phenolics, and silicones etc.

Elastomer:-

- An elastomer is a polymer with the property of elasticity. In other words, it is a polymer that deforms under stress and returns to its original shape when the stress is removed.
- Most of elastomers are rubbers.

Examples: Natural Rubber (NR), Polyisoprene, Polybutadiene, Styrene-butadiene Rubber (copolymer of polystyrene and polybutadiene, SBR), Nitrile Rubber (copolymer of polybutadiene and acrylonitrile, NBR), also called Buna N rubbers.

Fiber:-

- It is a piece of material that is long, thin and flexible, like a length of thread.

Examples: synthetic fibers - nylon (polyamide) or dacron (polyester), Cellulose regenerated fibers (rayon).

Q(37). Match the polymerization mechanisms in Group I with the corresponding polymers in Group II.

GROUP I

P. Chain growth/addition polymerisation

Q. Step growth / condensation polymerisation

GROUP II

I. Polyethylene,

II. Polyvinyl chloride

III. Polyethylene terephthalate

Choose the correct set of combinations.

(A) P – III; Q – I, II

(B) P – I, II; Q – III,

(C) P – II, III; Q – I

(D) P – I; Q – II, III

(GATE 2011)

Ans:- (B) P – I, II ;Q – III,

S.No	Addition Polymerization	Condensation polymerization
1.	Monomer must have at least a double bond or triple bond	Monomer must have at least two similar or different functional group
2.	Has no by product	Produces by products such as water, ammonia, HCl
3.	Addition of monomer results in a polymer	Monomers condensed to give a polymer
4.	Produces thermoplastics	Produces thermosets
5.	Results in homochain polymers	Results in hetero-chain polymers
6.	Examples:-polyvinyl chloride (PVC), polyethylene, polypropylene, poly tetrafluoroethen or TEFLON, etc.	Examples:- Bakelite, nylon, polyester(PET) etc.

Use Code: DEVENDRAPOONIA to get 10% off on Plus Subscription

Q(38). Which ONE of the following sequences is arranged according to INCREASING calorific value ?

- (A) Producer gas, Natural gas, Water gas
- (B) Natural gas, Producer gas, Water gas
- (C) Producer gas, Water gas, Natural gas
- (D) Water gas, Natural gas, Producer gas

(GATE 2011)

Ans:- (C) Producer gas, Water gas, Natural gas

Calorific value (heat value of the fuel) :-

- The amount of heat released by burning of unit quantity of the fuel.
- Measured in units of energy per amount of material, e.g. kJ/kg.
- The calorific value of the fuel can be measured by a device called as Bomb Calorimeter.
- The term calorific value of the IC engines fuels is very important term.
- The fuels for the IC engines are selected on the basis of the calorific value of the fuel. If the fuel has higher calorific value it will have tendency to produce more power in the engine.
- The fuels with less calorific value tend to burn inefficiently thus causing lots of exhaust and air-pollution.

Use Code: DEVENDRAPOONIA to get 10% off on Plus Subscription

Q(39). The CORRECT sequence of process equipment used in the production of sulphuric acid from sulphur by contact process is

- (A) burner, catalytic converter, 98% sulphuric acid absorption tower, oleum absorption column
- (B) catalytic converter, oleum absorption column, 98% sulphuric acid absorption tower, burner
- (C) burner, catalytic converter, oleum absorption column, 98% sulphuric acid absorption tower
- (D) burner, oleum absorption column, catalytic converter, 98% sulphuric acid absorption tower

(GATE 2011)

Use Code: DEVENDRAPOONIA to get 10% off on Plus Subscription

Ans:- (C) burner, catalytic converter, oleum absorption column, 98% sulphuric acid absorption tower

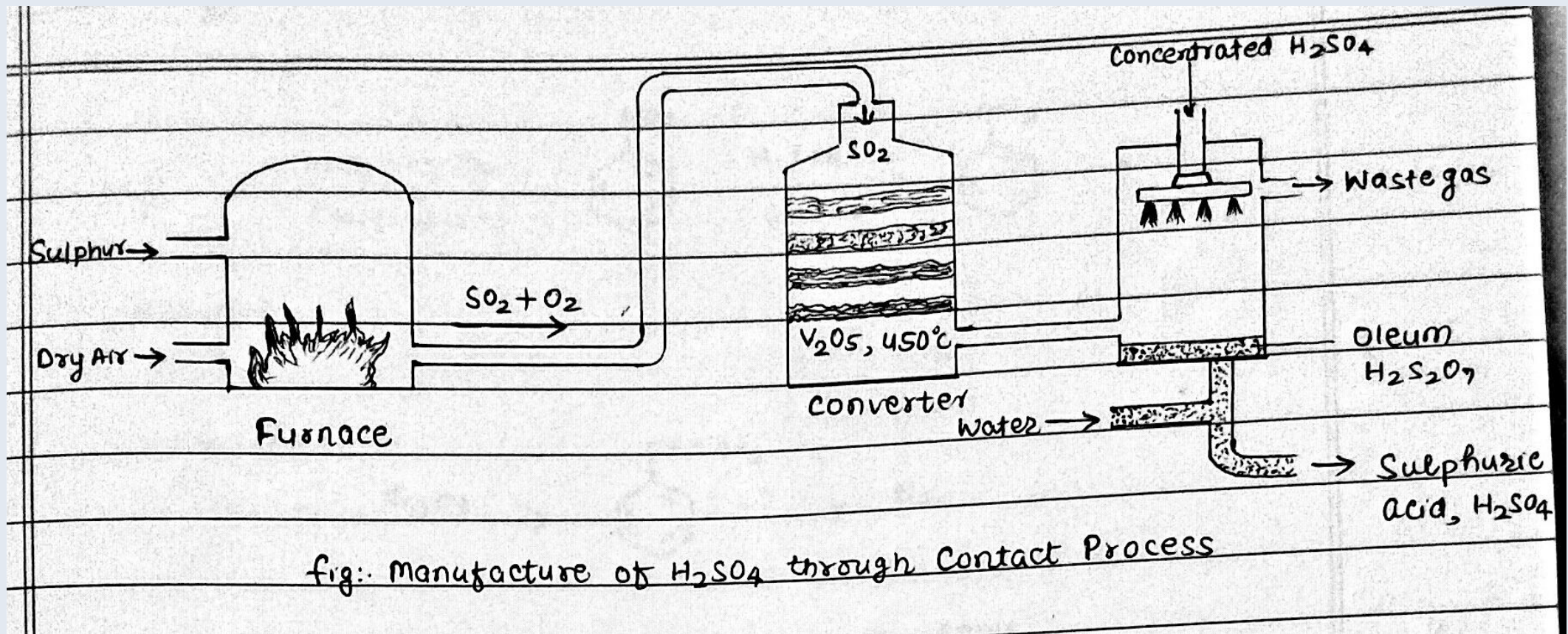

Contact Process:-

1	Production of SO ₂ from Sulphur	$S + O_2 \longrightarrow SO_2$
2	Purification of sulphuric dioxide	To remove dust particle, oxides of iron & arsenic
3	Catalytic oxidation of SO ₂ to SO ₃	$2SO_2 + O_2 \longrightarrow 2SO_3 + \text{heat}$
4	Conversion of SO ₃ to oleum	$SO_3 + H_2SO_4 \longrightarrow H_2S_2O_7$
5	Dilution of oleum to sulphuric acid	$H_2S_2O_7 + H_2O \longrightarrow 2H_2SO_4$

Q(40). Hydrotreating is used for

- (A) removal of water from crude oil,
- (B) treatment of crude oil with water,
- (C) improving octane number of gasoline,
- (D) removal of sulphur and nitrogen from petroleum fractions

(GATE 2011)

Ans:- (D) removal of sulphur and nitrogen from petroleum fractions

S.N O.	Catalytic Cracking	Hydro-cracking
1.	Carbon rejection	Hydrogen addition
2.	Riser-regenerator-configuration	Down flow packed bed
3.	LPG/gasoline	Kerosene/diesel
4.	Product rich in unsaturated components	Few aromatics, low S- and N-content in product

Use Code: DEVENDRAPOONIA to get 10% off on Plus Subscription

Q(41). Zeolite ZSM-5 is added to commercial FCC catalyst for

- (A) promoting SO₂ reduction
- (B) promoting CO oxidation
- (C) improving tolerance to metal content in feed
- (D) enhancing Octane number

(GATE 2011)

Use Code: DEVENDRAPOONIA to get 10% off on Plus Subscription

Ans:-(D) Enhancing Octane number

Fluidized Catalytic Cracking (FCC):-

- Important conversion process in petroleum refineries.
- High molecular weight long chain hydrocarbons are cracked into the small molecules like Gasoline.
- Raw Material – Heavy Gas oil or Vacuum gas oil.
- Final product – Low mol. wt. small chain HCs
- Catalyst used- zeolite

Use Code: DEVENDRAPOONIA to get 10% off on Plus Subscription

Process Flow Diagram of FCC:-

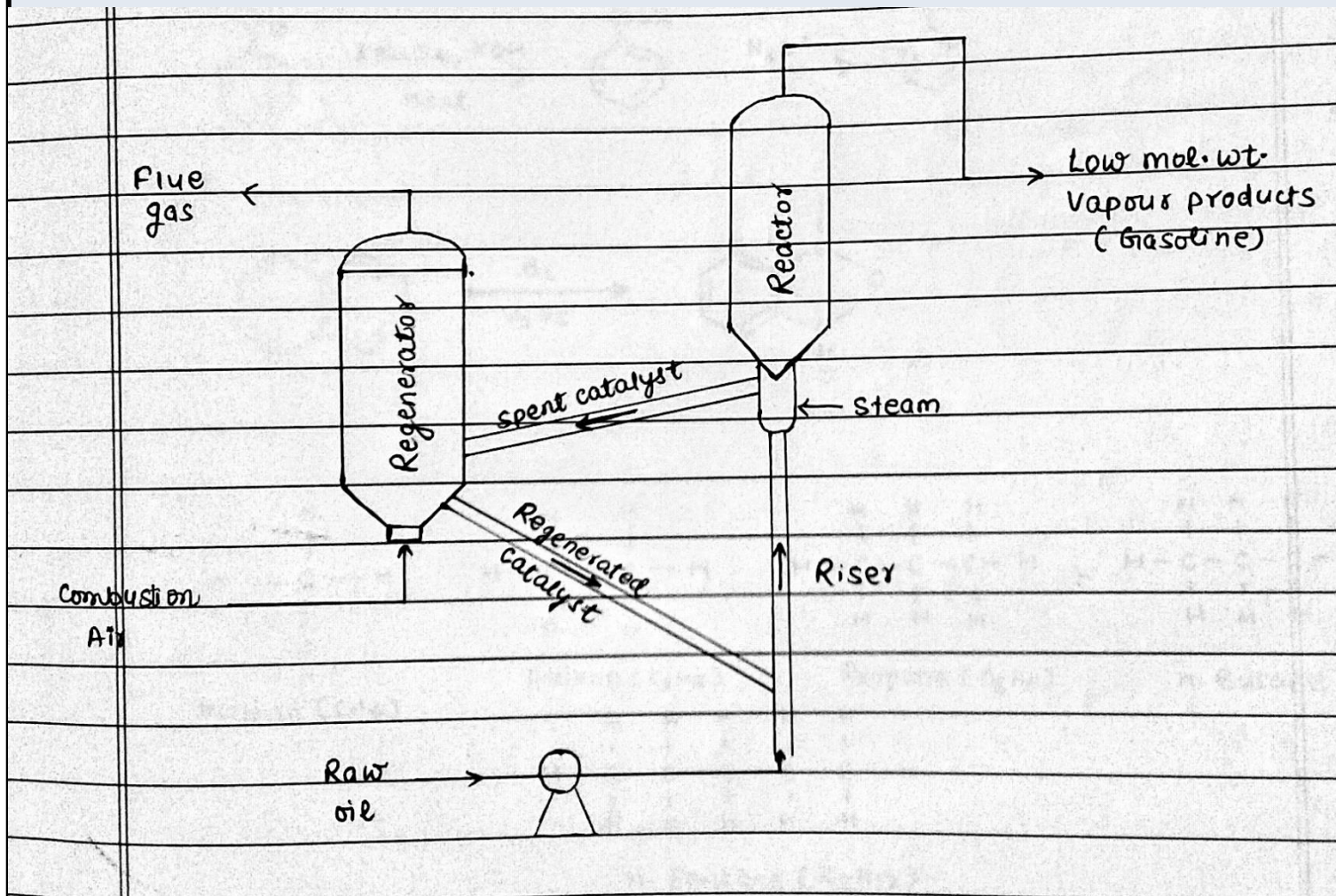

Key Points:-

- ❖ Regenerator- Exothermic Reaction
- ❖ Reactor- Endothermic Reaction
- ❖ Cracking reaction time – 2-4 sec

Q(42). Match the reactions in Group I with the products in Group II.

Group I

P. Ammoxidation

Q. Nitration

R. Dehydrogenation

S. Oxidation

Group II

I. Aniline from benzene

II. Benzoic acid from toluene

III. Acrylonitrile from propylene

IV. Styrene from ethylbenzene

Choose the correct set of combinations.

(A) P – III, Q – I, R – IV, S – II

(B) P – IV, Q – I, R – III, S – II

(C) P – I, Q – III, R – IV, S – II

(D) P – I, Q – II, R – III, S – IV

(GATE 2011)

Ans:- (A) P – III, Q – I, R – IV, S – II

Amoxidation (Acrylonitrile from propylene):-

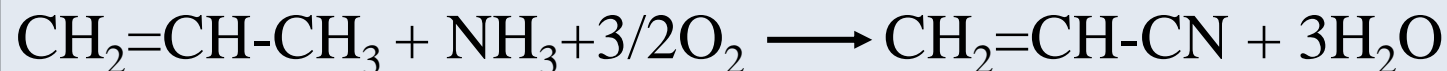

Nitration (Aniline from benzene):-

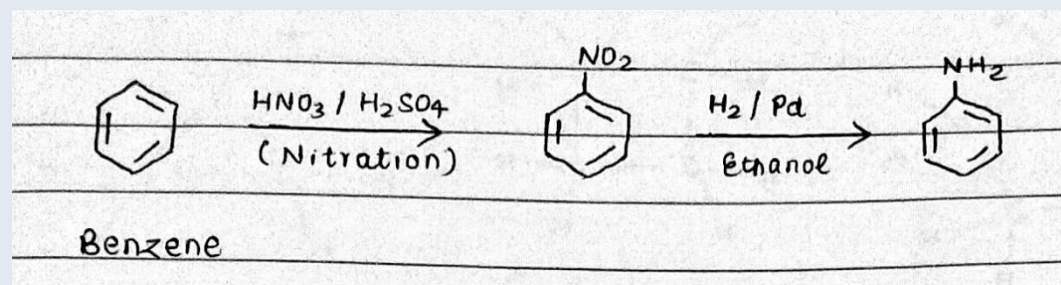

Dehydrogenation (Styrene from ethylbenzene):-

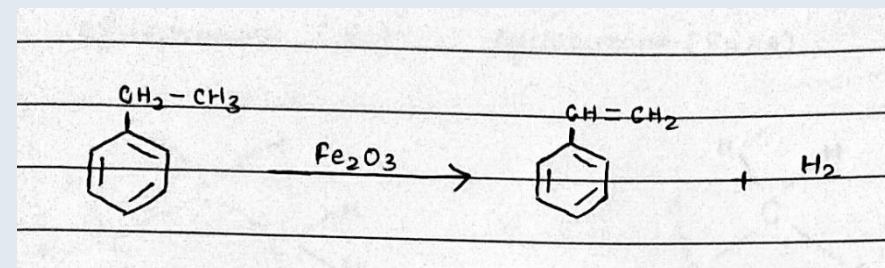

Oxidation (Benzoic acid from toluene):-

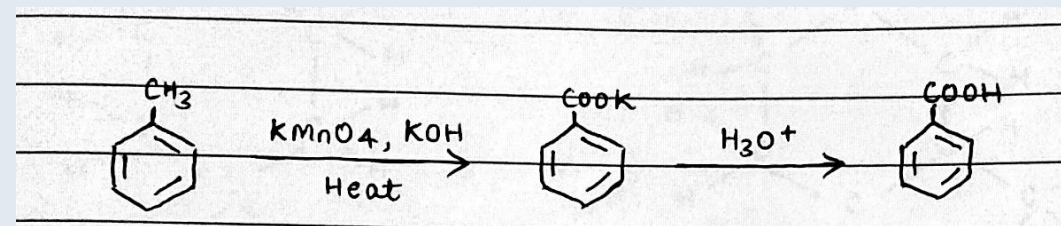

Q(43). In the manufacture of caustic soda from brine, which ONE of the following statements is TRUE ?

(A) The membrane cell CANNOT produce concentrated NaOH solution, and CANNOT tolerate calcium and magnesium ions in the feed brine.

(B) The membrane cell CANNOT produce concentrated NaOH solution, but CAN tolerate calcium and magnesium ions in the feed brine.

(C) The membrane cell CAN produce concentrated NaOH solution, but CANNOT tolerate calcium and magnesium ions in the feed brine.

(D) The membrane cell CAN produce concentrated NaOH solution, and CAN tolerate calcium and magnesium ions in the feed brine.

(GATE 2010)

Use Code: DEVENDRAPOONIA to get 10% off on Plus Subscription

Ans:- (C) The membrane cell CAN produce concentrated NaOH solution, but CANNOT tolerate calcium and magnesium ions in the feed brine.

Advantages:-

- More concentrated brine is produced.
- Purer and concentrated products (28% NaOH containing 50ppm of NaCl, 40% NaOH product) are produced.

Disadvantages:-

- Readily clogged of membrane.
- Pretreatment of brine is required to remove calcium and magnesium salts.

Q(44). For making superphosphate by acidulation of phosphate rock, use of nitric acid is desirable, because

- (A) nitric acid is less expensive than sulphuric acid
- (B) Availability of nitrogen enhances the value of the superphosphate as a fertilizer
- (C) The process produces non-hygroscopic superphosphate
- (D) The process produces superphosphate having higher phosphorus content than the sulphuric acid process

(GATE 2010)

Ans:- (D) The process produces superphosphate having higher phosphorus content than the sulphuric acid process.



Nitric and mixed acid acidulation of phosphate rock:-

Nitric acid produces triple the superphosphate which in turn has higher phosphorous content compared to that of sulphuric acid.

Q(45). Match the processes in Group I with the products in Group II.

GROUP I

P. Claus process

Q. Linde process

R. Lurgi process

GROUP II

I. Syngas

II. Oxygen

III. Sulphur

Choose the correct set of combinations.

(A) P-I, Q-II, R-III

(B) P-II, Q-I, R-III

(C) P-III, Q-I, R-II

(D) P-III, Q-II, R-I

(GATE 2010)

Use Code: DEVENDRAPOONIA to get 10% off on Plus Subscription

Ans:-(D) P-III, Q-II, R-I

Claus Process (*sulfur recovery unit (SRU)*):-

- The Claus process is the most significant gas desulfurizing process, recovering elemental sulfur from gaseous hydrogen sulfide.
- Hydrogen sulfide produced in the hydro-desulfurization of refinery naphthas and other petroleum oils, is converted to sulfur in Claus plants.
- The reaction consists in two steps:

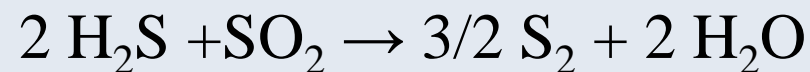
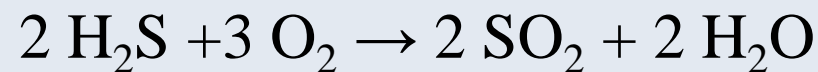

Use Code: DEVENDRAPOONIA to get 10% off on Plus Subscription

Linde process:-

- This method makes use of Joule Thomson effect and is used to liquify air or any other gas.
- The production of liquefied gases like H_2 , O_2 , N_2 and He have very low T_c values and hence Joule Thomson effect applied to bring in effective cooling.

Lurgi process (Coal gasification):-

- Lurgi dry-ash gasification technology has since been used worldwide to produce synthesis gas (syngas).

Q(46). Match each of the following techniques of polymerization in Group I, with the corresponding process characteristics in Group II.

Group I

Group II

P. Bulk

I. Polymer with very high molecular weight can be obtained

Q. Solution

II. Heat removal is crucial but very difficult

R. Suspension

III. Small amount of undesired low molecular weight polymer is formed

S. Emulsion

IV. Polymer concentration in the product stream is low.

Choose the correct set of combinations.

(A) P-I, Q-II, R-III, S-IV

(B) P-II, Q-IV, R-III, S-I

(C) P-I, Q-II, R-IV, S-III

(D) P-III, Q-II, R-IV, S-I

(GATE 2010)

Use Code: DEVENDRAPOONIA to get 10% off on Plus Subscription

Ans:-(B) P-II, Q-IV, R-III, S-I

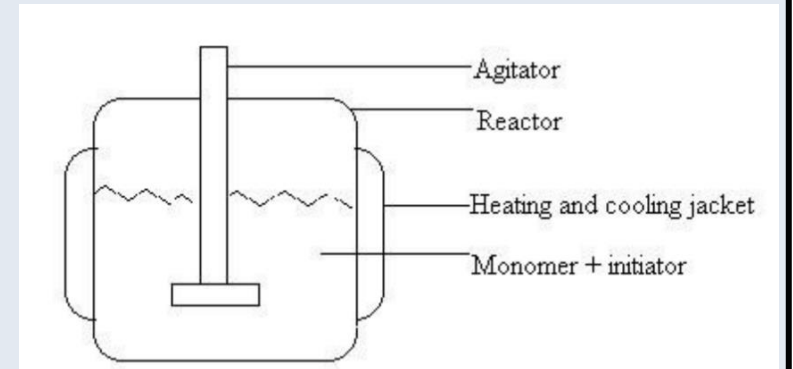

Bulk polymerization:-

- Bulk polymerization are those in which only the monomer (or reactants) plus possibly an initiator or a catalyst are added to a reactor vessel.
- In other type of polymerization, a solvent or water is also added.
- Heat removal is crucial but very difficult.
- Bulk polymerization often produce higher purity polymers and in general require simpler separation procedures.
- Examples:-Polystyrene, Polyethylene, Polypropylene, PET and nylon.

Use Code: DEVENDRAPOONIA to get 10% off on Plus Subscription

Solution polymerization:-

- Polymer concentration in the product stream is low.
- Solution polymerization is used when polymer required in solution form.
- Surface coatings and impregnated compositions are the applications where polymer is applied in solution.

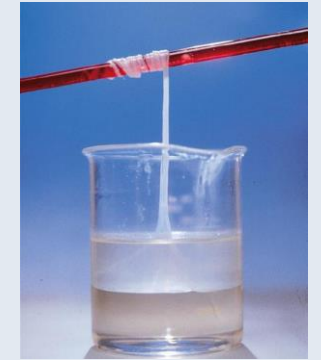

Suspension polymerization:-

- Small amount of undesired low molecular weight polymer is formed.
- Suspension polymerization process are used for about 90% of all PVC produces.
- Major amount of polymers are produced using other olefins, including styrene and methacrylate.

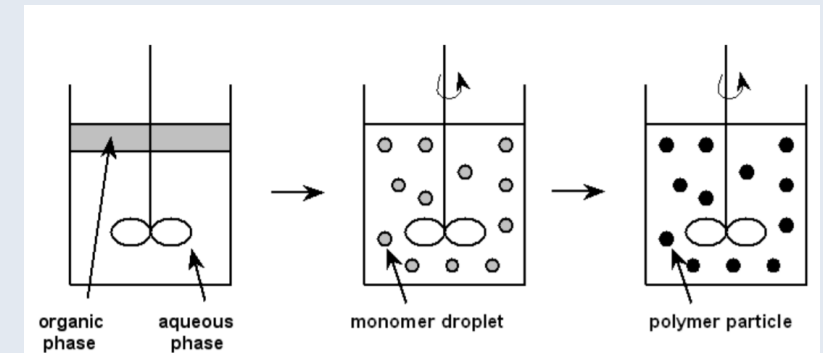

Emulsion polymerization:-

- Produces polymers with very high molecular weights.
- It is used for the production of polymers requiring high molecular weights such as Styrene Butadiene elastomer (SBR) and Teflon.

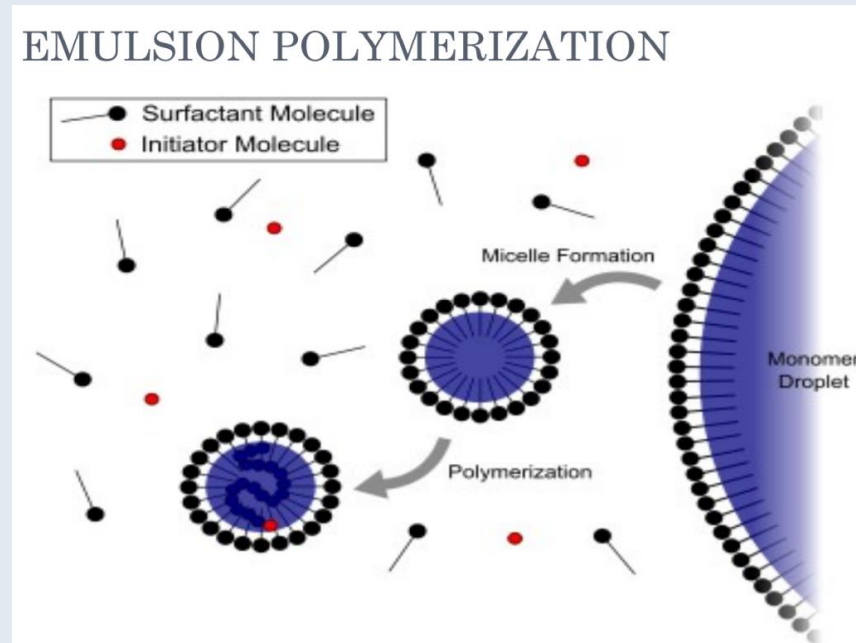

Q(47). Match each of the polymers in Group I, with the raw material in Group II from which they are made

Group I	Group II
P. Polyester	I. Ethylene glycol
Q. Polyamide	II Adipic acid
R. Viscose rayon	III. Cellulose
S. Epoxy resin	IV. Bisphenol

Choose the correct set of combinations.

(A) P-I, Q-II, R-III, S-IV

(B) P-II, Q-I, R-III, S-IV

(C) P-I, Q-II, R-IV, S-III

(D) P-III, Q-II, R-IV, S-I

(GATE 2010)

Ans:- (A) P-I, Q-II, R-III, S-IV

S.No.	Polymer	Monomers
1.	Epoxy resin	Bisphenol
2.	Viscous rayon	cellulose
3.	Polyamide (Nylon)	Adipic Acid + Hexamethylene diamine
4.	Polyester (PET)	Terephthalic Acid + Ethylene Glycol

Use Code: DEVENDRAPOONIA to get 10% off on Plus Subscription

Epoxy Resin from Bisphenol:-

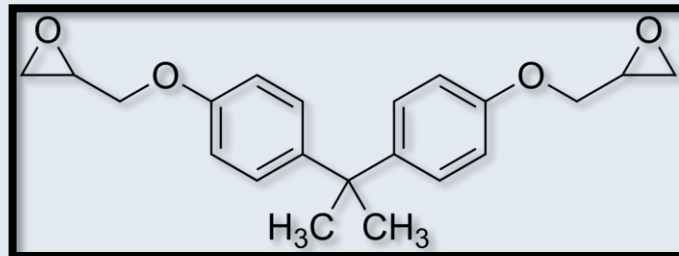
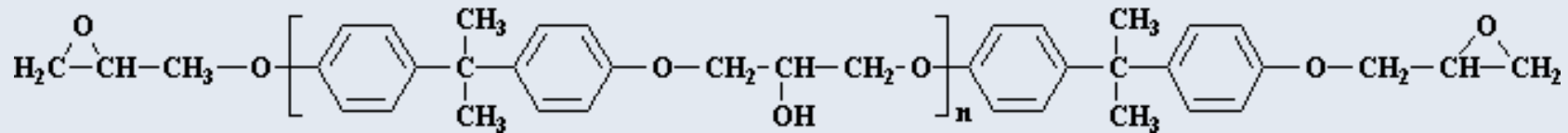
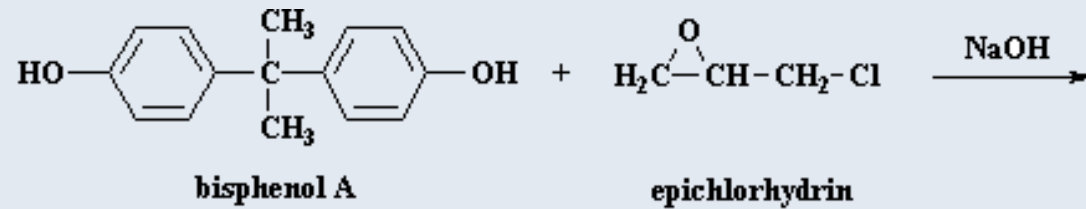

Q(48). In petroleum refining operations, the process used for converting paraffins and naphthenes to aromatics is

(A) Catalytic reforming

(B) Catalytic cracking

(C) Hydrocracking

(D) Alkylation

(GATE 2009)

Use Code: DEVENDRAPOONIA to get 10% off on Plus Subscription

Ans:- (A) Paraffins and naphthenes to aromatics

- The reforming process is a catalytic process which converts low octane naphthas into higher octane reformat products.
- Process re-arranges or re-structures the hydrocarbon molecules in the naphtha feedstocks as well as breaking some of the molecules into smaller molecules.
- Among the same carbon number compounds, the order of RONC is (Research Octane Number) Paraffins < Naphthenes < Aromatics.
- Branched paraffins also have high octane. It increases with degree of branching.

Q(49). The active component of catalysts used in steam reforming of methane to produce synthesis gas is

- (A) Nickel
- (B) Iron
- (C) Platinum
- (D) Palladium

(GATE 2009)

Ans:-(A) Nickel

- Steam reforming is a method for producing hydrogen, carbon monoxide, or other useful products from hydrocarbon fuels such as natural gas.
- The steam methane reformer is widely used in industry to make hydrogen.

steam methane reforming (SMR):-

- It is the most common method of producing commercial bulk hydrogen at about 95% of the world production
- Hydrogen is used in the industrial synthesis of ammonia and other chemicals.
- At high temperatures (700 – 1100 °C) and in the presence of a metal-based catalyst (nickel), steam reacts with methane to yield carbon monoxide and hydrogen.



Q(50). Match the product in Group I with the name of the process in Group II.

GROUP I

GROUP II

P. Sodium carbonate

1. Haber

Q. Ammonia

2. Solvay

R. Sulphuric acid

3. Fischer-Tropsch

4. Contact

Choose the correct set of combinations.

(A) P-2, Q-1, R-4

(B) P-4, Q-1, R-2

(C) P-3, Q-4, R-2

(D) P-2, Q-1, R-3

(GATE 2009)

Use Code: DEVENDRAPOONIA to get 10% off on Plus Subscription

Ans:- (A) P-2, Q-1, R-4

Solvay Process:-

- The Solvay process or ammonia-soda process is the major industrial process for the production of sodium carbonate & sodium hydrogen carbonate.
- The ingredients for this process are readily available and inexpensive: salt brine (from inland sources or from the sea) and limestone (from mines).
- The Solvay process results in soda ash (Na_2CO_3) from brine (NaCl) and from limestone (CaCO_3).
- $2 \text{NaCl} + \text{CaCO}_3 \rightarrow \text{Na}_2\text{CO}_3 + \text{CaCl}_2$
- $\text{NaCl} + \text{CO}_2 + \text{NH}_3 + \text{H}_2\text{O} \rightarrow \text{NaHCO}_3 + \text{NH}_4\text{Cl}$

Use Code: DEVENDRAPOONIA to get 10% off on Plus Subscription

Haber Process:-

- The Haber Process combines nitrogen from the air with hydrogen derived mainly from natural gas (methane) into ammonia.



- The reaction is reversible and the production of ammonia is exothermic.
- The catalyst is actually slightly more complicated than pure iron. It has potassium hydroxide added to it as a promoter - a substance that increases its efficiency.

Contact Process:-

1	Production of SO ₂ from Sulphur	$S + O_2 \longrightarrow SO_2$
2	Purification of sulphuric dioxide	To remove dust particle, oxides of iron & arsenic
3	Catalytic oxidation of SO ₂ to SO ₃	$2SO_2 + O_2 \longrightarrow 2SO_3 + \text{heat}$
4	Conversion of SO ₃ to oleum	$SO_3 + H_2SO_4 \longrightarrow H_2S_2O_7$
5	Dilution of oleum to sulphuric acid	$H_2S_2O_7 + H_2O \longrightarrow 2H_2SO_4$

Q(51). Match the product in Group I to the raw material in Group II.

GROUP I

P. Ethylene

Q. Methanol

R. Phthalic anhydride

GROUP II

1. Natural gas

2. Synthesis gas

3. Naphtha

4. Naphthalene

Choose the correct set of combinations.

(A) P-1, Q-2, R-3

(B) P-2, Q-1, R-4

(C) P-3, Q-1, R-4

(D) P-3, Q-2, R-4

(GATE 2009)

Ans:-(D) P-3, Q-2, R-4

Hydrocarbon Steam Cracking for Petrochemicals:-

Reaction:-

- $C_xH_y + H_2O + O_2 \rightarrow C_2H_4 + C_2H_6 + C_2H_2 + H_2 + CO + CO_2 + CH_4 + C_3H_6 + C_3H_8 + C_4H_{10} + C_4H_8 + C_6H_6 + C + \text{Heavy oils}$
- Typical feed stocks are Naphtha & LPG.
- When they are subjected to steam pyrolysis, then good number of petrochemicals can be produced.
- These include primarily ethylene and acetylene along with other compounds such as propylene, butadiene, aromatics (benzene, toluene and xylene) and heavy oil residues.

Hydrocarbon Steam Cracking for Petrochemicals:-

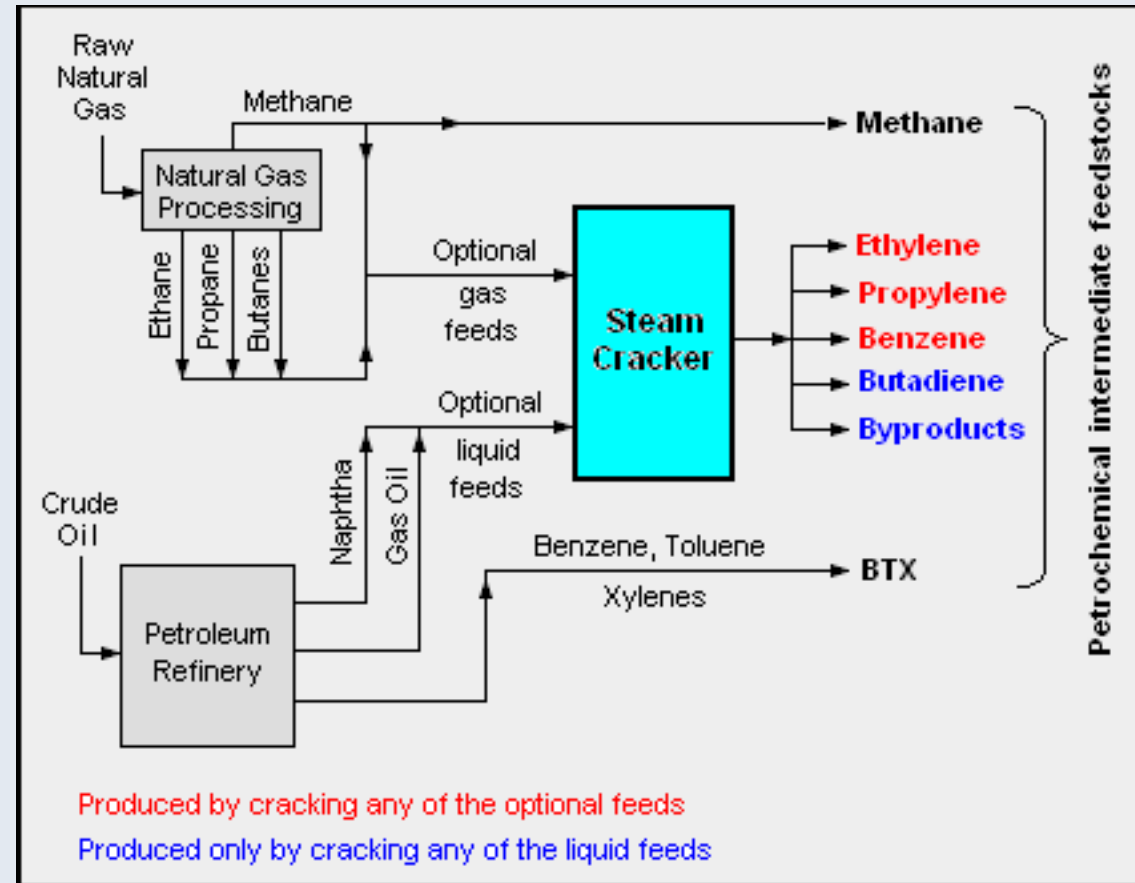

Hydrocarbon Steam Cracking for Petrochemicals:-

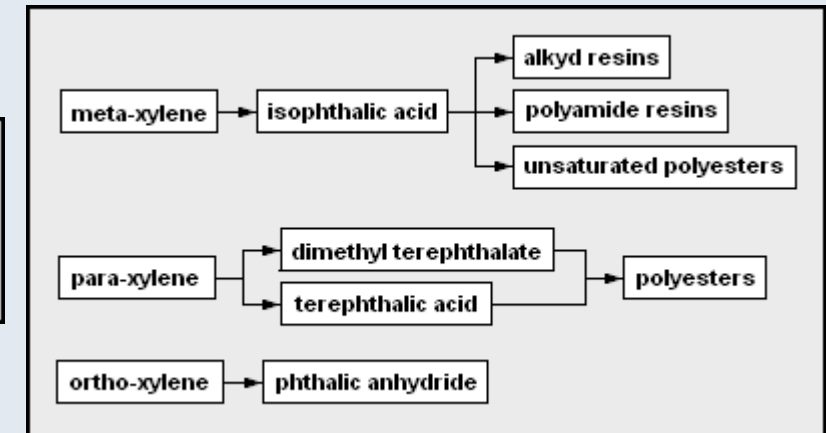
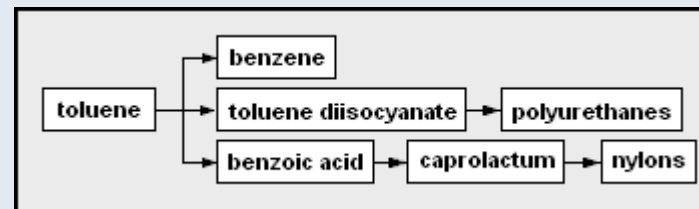
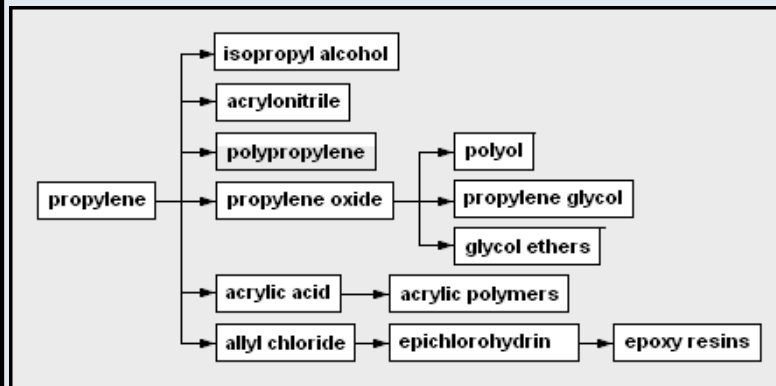
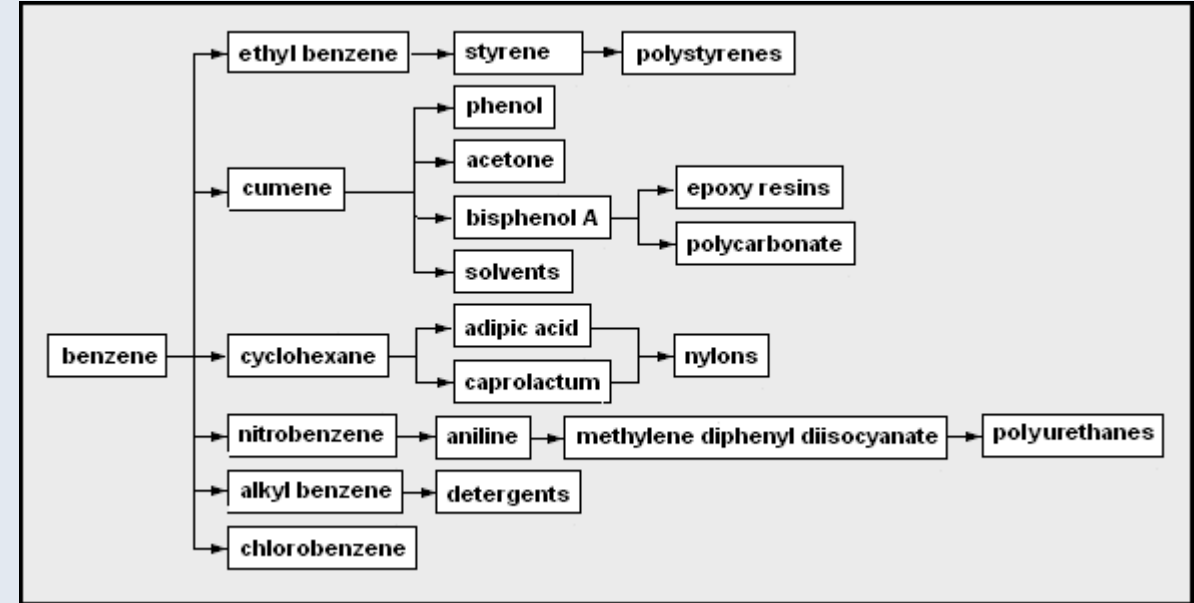
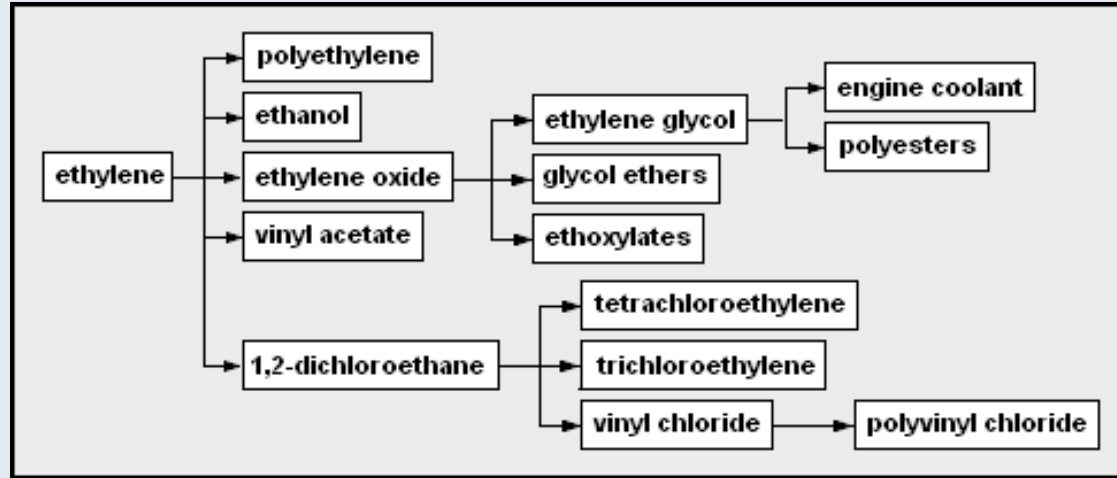

Use Code: DEVENDRAPOONIA to get 10% off on Plus Subscription

Manufacture of Methanol from Synthesis Gas:-

Synthesis gas is $H_2 + CO$

When synthesis gas is subjected to high pressure and moderate temperature conditions, it converts to methanol.

Reactions

• Desired:

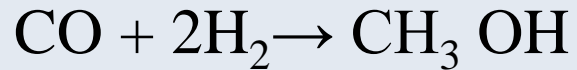

• Side reactions:

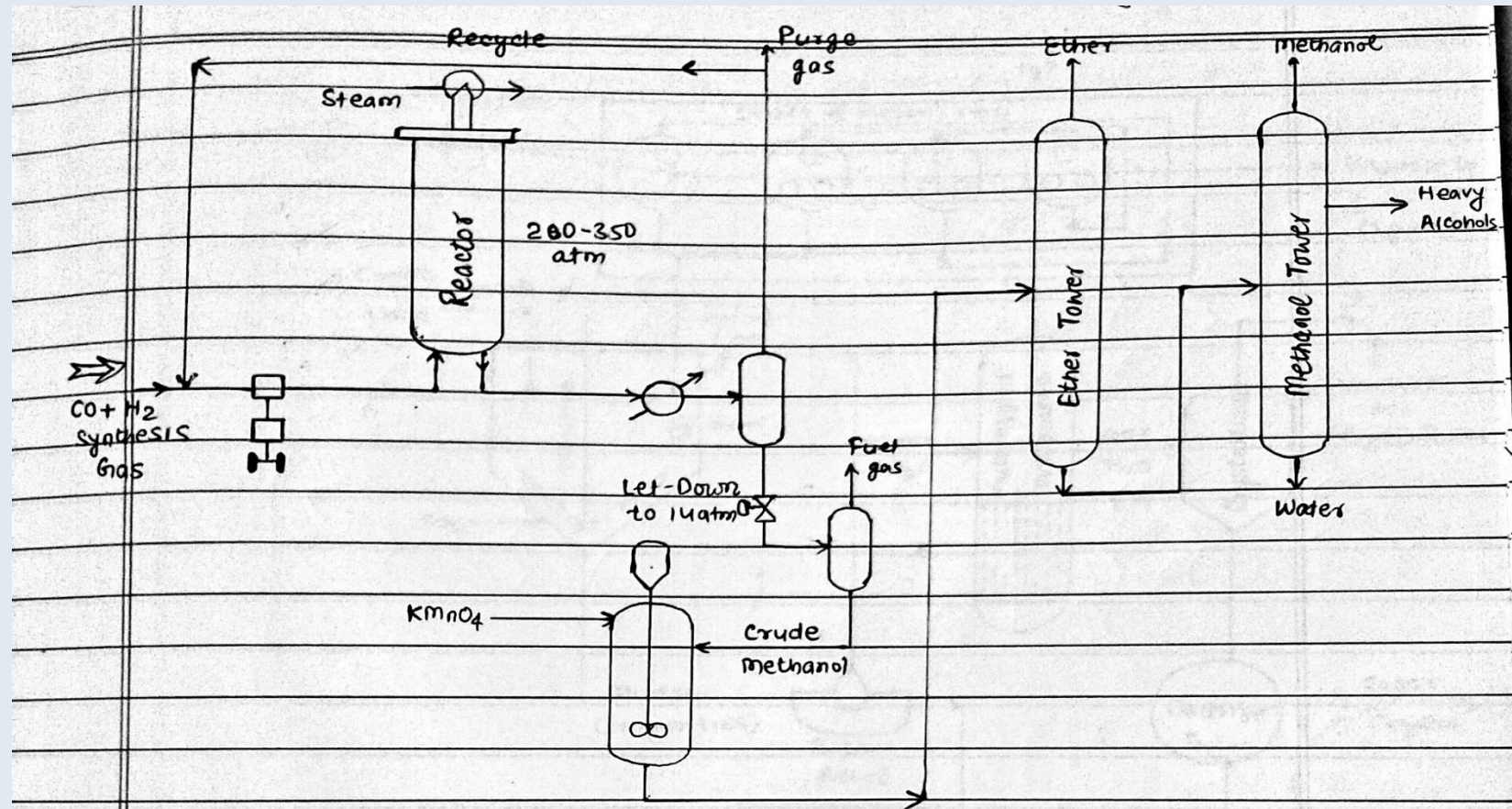
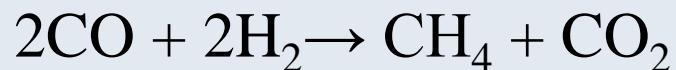
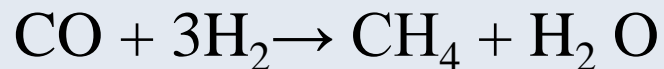
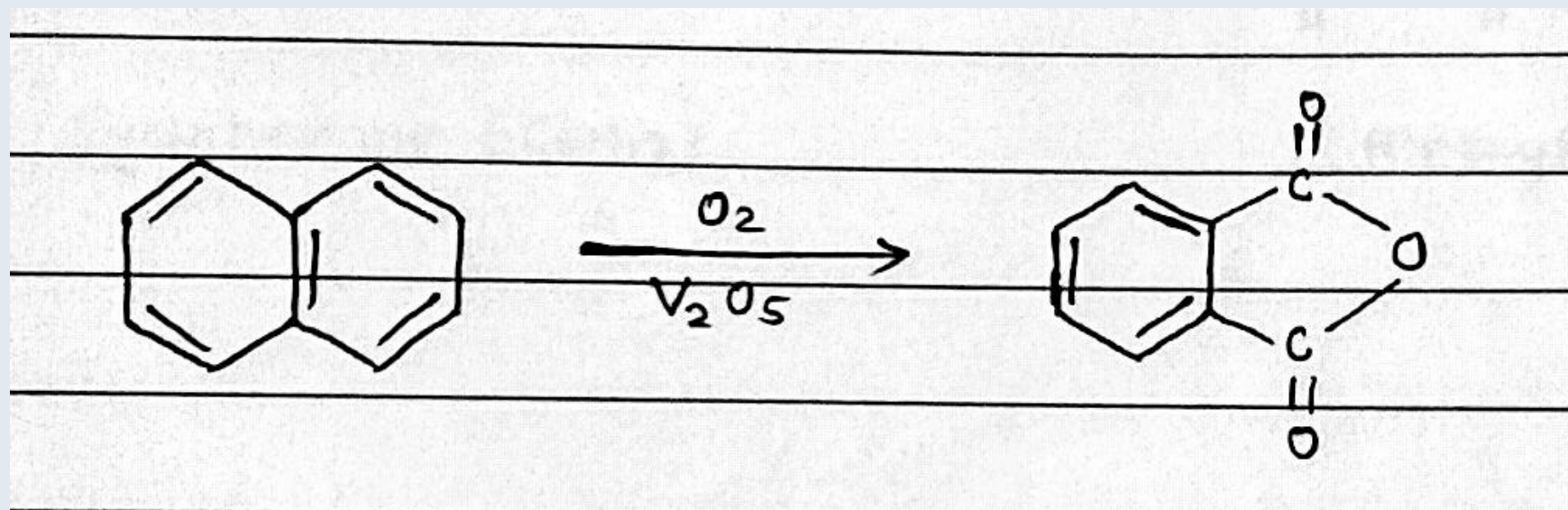

fig: Manufacture of methanol from synthesis Gas

Oxidation of Naphthalene to Phthalic Anhydride:-



- Catalyst: Vanadium pentoxide.
- Reaction is highly exothermic.

Q(52). Match the unit process in Group I with the industry in Group II.

GROUP I

P. Steam cracking

Q. Hydrocracking

R. Condensation

GROUP II

1. Petroleum refining

2. Petrochemicals

3. Polymers

4. Soaps and Detergents

Choose the correct set of combinations.

(A) P-1, Q-2, R-3

(B) P-2, Q-3, R-3

(C) P-1, Q-2, R-4

(D) P-2, Q-1, R-3

(GATE 2009)

Ans:-(D) P-2, Q-1, R-3

Hydrocarbon Steam Cracking for Petrochemicals:-

Reaction:-

- $C_xH_y + H_2O + O_2 \rightarrow C_2H_4 + C_2H_6 + C_2H_2 + H_2 + CO + CO_2 + CH_4 + C_3H_6 + C_3H_8 + C_4H_{10} + C_4H_8 + C_6H_6 + C + \text{Heavy oils}$
- Typical feed stocks are Naphtha & LPG.
- When they are subjected to steam pyrolysis, then good number of petrochemicals can be produced.
- These include primarily ethylene and acetylene along with other compounds such as propylene, butadiene, aromatics (benzene, toluene and xylene) and heavy oil residues.

Q(53). Which ONE of the following is NOT a major constituent of crude oil ?

(A) Paraffins

(B) Olefins

(C) Naphthenes

(D) Aromatics

(GATE 2008)

Use Code: DEVENDRAPOONIA to get 10% off on Plus Subscription

Ans:-(B) Olefins

Paraffins:- Paraffins refer to alkanes such as methane, ethane, propane, n and iso butane, n and iso pentane.

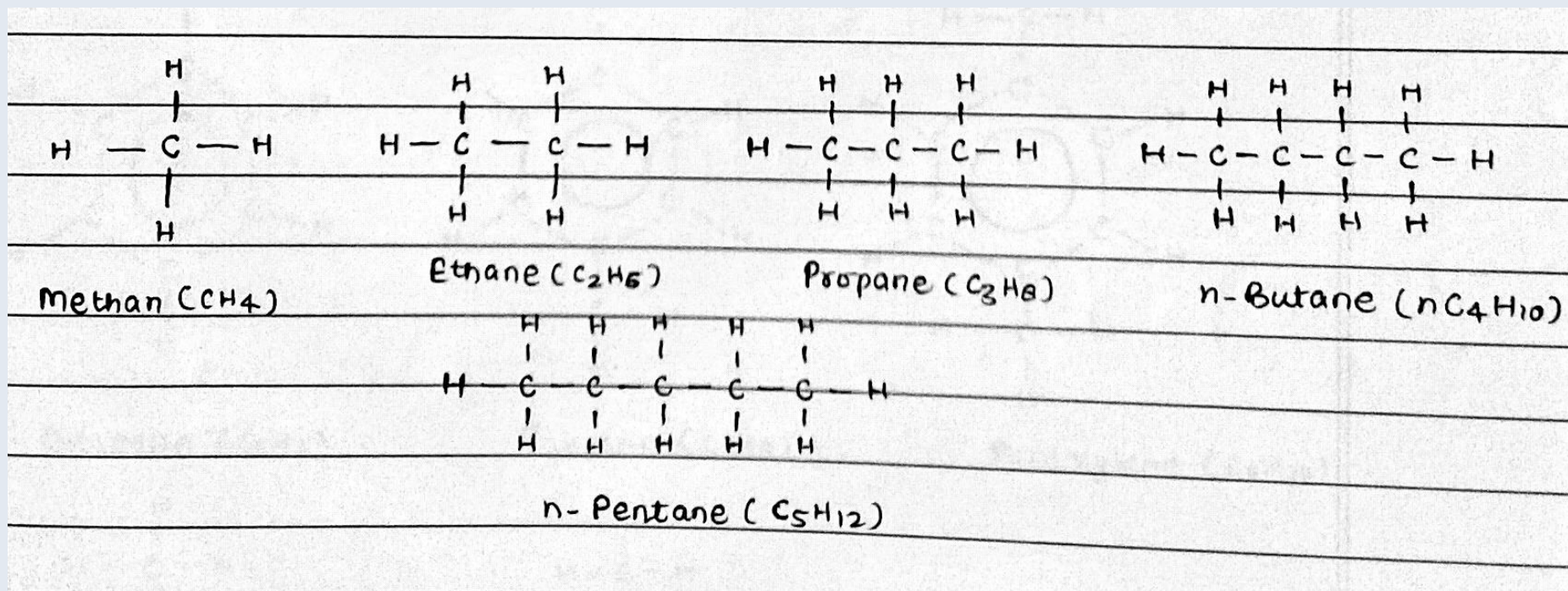

Olefins:- Alkenes such as ethylene, propylene and butylene are highly chemically reactive.

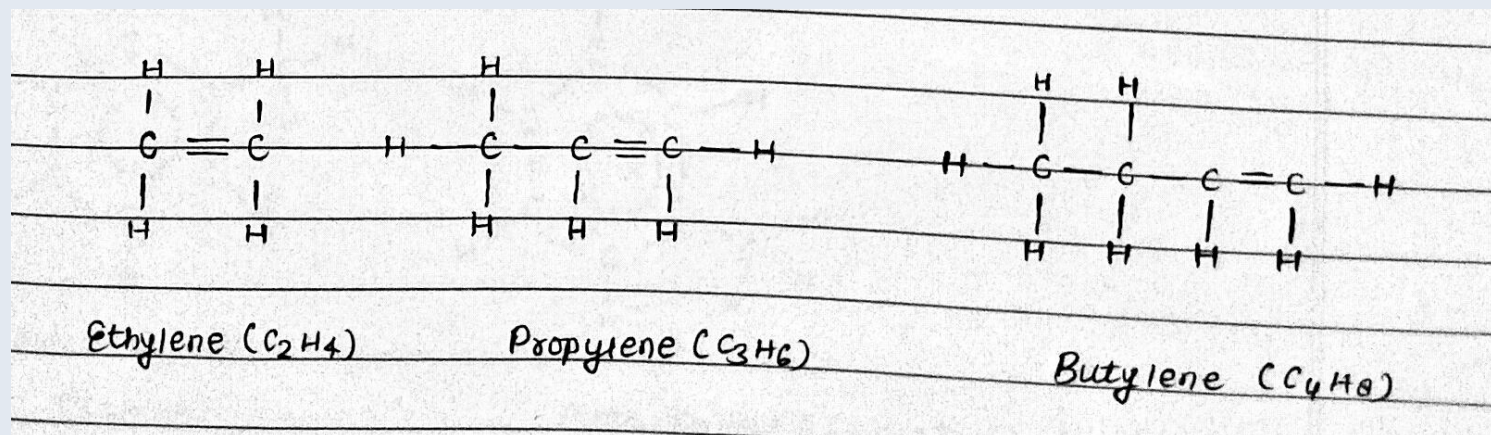

Naphthenes:- Naphthenes or cycloalkanes such as cyclopropane, methyl cyclohexane are also present in the crude oil. These compounds are not aromatic and hence do not contribute much to the octane number.

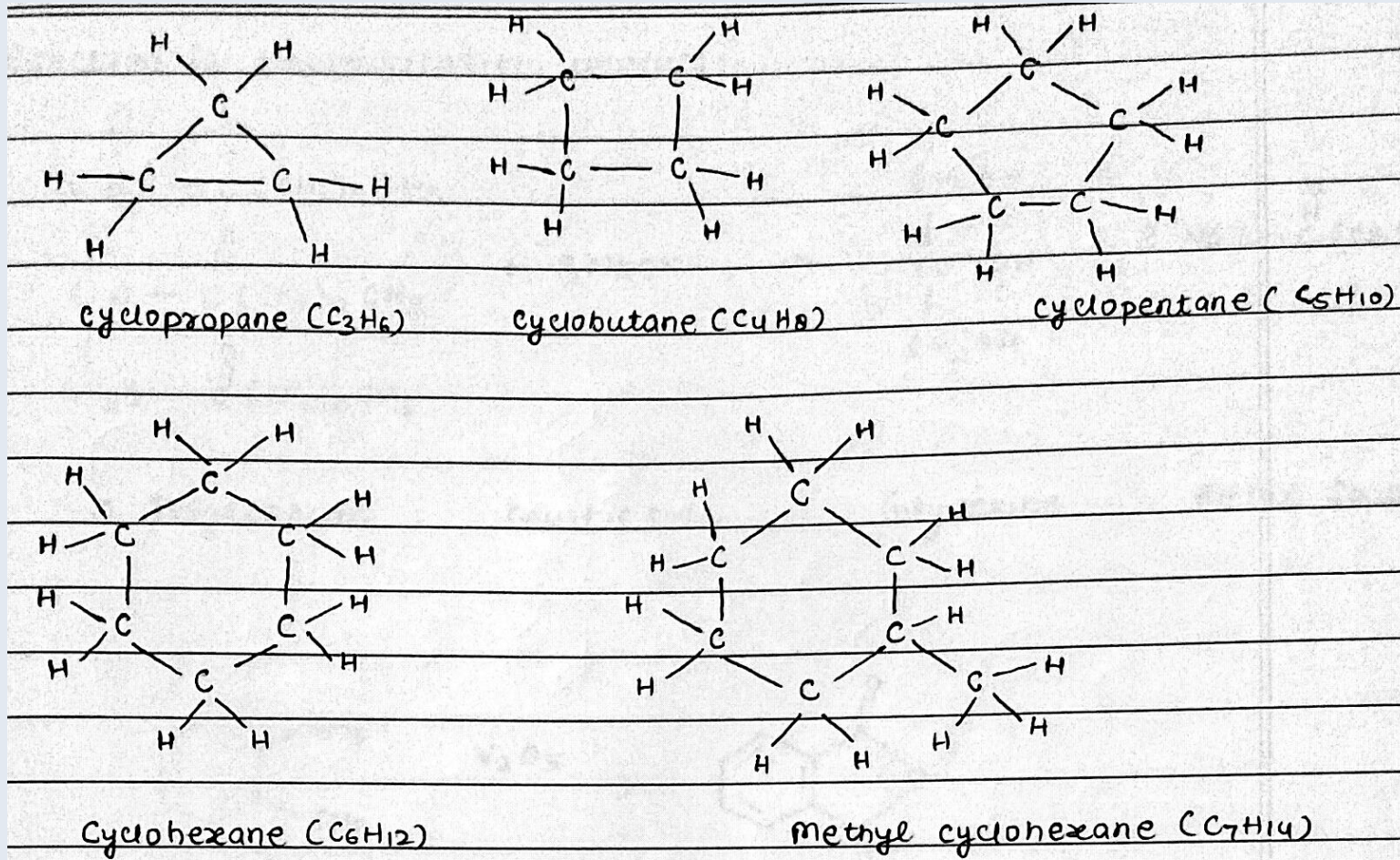

Aromatics:- Aromatics such as benzene, toluene o/m/p-xylene are also available in the crude oil. These contribute towards higher octane number products and the target is to maximize their quantity in a refinery process.

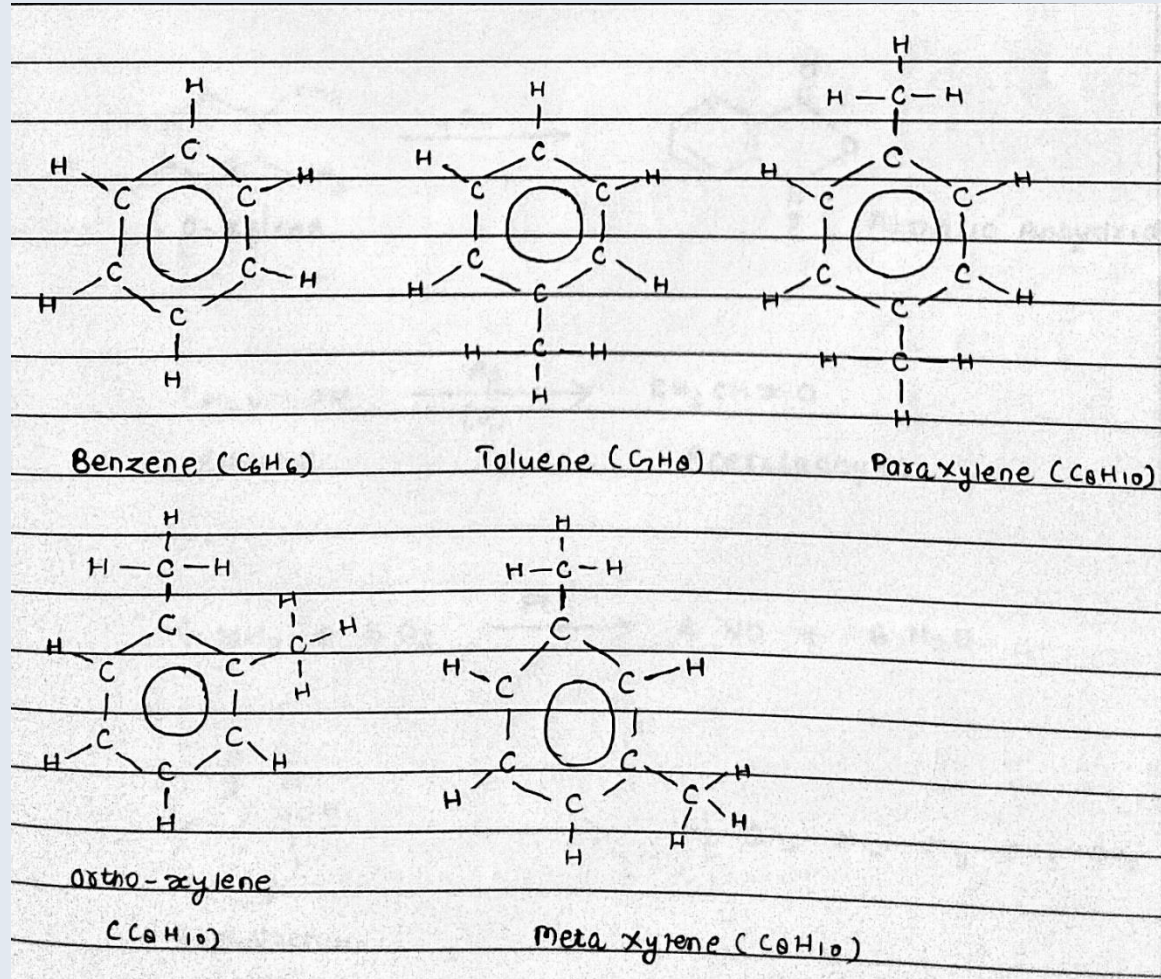

Use Code: DEVENDRAPOONIA to get 10% off on Plus Subscription

Q(54). Match the unit processes in Group 1 with the industries in Group 2

Group 1

(P) Saponification

(Q) Calcination

(R) Alkylation

Group 2

(1) Petroleum refining

(2) Synthetic fibres

(3) Cement

(4) Soaps and Detergents

Choose the correct set of combinations.

(A) P-1, Q-3, R-4

(B) P-2, Q-3, R-4

(C) P-4, Q-2, R-1

(D) P-4, Q-3, R-1

(GATE 2008)

Ans:- (D) P-4, Q-3, R-1

Saponification:-

- A mixture of tallow (animal fat), coconut oil, sodium hydroxide and salt are mixed in fixed proportion and fed to a reactor (Kettle or pan) with and heated with steam.
- The soap produced is the salt of a long chain carboxylic acid.

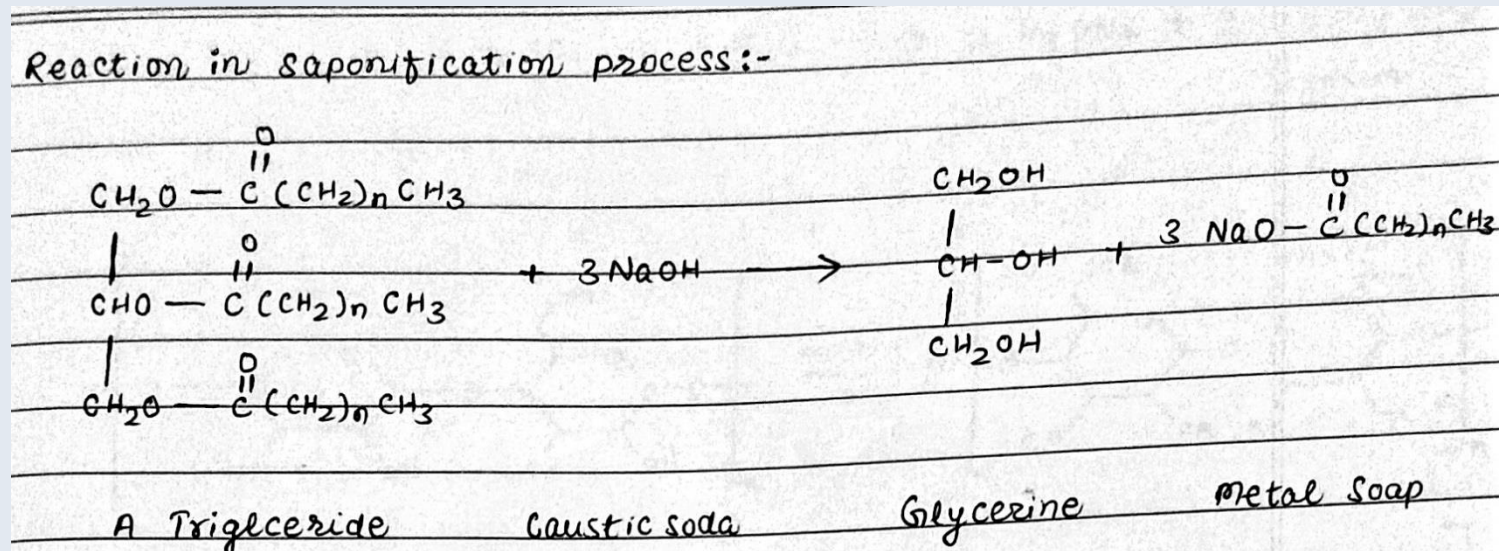

Calcination:-

- Calcination is a thermal treatment process and applied to ores and other solid materials to bring
 - a) thermal decomposition
 - b) phase transition and
 - c) to remove volatile fractions such as CO_2 , H_2O
- Material is heated below the melting point in rotary kiln or fluidized bed reactor.
- Calcination is done in the solid state.

Alkylation:-

- The basic purpose of alkylation is to enhance the octane number of the feed stock.
- The combination of olefins with paraffins or aromatics to form higher isoparaffins is termed alkylation.
- The reaction involved in aliphatic alkylation consists of conversion of iso-butane and butylenes to iso-octanes using HF catalyst.

➤ Reaction:-



Q(55). Which ONE of the following process sequences is used in the production of synthesis gas ?

- (A) Desulphurization, Steam reforming, Hot K_2CO_3 cycle
- (B) Steam reforming, Desulphurization, Hot K_2CO_3 cycle
- (C) Hot K_2CO_3 cycle, Steam reforming, Desulphurization
- (D) Hot K_2CO_3 cycle, Desulphurization, Steam reforming

(GATE 2008)

Ans:- (D) Hot K_2CO_3 cycle, Desulphurization, Steam reforming

- Potassium carbonate (K_2CO_3) is an alkaline salt which is used for the removal of acid gas.

Q(56). Which ONE of the following process sequences is used in the sugar industry ?

(A) Ca_2HPO_4 /Lime Treatment, Crystallization, Crushing

(B) Ca_2HPO_4 /Lime Treatment, Multiple stage evaporation, Crystallization

(C) Crushing, Crystallization, Ca_2HPO_4 /Lime Treatment

(D) Multiple stage evaporation, Crystallization, Ca_2HPO_4 /Lime Treatment

(GATE 2008)

Use Code: DEVENDRAPOONIA to get 10% off on Plus Subscription

Ans:-(B) Ca_2HPO_4 /Lime Treatment, Multiple stage evaporation, Crystallization

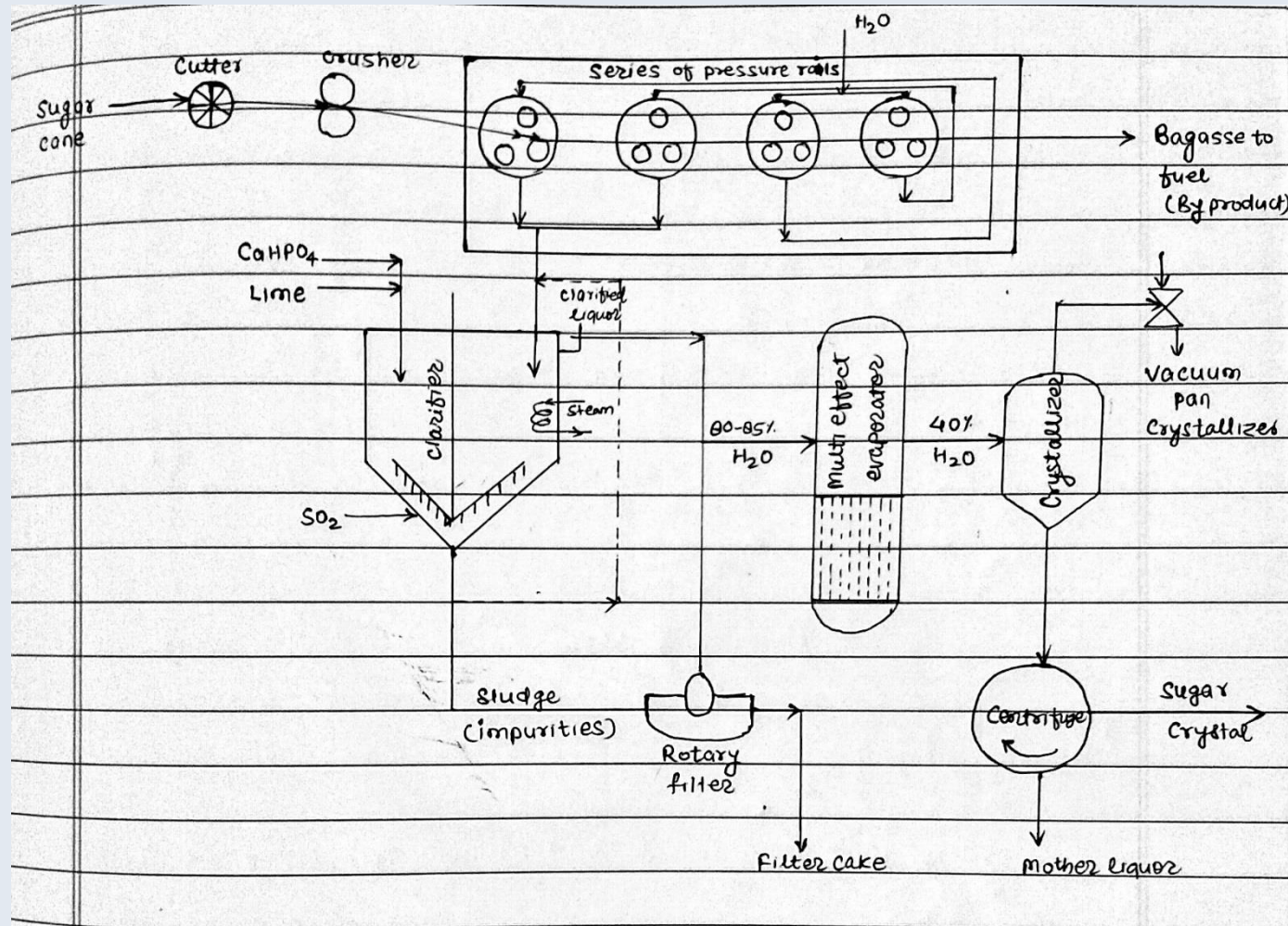

Use Code: DEVENDRAPOONIA to get 10% off on Plus Subscription

Q(57). Which of the following is desirable in gasoline but undesirable in kerosene ?

(A) Aromatics

(B) Mercaptans

(C) Naphthenic Acid

(D) Paraffins

(GATE 2007)

Use Code: DEVENDRAPOONIA to get 10% off on Plus Subscription

Ans:- (A) Aromatics

- Smoke comes out while burning the aromatic compounds which is not desirable in kerosene as it is used in household.

Q(58). In the Sulfite process for paper manufacture, the 'cooking liquor' is

- (A) Magnesium bisulfite and sulfur dioxide in acid medium
- (B) Magnesium sulfite and magnesium bicarbonate
- (C) Sodium sulfite and magnesium sulfite
- (D) Sodium sulfite, sodium bisulfite and sulfur dioxide

(GATE 2007)

- The kraft process (also known as kraft pulping or sulfate process) is a process for conversion of wood into wood pulp, which consists of almost pure cellulose fibers, the main component of paper.
- The kraft process entails treatment of wood chips with a hot mixture of water, sodium hydroxide (NaOH), and sodium sulfide (Na₂S), known as white liquor, that breaks the bonds that link lignin, hemicellulose, and cellulose. The technology entails several steps, both mechanical and chemical.
- It is the dominant method for producing paper.

Sulfate (Kraft) Pulping Process

- Most popularly used process.
- This is an alkaline process.
- Na_2SO_4 is added to the cooking liquor. So its common name is sulfate process.
- The presence of sodium sulfide makes bleaching of pulp easier and the paper produced has better strength.

Sulfite Process:-

- The sulfite process, the older and less used of the two primary chemical pulping processes, cooks wood chips in sulfurous acid combined with limestone to produce calcium bisulfite.
- The combination of sulfurous acid and calcium bisulfite dissolves the lignin in the wood and liberates the cellulose fibers.
- Sulfite pulp is soft and flexible, is moderately strong, and is used to supplement mechanical pulps (most typically in newsprint).

Ans:-(A) Magnesium bisulfite and sulfur dioxide in acid medium

- **Sulfite process**, sulfite also spelled **Sulphite**, chemical process for the manufacture of paper pulp.
- It employs an acid bisulfite solution to soften the wood material by removing the lignin from the cellulose.
- Sulfite cooking liquor used in the process consists of free sulfur dioxide obtained by the burning of sulfur or by the roasting of iron pyrites, dissolved in water at a concentration of four to eight percent, with from two to three percent in the form of bisulfite.

Q(59). Match the chemicals in Group 1 with their function in Group 2.

Group 1

P. styrene

Q. tert-dodecyl mercaptan

R. potassium pyrophosphate

Group 2

1) buffer

2) catalyst

3) modifier

4) monomer

Choose the correct set of combinations.

(A) P-1, Q-4, R-4

(C) P-4, Q-1, R-3

(B) P-4, Q-1, R-2

(D) P-4, Q-3, R-1

(GATE 2007)

Ans:- (D) P-4, Q-3, R-1

➤ Styrene monomer for polystyrene.

tert-dodecyl mercaptan:-

➤ It is used predominantly as a molecular weight regulator for polymerizations , in particular for radical polymerizations of vinylic monomers such as, for example, butadiene, styrene, carboxylated styrene, acrylic acid, acrylonitrile, acrylic ester , vinyl ether or their mixtures, especially in their emulsion polymerization in water.

potassium pyrophosphate:-

➤ Used as the components for formulation of clothing detergent, metal surface cleaning agent and bottle detergent as well as the additive used in various kinds of detergents

Use Code: DEVENDRAPOONIA to get 10% off on Plus Subscription

Q(60). Match the product in Group 1 with its application in the industries of Group 2

Group 1

P. lithium stearate

Q. magnesium stearate

R. aluminum sulphate

Group 2

1) cosmetics

2) paper

3) dry cleaning

4) greases

Choose the correct set of combinations.

(A) P-2, Q-3, R-1

(C) P-4, Q-2, R-3

(B) P-3, Q-4, R-2

(D) P-4, Q-1, R-2

(GATE 2007)

Ans:- (D) P-4, Q-1, R-2

Lithium stearate:-

- Lithium stearate is a chemical compound with the formula $\text{LiO}_2\text{C}(\text{CH}_2)_{16}\text{CH}_3$.
- It is formally classified as a soap (a salt of a fatty acid).
- Lithium stearate is a white soft solid, prepared by the reaction of lithium hydroxide and stearic acid.
- Lithium stearate and lithium 12-hydroxystearate are lithium soaps, and are components of lithium grease.

Use Code: DEVENDRAPOONIA to get 10% off on Plus Subscription

Magnesium stearate:-

- Magnesium stearate is the chemical compound with the formula $\text{Mg}(\text{C}_{18}\text{H}_{35}\text{O}_2)_2$.
- It is a soap, consisting of salt containing two equivalents of stearate (the anion of stearic acid) and one magnesium cation (Mg^{2+}).
- It is used as a component or lubricant in the production of pharmaceuticals and cosmetics.

Aluminum sulphate:-

- Aluminium sulfate is a chemical compound with the formula $\text{Al}_2(\text{SO}_4)_3$.
- It is soluble in water and is mainly used as a coagulating agent (promoting particle collision by neutralizing charge) in the purification of drinking water and waste water treatment plants, and also in paper manufacturing.

Use Code: DEVENDRAPOONIA to get 10% off on Plus Subscription

Q(61). Match the synthetic fibres in Group 1 with their classification in Group 2.

Group 1

P. Rayon

Q. Orlon

R. Dacron

Group 2

1) polyamide

2) polyester

3) cellulose

4) acrylic

Choose the correct set of combinations.

(A) P-2, Q-3, R-1

(C) P-3, Q-1, R-3

(B) P-3, Q-4, R-2

(D) P-3, Q-3, R-4

(GATE 2007)

Ans:- (B) P-3, Q-4, R-2

- Rayon - Cellulose
- Dacron (Terylene) - Polyester (PET)
- Orlon - Acrylic
- Acrylic fibers are synthetic fibers made from a polymer (polyacrylonitrile).
- DuPont created the first acrylic fibers in 1941 and trademarked them under the name Orlon.

Use Code: DEVENDRAPOONIA to get 10% off on Plus Subscription

Q(62). Match the Petrochemical derivative in Group 1 with the raw materials in Group 2.

Group 1

P. acrylonitrile

Q. ammonia

R. dodecene

Group 2

1) methane

2) ethane

3) ethylene

4) propylene

Choose the correct set of combinations.

(A) P-1, Q-2, R-1

(B) P-2, Q-1, R-2

(C) P-3, Q-4, R-3

(D) P-4, Q-1, R-3

(GATE 2007)

Use Code: DEVENDRAPOONIA to get 10% off on Plus Subscription

Ans:- (D) P-4, Q-1, R-3

Amoxidation (Acrylonitrile from propylene):-

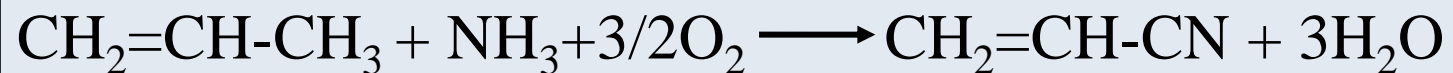

- Ammonia production from natural gas in methane is a major constituent.
- 1-Dodecene is an alkene with the formula $\text{C}_{10}\text{H}_{21}\text{CH}=\text{CH}_2$.
- it useful for a number of applications, especially for the production of detergents.
- The common route of production use a modified Ziegler ethylene chain growth technology.
- There are two main parts to this technology:- the ethylene chain growth and displacement.

Use Code: DEVENDRAPOONIA to get 10% off on Plus Subscription

Q(63). The Oxo reaction is used for converting

(A) alcohol to aldehyde

(B) paraffin to olefin

(C) olefin to aldehyde

(D) aldehyde to alcohol

(GATE 2006)

Ans:-(C) olefin to aldehyde

Propylene to Butanol (Oxo process):- Hydro formylation

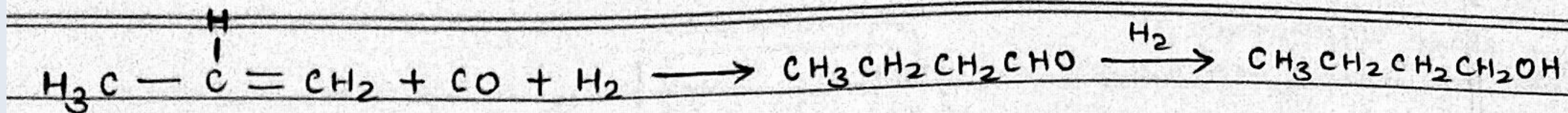

Q(64). In a fluid catalytic cracking unit, the nature of the reactions occurring in the reactor and the regenerator is

- (A) Reactor – Exothermic, Regenerator – Exothermic
- (B) Reactor – Exothermic, Regenerator – Endothermic
- (C) Reactor – Endothermic, Regenerator – Exothermic
- (D) Reactor – Endothermic, Regenerator – Endothermic

(GATE 2006)

Ans:-(C) Reactor – Endothermic, Regenerator – Exothermic

Use Code: DEVENDRAPOONIA to get 10% off on Plus Subscription

Process Flow Diagram of FCC:-

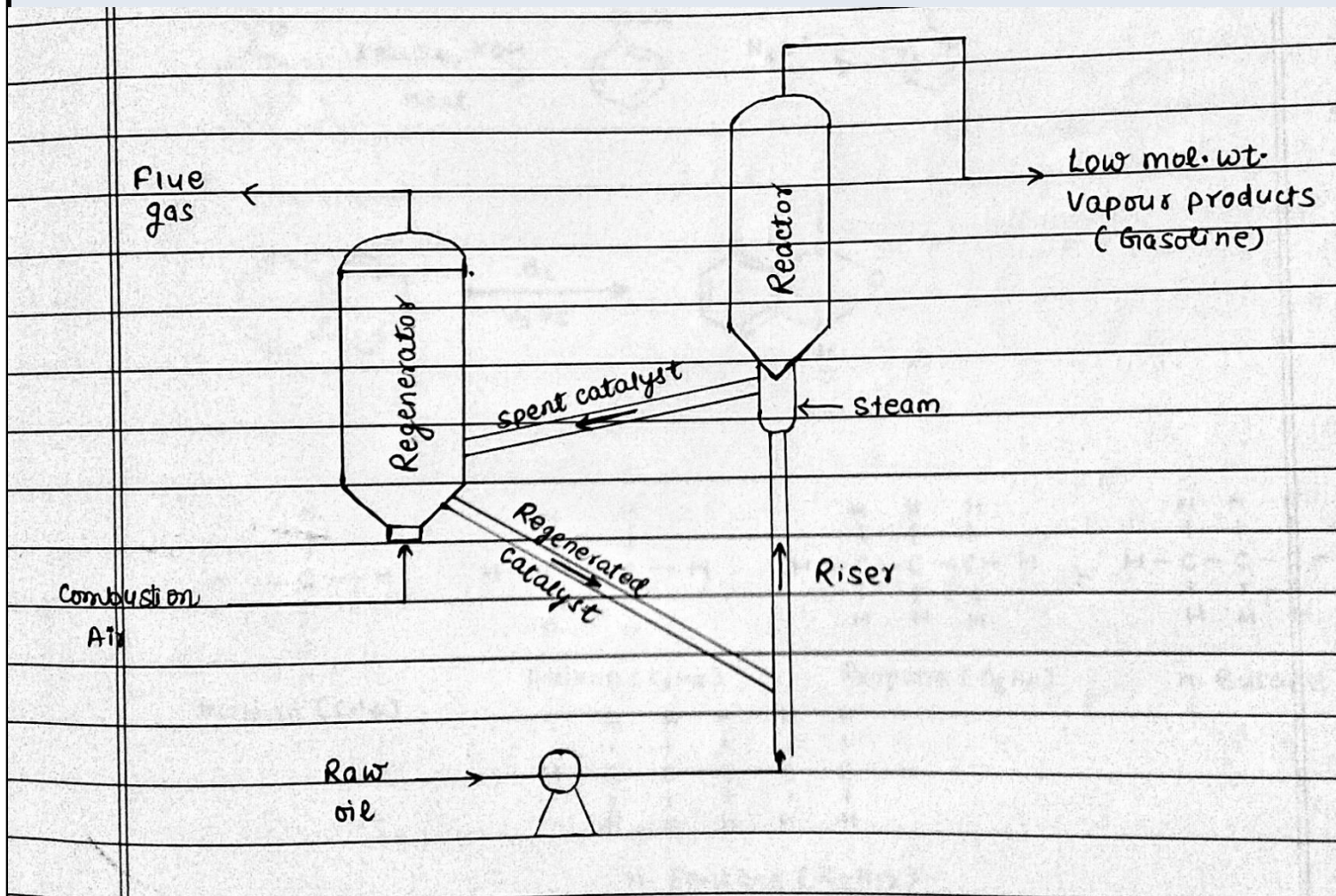

Key Points:-

- ❖ Regenerator- Exothermic Reaction
- ❖ Reactor- Endothermic Reaction
- ❖ Cracking reaction time – 2-4 sec

Q(65). Pair the following industrial processes with the catalysts used

- | | | |
|----|---|-------------|
| P. | Oxidation of o-xylene to phthalic anhydride | 1. V_2O_5 |
| Q. | Oxidation of ethanol to acetaldehyde | 2. Pd |
| R. | Oxidation of ammonia to oxides of nitrogen | 3. Ag |
| | | 4. Pt |

Choose the correct set of combinations.

- (A) P-1, Q-3, R-4
(B) P-2, Q-1, R-4
(C) P-4, Q-3, R-1
(D) P-1, Q-3, R-2

(GATE 2006)

Ans:-(A) P-1, Q-3, R-4

Oxidation of o-xylene to phthalic anhydride:-

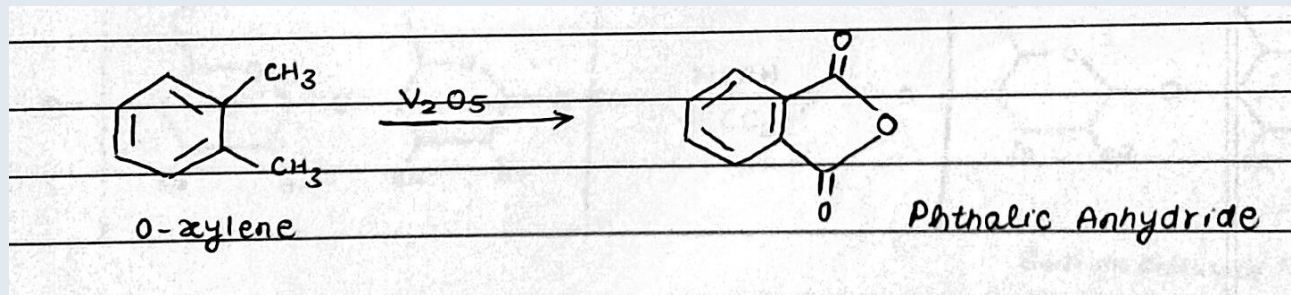

Oxidation of ethanol to acetaldehyde:-

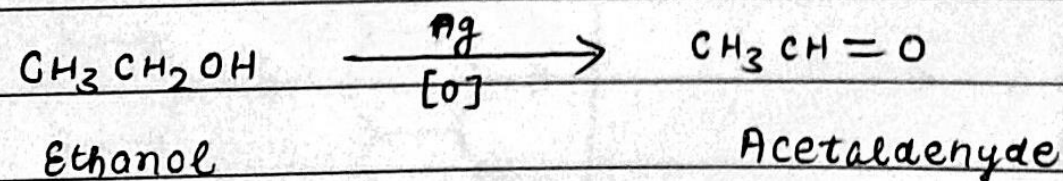

Oxidation of ammonia to oxides of nitrogen:-

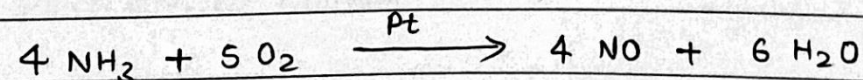

Q(66). Pair the following reactors with their products

P. Arc Furnace

Q. Fermenter

R. Hydrogenator

1. Citric acid

2. Calcium carbide

3. Saturated fats

4. Alum

Choose the correct set of combinations.

(A) P-4, Q-1, R-3

(B) P-2, Q-1, R-3

(C) P-4, Q-3, R-1

(D) P-2, Q-3, R-1

(GATE 2006)

Use Code: DEVENDRAPOONIA to get 10% off on Plus Subscription

Ans:-(B) P-2, Q-1, R-3

- Calcium carbide is produced industrially in an electric arc furnace from a mixture of lime and coke at approximately 2200 °C.



- Citric acid fermentation is a production process of citric acid.
- Hydrogenation of unsaturated hydrocarbons takes place in the hydrogenator.

Q(67). Pair the following polymers with their chain characteristics

- | | | |
|----|-------|--|
| P. | HDPE | 1. Very few branches |
| Q. | LDPE | 2. Short and regular branches |
| R. | LLDPE | 3. High branching with both short
and long chain branches |

Choose the correct set of combinations.

- (A) P-1, Q-2, R-3
- (B) P-2, Q-1, R-3
- (C) P-1, Q-3, R-2
- (D) P-2, Q-3, R-1

(GATE 2006)

Use Code: DEVENDRAPOONIA to get 10% off on Plus Subscription

Ans:-(B) P-2, Q-1, R-3

Polymer	Reactant	Branching	Types of polymerization	catalyst	Temperature (°C)	Pressure, (atm)
LDPE	Ethylene	Very few branches	Solution or bulk, tubular reactor, liquid phase	H ₂ O ₂	200-240	3500
HDPE	Ethylene	Short and regular branches	Suspension, stirred tank reactor, liquid phase	TiCl ₄	60-80	20-35
LLDPE	Ethylene & 1-butene	High branching with both short and long chain branches	Suspension, fluidized bed reactor, vapour phase	TiCl ₄	100	7-20

Use Code: DEVENDRAPOONIA to get 10% off on Plus Subscription

Q(68). Choose the most appropriate pairs from the following

- | | | | |
|----|--------------|----|----------------|
| P. | Nitration | 1. | Detergent |
| Q. | Sulphonation | 2. | Pulp and paper |
| R. | Carbonation | 3. | Explosives |
| | | 4. | Sugar |

Choose the correct set of combinations.

- (A) P-1, Q-2, R-4
- (B) P-3, Q-1, R-2
- (C) P-3, Q-1, R-4
- (D) P-3, Q-2, R-4

(GATE 2006)

Ans:-(C) P-3, Q-1, R-4

- Nitration is a general class of chemical process for the introduction of a nitro group into an organic chemical compound.
- Nitration reactions are notably used for the production of explosives, for example the conversion of guanidine to nitroguanidine and the conversion of toluene to trinitrotoluene.
- Sulfonation is an organic reaction in which a hydrogen atom on an alkyl or arene is replaced by a sulfonic acid functional group.
- Aryl sulfonic acids are used as detergents, dye, and drugs.
- In general two methods of clarification are available for the manufacture of white sugar, namely, Sulfitation process and Carbonation process.
- The carbonatation process is used in the production of sugar from sugar beets.

Use Code: DEVENDRAPOONIA to get 10% off on Plus Subscription

Q(69). Match the following

- | | | | |
|----|-------------------|----|-----------------|
| P. | Carbon disulphide | 1. | Nylon – 6 |
| Q. | Caprolactum | 2. | Nylon – 66 |
| R. | Gypsum | 3. | Phosphoric acid |
| | | 4. | Viscose rayon |

Choose the correct set of combinations.

- (A) P-4, Q-2, R-3 (B) P-2, Q-1, R-3
(C) P-3, Q-1, R-4 (D) P-4, Q-1, R-3

(GATE 2006)

Ans:-(D) P-4, Q-1, R-3

viscose rayon is a fiber of regenerated cellulose.

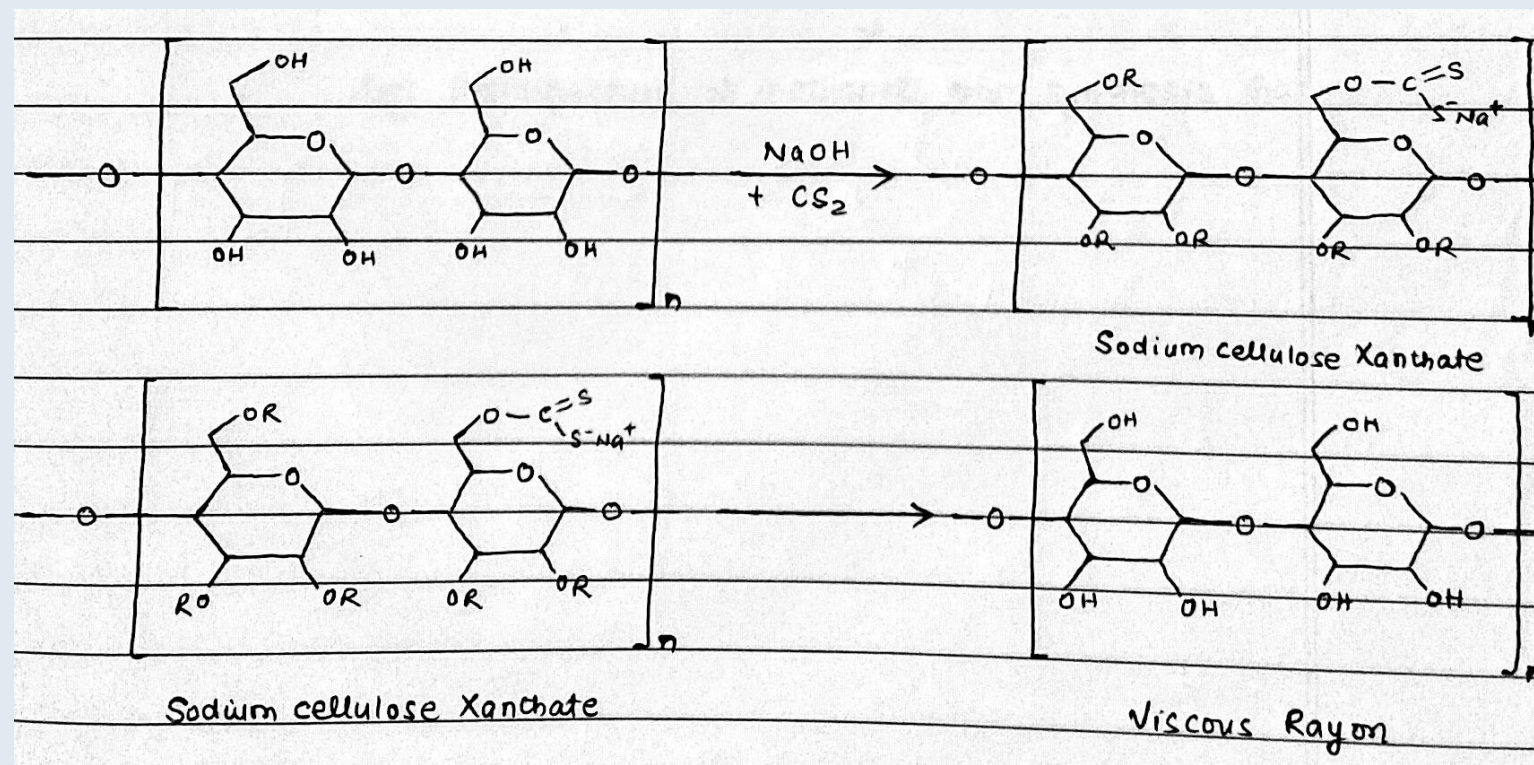
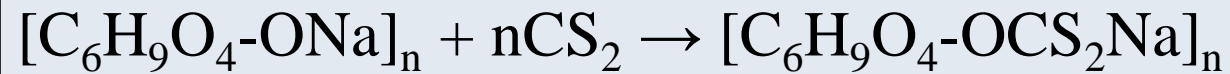

Use Code: DEVENDRAPOONIA to get 10% off on Plus Subscription

Nylon - 6:-

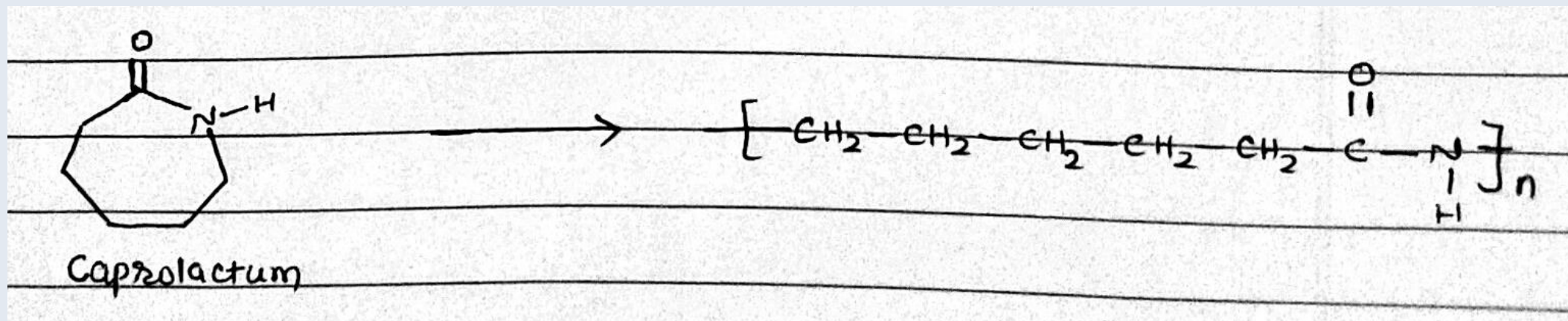

Gypsum:-

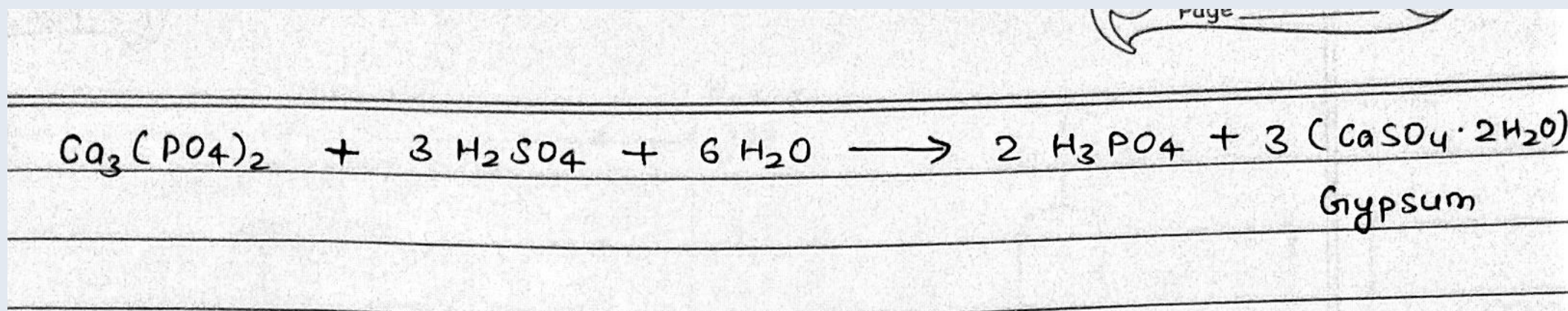

Q(70). Which of the following is NOT employed in the commercial production of linear polyvinyl chloride ?

- (A) Emulsion polymerization
- (B) Suspension polymerization
- (C) Addition polymerization
- (D) Condensation polymerization

(GATE 2005)

Ans:-(D) Condensation polymerization

- Because all other polymerization method can be employed for the production of linear polyvinyl chloride.

Q(71). Which of the following is a detergent ?

- (A) Benzene hexachloride
- (B) Cellulose nitrate
- (C) Polyvinyl chloride
- (D) Alkyl benzene sulfonate

(GATE 2005)

Ans:-(D) Alkyl benzene sulfonate

- A **detergent** is a surfactant or a mixture of surfactants with cleaning properties in dilute solutions.
- These substances are usually alkylbenzenesulfonates, a family of compounds that are similar to soap but are more soluble in hard water, because the polar sulfonate (of detergents) is less likely than the polar carboxylate (of soap) to bind to calcium and other ions found in hard water.

Q(72). The chief raw material for the commercial production of methanol is

- (A) Synthesis gas
- (B) Formaldehyde
- (C) Acetic acid
- (D) Ethanol

(GATE 2005)

Use Code: DEVENDRAPOONIA to get 10% off on Plus Subscription

Ans:-(A) Synthesis gas

The chief and major raw material for the production of methanol is synthesis gas.

Use Code: DEVENDRAPOONIA to get 10% off on Plus Subscription

Manufacture of Methanol from Synthesis Gas:-

Synthesis gas is $H_2 + CO$

When synthesis gas is subjected to high pressure and moderate temperature conditions, it converts to methanol.

Reactions

• Desired:

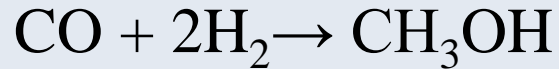

• Side reactions:

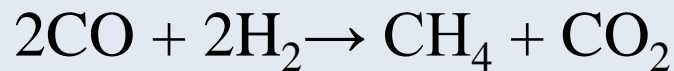
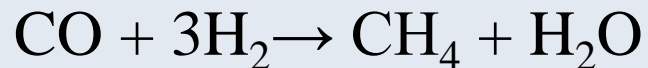

Potassium carbonate

(K_2CO_3) is an alkaline

salt which is used for

the removal of acid gas.

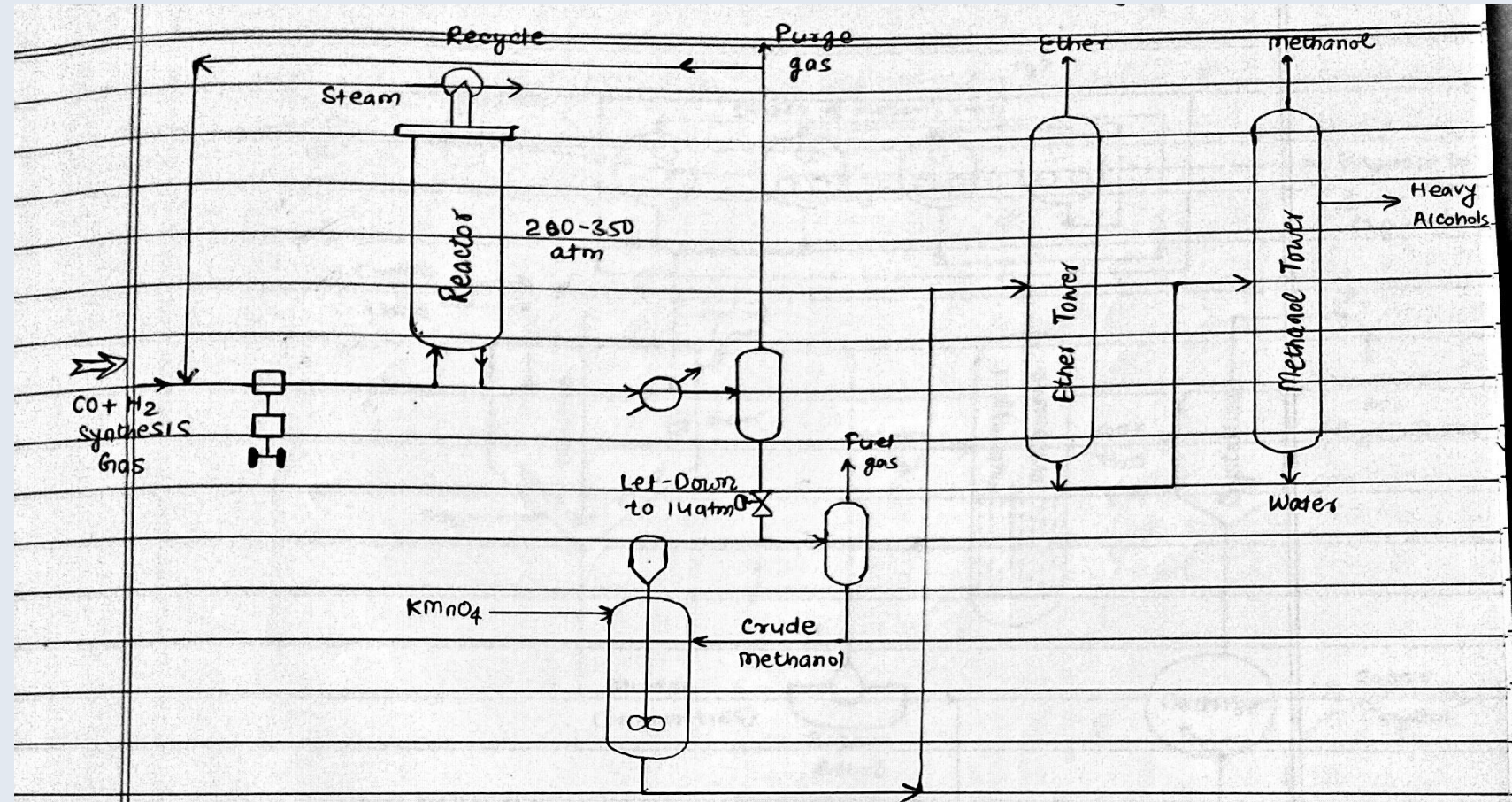

fig: Manufacture of methanol from synthesis Gas

Q(73). Match the raw materials in Group II with the products in Group I

Group I

Group II

Nylon – 66

(1) Chlorodifluoro methane

Terylene

(2) Dimethyl terephthalate and ethylene glycol

(3) Acetylene and hydrogen cyanide

(4) Hexamethylene diamine and adipic acid.

Choose the correct set of combinations.

(A) P-3, Q-4

(B) P-4, Q-3

(C) P-4, Q-2

(D) P-1, Q-2

(GATE 2005)

Ans:- (C) P-4, Q-2

S.No.	Polymer	Monomers
1.	Nylon 6,6	Adipic Acid + Hexamethylene diamine
2.	Terylene (PET)	Dimethyl terephthalate + Ethylene Glycol

Use Code: DEVENDRAPOONIA to get 10% off on Plus Subscription

Q(74). Match the product in Group I with the catalyst used for its production in Group II

Group I

(P) Nitric acid

(Q) Formaldehyde

Group II

(1) Silver oxide

(2) Raney nickel

(3) Activated carbon

(4) Platinum-Rhodium

Choose the correct set of combinations.

(A) P-1, Q-2

(B) P-2, Q-3

(C) P-3, Q-4

(D) P-4, Q-1

(GATE 2005)

Ans:- (D) P-4, Q-1

Nitric acid:- Platinum-Rhodium make up catalyst

Formaldehyde from methanol:- Silver oxide

Use Code: DEVENDRAPOONIA to get 10% off on Plus Subscription

Q(75). Match the products in Group I with the raw materials in Group II

Group I

Group II

(P) Caustic soda

(1) Ammonia and sulfuric acid

(Q) Soda ash

(2) Sodium carbonate and slaked lime

(3) Salt and limestone

(4) Salt and sulfuric acid

Choose the correct set of combinations.

(A) P-2, Q-3

(B) P-1, Q-2

(C) P-3, Q-4

(D) P-4, Q-1

(GATE 2005)

Ans:- (A) P-2, Q-3

Lime soda process:-



Solvay's ammonia soda process:-

➤ The Solvay process results in soda ash (Na_2CO_3) from brine (NaCl) and from limestone (CaCO_3).



Q(76). Match the feed in Group I with the process in Group II

(P) Gas oil

(Q) Residual crude

(1) Acetylene production

(2) Ethylene production

(3) Coking

(4) Cracking

Choose the correct set of combinations.

(A) P-3, Q-4

(B) P-4, Q-3

(C) P-2, Q-3

(D) P-1, Q-4

(GATE 2005)

Ans:-(B) P-4, Q-3

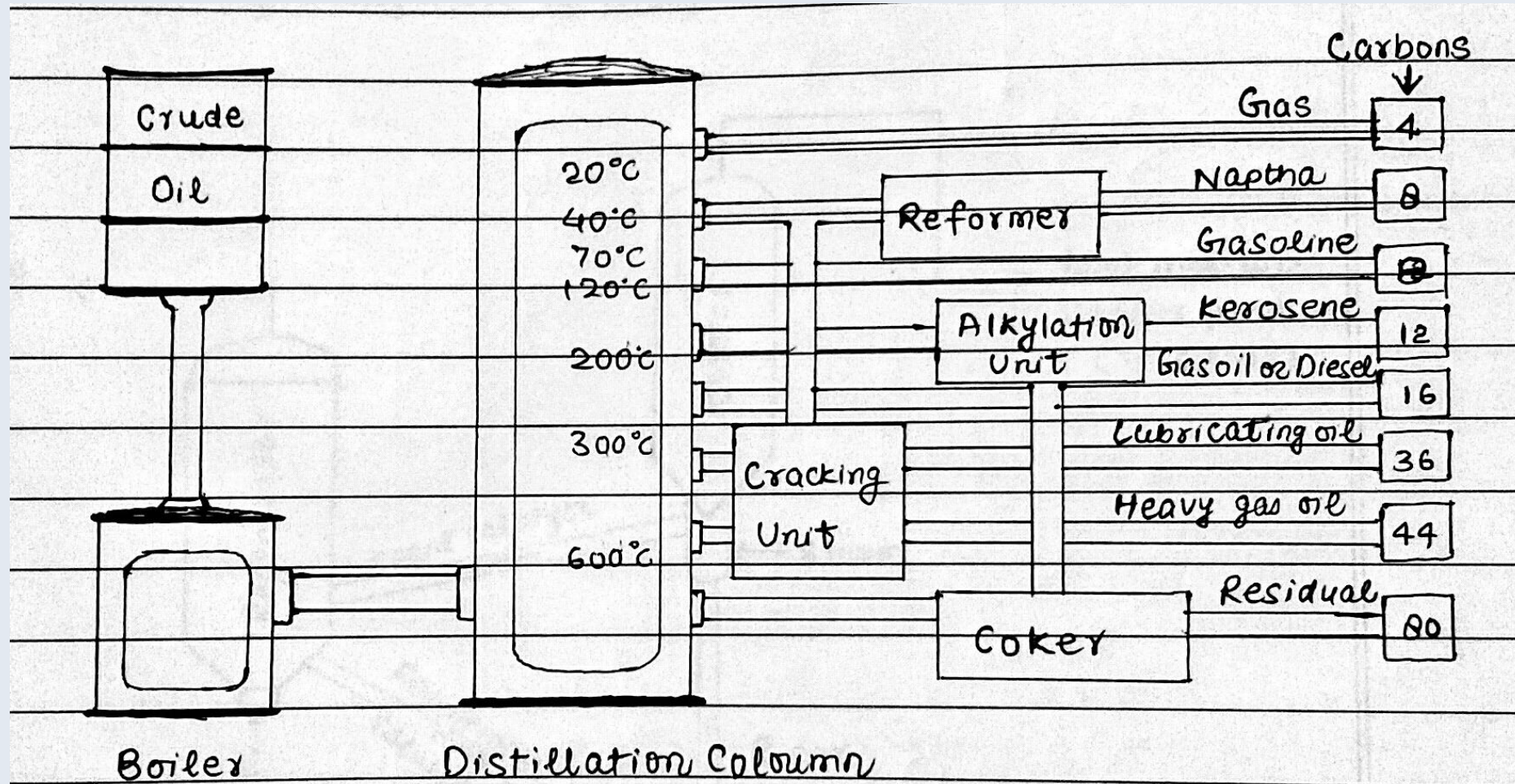

Q(77). Prilling tower is found in the flowsheet for the manufacture of

(A) Ammonia

(B) Super phosphate

(C) Urea

(D) Triple super phosphate

(GATE 2004)

Use Code: DEVENDRAPOONIA to get 10% off on Plus Subscription

Ans:- (C) Urea

Urea manufacture -

- Prilling tower used to convert fertilizer into the granular form.

Q(78). The proper arrangement of the petroleum fractions, in the order of their boiling points is

- (A) lubricating oils > diesel > petrol > LPG
- (B) lubricating oils > petrol > diesel > LPG
- (C) petrol > lubricating oils > diesel > LPG
- (D) petrol > diesel > LPG > lubricating oils

(GATE 2004)

Ans:-(A) lubricating oils > diesel > petrol > LPG

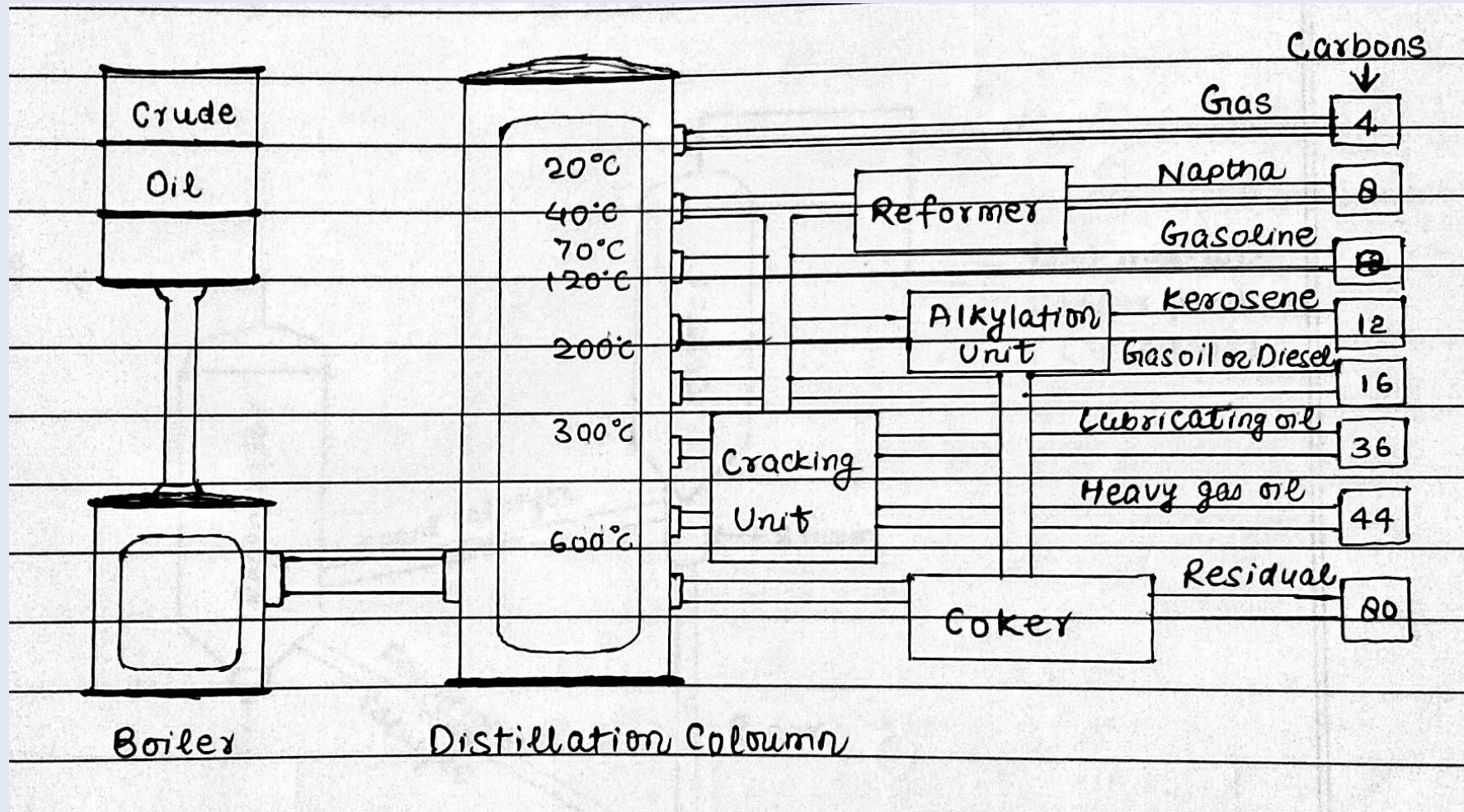

Use Code: DEVENDRAPOONIA to get 10% off on Plus Subscription

Q(79). Multiple effect evaporators are commonly used in the manufacture of

P. Paper

Q. Superphosphate

R. Sugar

S. Fats

(A) P and Q

(B) P and R

(C) P and S

(D) R and S

(GATE 2004)

Ans:-(B) P and R

Chemical recovery from black liquor:-

The black liquor (lignin-rich) produced from the Sulfate pulp production contains 95-98% of digested chemicals.

To reduce air and water pollution and to balance economy of operation, these chemicals should be removed before disposal.

Multi effect evaporator:-

- It is a series of single effect evaporators in series.
- Multi-effect evaporator and disc evaporator concentrate the black liquor from 15-18% solid to 60-65% solid.

Use Code: DEVENDRAPOONIA to get 10% off on Plus Subscription

Sugar Industry:-

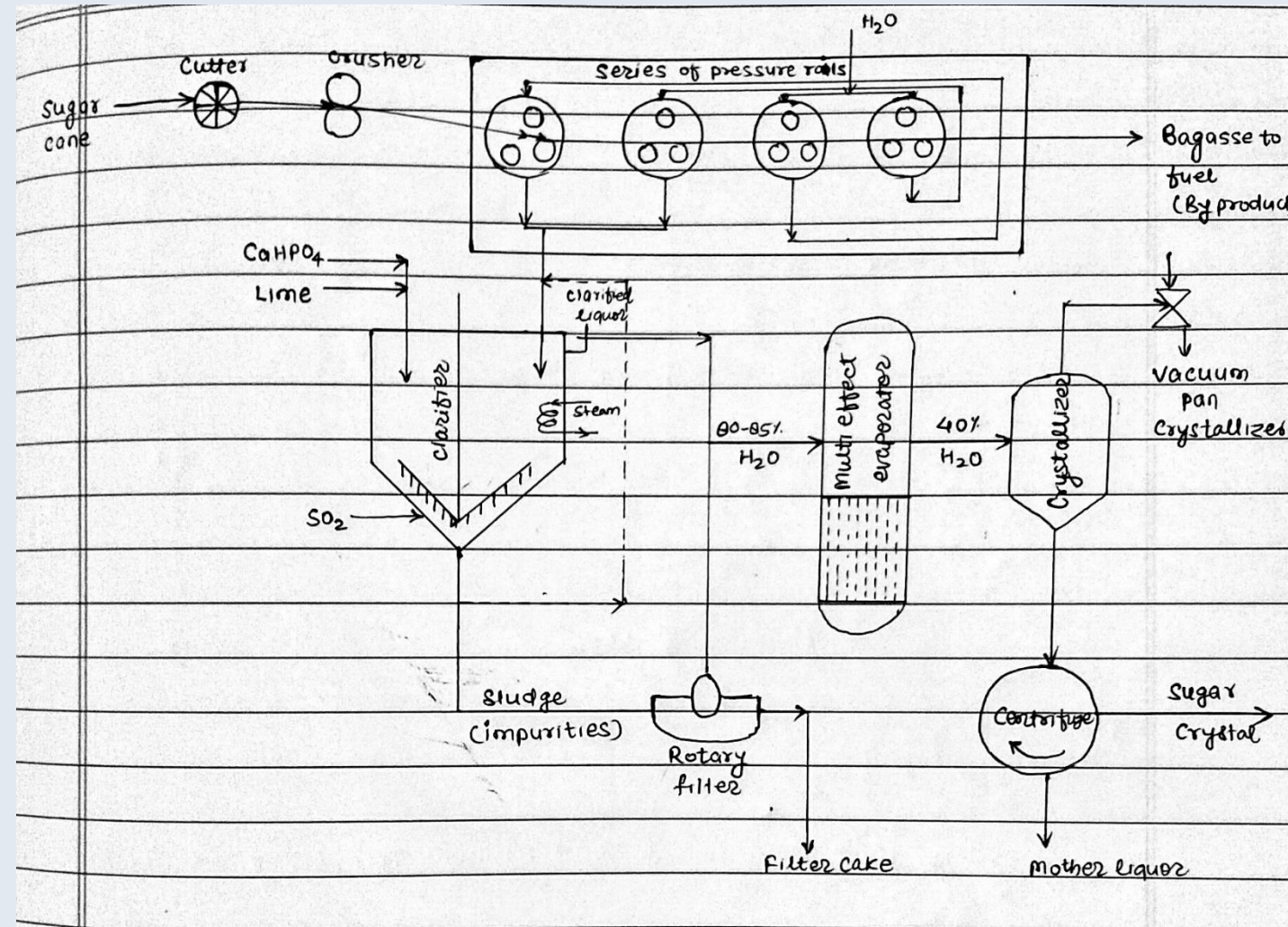

Use Code: DEVENDRAPOONIA to get 10% off on Plus Subscription

Q(80). Match the process in Group I with the product in Group II

Group I

P. DCDA process

Q. Mercury Cell

Group II

1. Sodium hydroxide

2. Sulfuric acid

3. Sodium carbonate

4. Nitric acid

(A) P-1, Q-4

(B) P-1, Q-2

(C) P-2, Q-3

(D) P-2, Q-1

(GATE 2004)

Ans:- (D) P-2, Q-1

Contact Process -

- Currently high concentrated sulphuric acid is produced.
- Vanadium pentoxide (V_2O_5) or Pt used as catalyst.
- More economical than lead chamber process.
- Can also produce SO_3 and oleum.

DCDA Process –

- Next steps to the Contact Process.
- SO_2 & SO_3 passed through absorption towers twice for further absorption & conversion of SO_2 to SO_3 & production of higher grade sulphuric acid.

Use Code: DEVENDRAPOONIA to get 10% off on Plus Subscription

Cells which are used for production of caustic soda are:-

1. Diaphragm cell
2. Mercury cathode cell
3. Membrane cell

Use Code: DEVENDRAPOONIA to get 10% off on Plus Subscription

Q(81). Match the product in Group I with the raw materials in Group II

Group I

Group II

P. Urea

1. Ammonia and carbon dioxide

Q. Polyester

2. Dimethyl terephthalate and ethylene glycol

3. Ammonia and carbon monoxide

4. Hexamethylene diamine and adipic acid.

(A) P-1, Q-4

(B) P-3, Q-2

(C) P-4, Q-3

(D) P-1, Q-2

(GATE 2004)

Ans:- (D) P-1, Q-2

Urea:-

Raw Materials:-

(i) Ammonia can be synthesized by Haber – Bosch

(ii) Carbon dioxide from synthesis gas

Reactions:-



Polyester or PET or Dacron or Terylene:-

Monomers:- Dimethyl terephthalate(DMT) and Ethylene glycol

Use Code: DEVENDRAPOONIA to get 10% off on Plus Subscription

Q(82). Match the product in Group I with the nature of the reaction in Group II

Group I

Group II

P. Polyethylene

1. Condensation polymerization

Q. Nylon

2. Addition polymerization

R. Polystyrene

(A) P-1, Q-1, R-2

(B) P-2, Q-2, R-1

(C) P-1, Q-2, R-1

(D) P-2, Q-1, R-2

(GATE 2004)

Ans:- (D) P-2, Q-1, R-2

S.No	Addition Polymerization	Condensation polymerization
1.	Monomer must have at least a double bond or triple bond	Monomer must have at least two similar or different functional group
2.	Has no by product	Produces by products such as water, ammonia, HCl
3.	Addition of monomer results in a polymer	Monomers condensed to give a polymer
4.	Produces thermoplastics	Produces thermosets
5.	Results in homochain polymers	Results in hetero-chain polymers
6.	Examples:-polyvinyl chloride (PVC), polyethylene, polypropylene, poly tetrafluoroethen or TEFLON, etc.	Examples:- Bakelite, nylon, polyester(PET) etc.

Use Code: DEVENDRAPOONIA to get 10% off on Plus Subscription

Q(83). Match the process in Group I with the catalyst used in Group II

Group I

P. Sulfuric acid manufacture

Q. Vegetable oil hydrogenation

Group II

1. Platinum

2. Vanadium pentoxide

3. Iron

4. Raney nickel

(A) P-3, Q-1

(B) P-2, Q-1

(C) P-2, Q-4

(D) P-4, Q-2

(GATE 2004)

Ans:- (C) P-2, Q-4

Sulphuric Acid Production (Contact Process) -

- Currently high concentrated sulphuric acid is produced.
- Vanadium pentoxide (V_2O_5) or Pt used as catalyst.
- More economical than lead chamber process.
- Can also produce SO_3 and oleum.

DCDA Process –

- Next steps to the Contact Process.
- SO_2 & SO_3 passed through absorption towers twice for further absorption & conversion of SO_2 to SO_3 & production of higher grade sulphuric acid.

Use Code: DEVENDRAPOONIA to get 10% off on Plus Subscription

Hydrogenation of oil:-

- Unsaturated fats can be made into saturated fats.
- A nickel catalyst is used to speed up the reaction.

Q(84). 'Nylon 66' is so named because

- (A) the average degree of polymerization of the polymer is 1966
- (B) the number of carbon atoms between two nitrogen atoms are 6
- (C) the number of nitrogen atoms between two carbon atoms are 6
- (D) the polymer was first synthesized in 1966.

(GATE 2003)

Ans:- (B) the number of carbon atoms between two nitrogen atoms are 6

- Nylon 6,6 is so named because six carbon atom in each monomer (Hexamethylene diamine and adipic acid) unit.

Q(85). The catalytic converter for conversion of SO_2 to SO_3 by contact process should have a feed with SO_2 content between

- (A) 2 – 5 %
- (B) 7 – 10%
- (C) 12 – 15%
- (D) 20 – 25%

(GATE 2003)

Ans:- (B) 7 – 10%

- Analysis is based on Le Chatelier's Principle.
- The operating lines plotted on the equilibrium curve
- The angle of the operating line depends on the SO_2 concentration in the gas.
- The higher the SO_2 concentration, the lower the angle of the operating line.
- The higher the SO_2 concentration, the fewer inerts (N_2 , CO_2) are present to absorb the heat that is generated so the temperature rises more and equilibrium considerations result in lower conversions.
- With low SO_2 strength gases, less heat is generated by the reaction to SO_3 and there are more inerts present so the temperature rise is less in an adiabatic reaction. The advantage of a weak gas is that higher conversions can be obtained.

Use Code: DEVENDRAPOONIA to get 10% off on Plus Subscription

Q(86). The composition of fresh feed to the high temperature high pressure urea autoclave is

- (A) Excess liquid ammonia and liquefied CO₂
- (B) Excess liquid ammonia and compressed CO₂ gas
- (C) Liquid ammonia and excess compressed CO₂
- (D) Compressed NH₃ gas and excess compressed CO₂

(GATE 2003)

Ans:-(B) Excess liquid ammonia and compressed CO₂ gas

Urea:-

Raw Materials:-

- (i) Excess liquid ammonia can be synthesized by Haber – Bosch
- (ii) Compressed Carbon dioxide from synthesis gas

Reactions:-



Q(87). Identify the group in which all the polymers mentioned can be used to make fibers

- (A) Butadiene copolymers, Polyamides, Urea aldehydes
- (B) Cellulose derivatives, Polyisoprene, Polyethylene
- (C) Cellulose derivatives, Polyamides, Polyurethanes
- (D) Polypropylenes, Polyvinyl-chloride, Silicones

(GATE 2003)

Ans:-(C) Cellulose derivatives, Polyamides, Polyurethanes

Cellulose derivatives:-

- A cellulose derivative of important fiber and film properties, cellulose triacetate, is obtained by reacting cellulose with glacial acetic acid in presence of acetic anhydride and traces of sulfuric acid in refluxing methylene chloride.

Use Code: DEVENDRAPOONIA to get 10% off on Plus Subscription

Polyamides:-

- Aliphatic polyamides-Nylons
- Aromatic polyamides-Aramids
- Examples:- Nylon 66, Nylon 6

Polyurethane fibers:-

- Known as- Spandex
- Polyurethane fiber is manufactured from glycol and diisocyanate as raw material.

End Uses:-

➤ **(1) For clothing:-**

Used as a Part of Foundations such as Brassieres, Girdles, Corsets, Sweaters, Underwear, Pantyhose, Socks, Swimsuits, Shirts Slacks, etc.

➤ **(2) For other uses:-**

Bandages, Supporters, Paper Diapers, etc.

Q(88). The preferred reacting system for oxidation of o-xylene to phthalic anhydride is

- (A) jacketed liquid phase CSTR
- (B) multitubular reactor with cooling
- (C) jacketed steam heated multitubular reactor
- (D) multistage multitubular reactor with interstage cooling

(GATE 2003)

Ans:- (B) multitubular reactor with cooling

- Basic raw material is Naphthalene or o-xylene.
- multitubular reactor is used for o-xylene to phthalic anhydride.
- fluidized bed reactor is demonstrated for naphthalene to phthalic anhydride.
- Naphthalene + O₂ → Phthalic anhydride + H₂O + CO₂
- O-Xylene + O₂ → Phthalic anhydride + Water.
- Catalyst: Vanadium pentoxide.
- Reaction is highly exothermic.

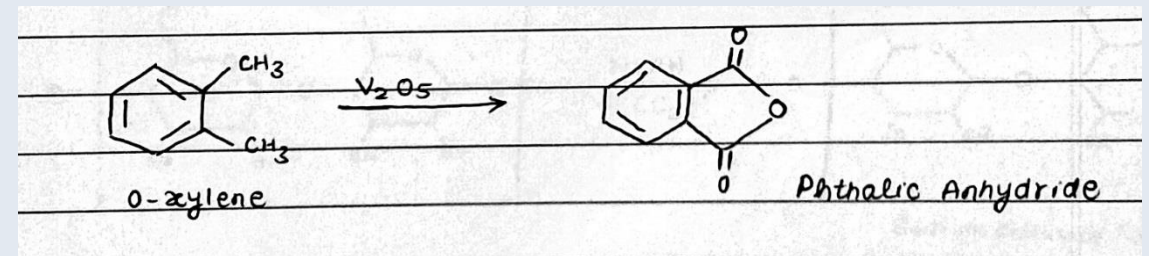
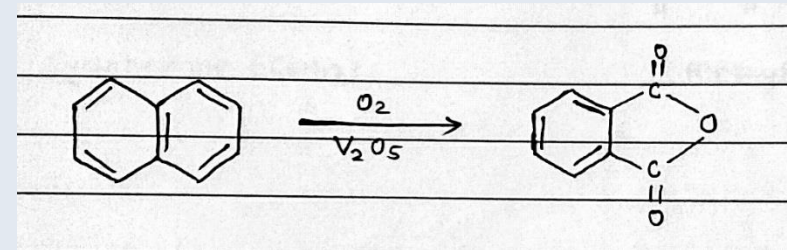

Q(89). match the items in Group 1 with the items in Group 2

Group – 1

P. Calcium ammonium nitrate

Q. $\text{CaCl}_2 - \text{NaCl}$ liquor

Group – 2

1. Fertilizer industry

2. Paper and Pulp industry

3. Soda ash industry

(A) P – 1, Q – 3

(B) P – 1, Q – 2

(C) P – 3, Q – 1

(D) P – 2, Q – 3

(GATE 2003)

Use Code: DEVENDRAPOONIA to get 10% off on Plus Subscription

Ans:- (A) P – 1, Q – 3

Calcium ammonium nitrate:-

- Calcium ammonium nitrate (CAN) is a nitrogenous fertilizer produced by treating ammonium nitrate solution with powdered limestone.

Raw materials:-

- Ammonia by Haber – Bosch
- Nitric acid synthesized from Ostwald's process
- Lime stone is obtained from mineral calcite or aragonite

Reaction:-



Use Code: DEVENDRAPOONIA to get 10% off on Plus Subscription

Solvay's ammonia soda process:-

- The Solvay process results in soda ash (Na_2CO_3) from brine (NaCl) and from limestone (CaCO_3).



Major engineering problem:-

Waste disposal -

Large quantities of CaCl_2 - NaCl liquor is generated during the process. The uses of these liquor is to be find out or dispose it as waste.

Q(90). match the items in Group 1 with the items in Group 2

Group – 1

P. Black liquor

Q. Activated silica alumina

R. Press mud

(A) P – 1, R – 2

(B) P – 2, Q – 1

(C) Q – 1, R – 2

(D) Q – 2, R – 1

Group – 2

1. Petroleum refining

2. Sugar factory

(GATE 2003)

Ans:- (C) Q – 1, R – 2

Chemical recovery from black liquor:-

- The black liquor (lignin-rich) produced from the Sulfate pulp production contains 95-98% of digested chemicals.
- To reduce air and water pollution and to balance economy of operation, these chemicals should be removed before disposal.
- In chemical recovery process, black liquor is concentrated, burned and limed.

Pressmud:-

- It is an industrial waste available from the sugar mills.
- For every 100 tonnes of sugarcane crushed about 3 tones of pressmud cake is left behind as by-product.

Claus Process (*sulfur recovery unit (SRU)*):-

- Catalyst - Activated silica alumina
- The Claus process is the most significant gas desulfurizing process, recovering elemental sulfur from gaseous hydrogen sulfide.
- Hydrogen sulfide produced in the hydro-desulfurization of refinery naphthas and other petroleum oils, is converted to sulfur in Claus plants.
- The reaction consists in two steps:

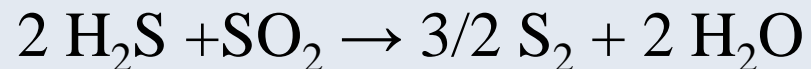
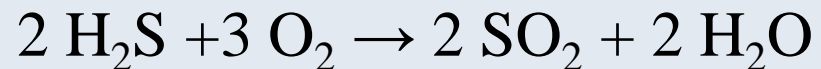

Q(91). In a refinery, petroleum crude is fractionated into gas fraction, light ends, intermediate distillates, heavy distillates, residues and by products. The group of products including gas oil, diesel oil and heavy fuel oil belongs to the fraction.

(A) heavy distillates

(B) intermediate distillates

(C) light ends

(D) residues

(GATE 2003)

Ans:- (A) heavy distillates

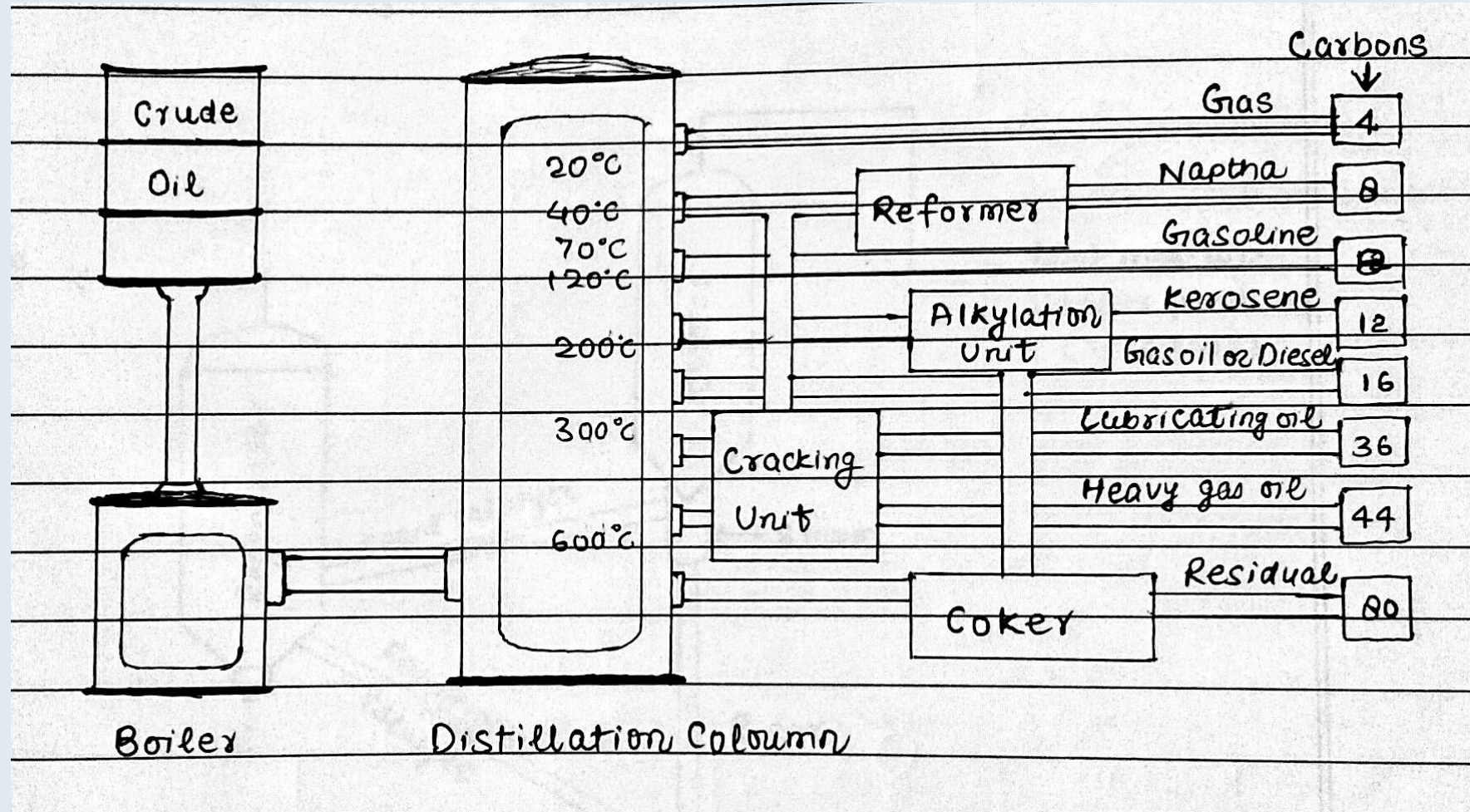

Q(92). The order of preference for feedstock to a catalytic reformer is

(A) catalytic naphtha → coking naphtha → virgin naphtha

(B) Coking naphtha → virgin naphtha → catalytic naphtha

(C) virgin naphtha → catalytic naphtha → coking naphtha

(D) virgin naphtha → coking naphtha → catalytic naphtha

(GATE 2003)

Ans:- (D) virgin naphtha → coking naphtha → catalytic naphtha

- The naphtha is a mixture of very many different hydrocarbon compounds.
- It contains paraffin, naphthene (cyclic paraffins) and aromatic hydrocarbons ranging from those containing 4 carbon atoms to those containing about 10 or 11 carbon atoms.
- The naphthas derived from the distillation of crude oils are referred to as "straight-run" naphthas.
- The naphtha from the crude oil distillation is often further distilled to produce a "light" naphtha containing most (but not all) of the hydrocarbons with 6 or fewer carbon atoms and a "heavy" naphtha containing most (but not all) of the hydrocarbons with more than 6 carbon atoms.

Use Code: DEVENDRAPOONIA to get 10% off on Plus Subscription

It is the straight-run heavy naphtha that is usually processed in a catalytic reformer because

- (1) The light naphtha has molecules with 6 or fewer carbon atoms which, when reformed, tend to crack into butane and lower molecular weight hydrocarbons which are not useful as high-octane gasoline blending components.
- (2) The molecules with 6 carbon atoms tend to form aromatics which is undesirable because governmental environmental regulations in a number of countries limit the amount of aromatics (most particularly benzene) that gasoline may contain.

Use Code: DEVENDRAPOONIA to get 10% off on Plus Subscription

Apart from straight-run naphthas, the following are other streams usually fed to reformer units, which have a boiling range similar to that of typical catalytic reforming feed, and come from a visbreaking unit, coking unit, hydrocracking/HDT unit, or FCC unit. They generally contain high amounts of sulfur, nitrogen, and olefins, which are mostly aromatic and difficult to hydrotreat.

- **Visbreaker naphtha**, which requires severe hydrotreating in order to prepare a proper reformer feedstock. That is why visbreaker naphtha is usually limited to small percentages of the feed reformer.
- **Coker naphtha**, whose properties are more or less the same as those of visbreaker naphtha but whose amount available from refineries is higher.
- **Hydrocracked and hydrotreated naphtha**, which is produced by hydro-cracking and hydrotreating of heavier petroleum fractions. This naphtha is a suitable reformer feedstock since it is rich in naphthenes.
- **FCC naphtha**, which is produced by catalytic cracking of gas oils. Although not being a viable feed to catalytic reforming, some refineries use it, particularly the 75 to 150 ° C fraction.

Use Code: DEVENDRAPOONIA to get 10% off on Plus Subscription

Q(93). From among the following, choose one that is not an exothermic process

(A) Methanol synthesis

(B) Catalytic cracking

(C) Ammonia synthesis

(D) Oxidation of sulphur

(GATE 2002)

Use Code: DEVENDRAPOONIA to get 10% off on Plus Subscription

Ans:- (B) Catalytic cracking

Process Flow Diagram of FCC:-

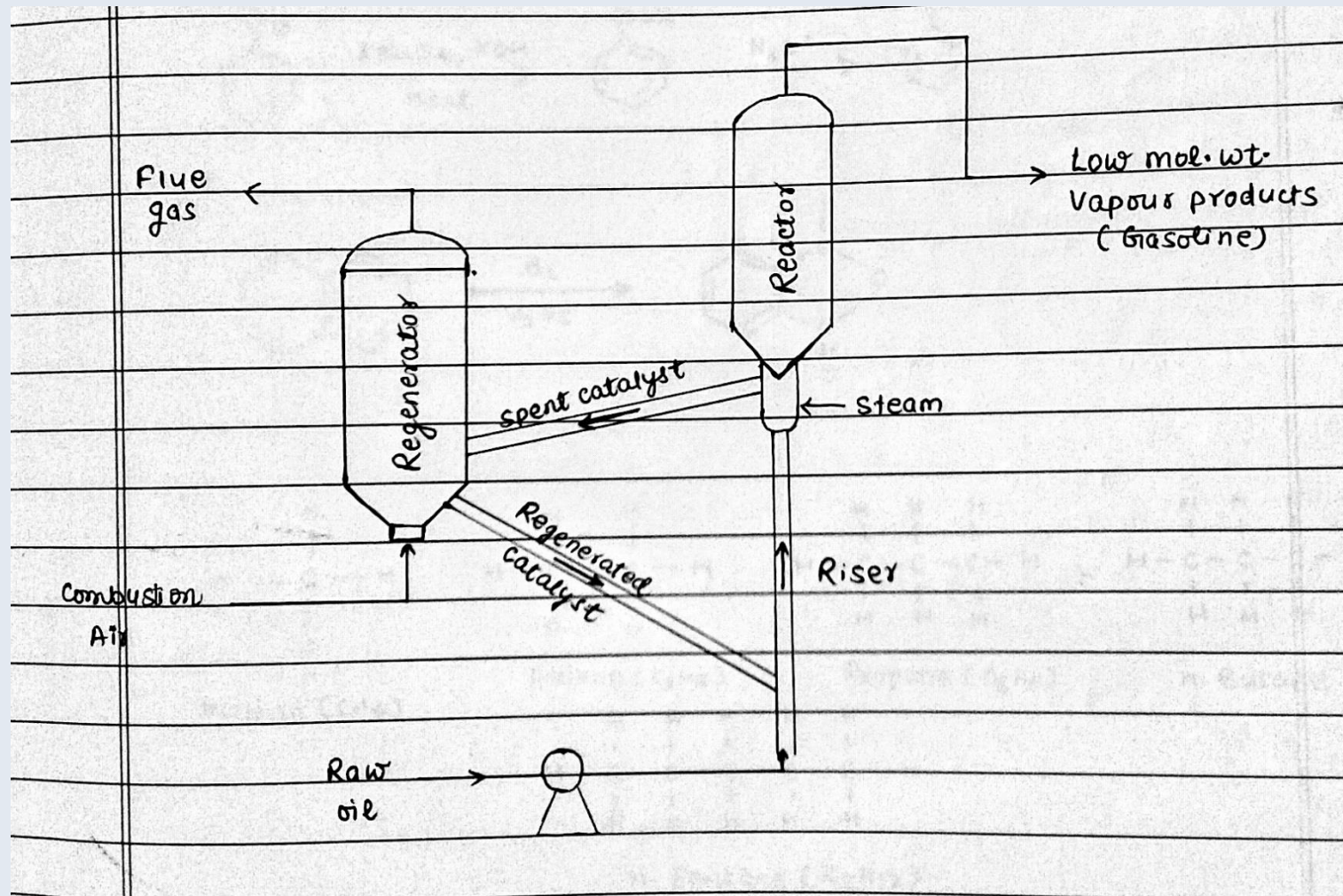

Key Points:-

- ❖ Regenerator- Exothermic Reaction
- ❖ Reactor- Endothermic Reaction
- ❖ Cracking reaction time – 2-4 sec

Q(94). The commonly used solvent in supercritical extraction is

(A) Methyl ethyl ketone

(B) Water

(C) Carbon tetrachloride

(D) Carbon dioxide

(GATE 2002)

Use Code: DEVENDRAPOONIA to get 10% off on Plus Subscription

Ans:- (D) Carbon dioxide

Supercritical Fluid Extraction (SFE):-

- It is the process of separating one component (the extractant) from another (the matrix) using supercritical fluids as the extracting solvent.
- Carbon dioxide (CO₂) is the most used supercritical fluid.
- Extraction conditions for supercritical carbon dioxide are above the critical temperature of 31 °C and critical pressure of 74 bar.

Use Code: DEVENDRAPOONIA to get 10% off on Plus Subscription

Q(95). The average boiling point of aviation turbine fuel is closest to that of

(A) Lubricating oils (B) LPG (C) Diesel (D) Kerosene (GATE 2002)

Use Code: DEVENDRAPOONIA to get 10% off on Plus Subscription

Ans:- (D) Kerosene

Column	Fraction	Temperature	Carbon range	Uses
Atmospheric column	Fuel Gases	>40	C ₁ -C ₂	Fuel
	LPG		C ₃ -C ₄	Domestic fuel
	Straight run gasoline/	20-90	C ₆ -C ₁₀	Gasoline pool
	Naphtha (Medium and heavy)	130-180	C ₆ -C ₁₀	Catalytic reforming and aromatic plant feed stock Steam cracker, synthesis gas manufacture
	Kerosene	150-270	C ₁₁ -C ₁₂	Aviation turbine fuel, Domestic fuel, LAB feed stock (paraffin source)
	Light gas oil	230-320	C ₁₃ -C ₁₇	High speed diesel component
Heavy gas oil	320-380	C ₁₈ -C ₂₅	High speed diesel component	
Vacuum column	Light vacuum gas oil	370-425	C ₁₈ -C ₂₅	Feed to FCC /HCU
	Heavy vacuum gas oil	425-550	C ₂₆ -C ₃₈	Feed to FCC /HCU
	Vacuum slop	550-560		RFCCU feed
	Vacuum Residue	>560	>C ₃₈	Bitumen/ Visbreaker feed

Use Code: DEVENDRAPOONIA to get 10% off on Plus Subscription

Q(96). In the manufacture of sulphuric acid from elemental sulphur, the following sequence of major operations is followed

- (A) Furnace → converter → absorber
- (B) Furnace → evaporator → absorber
- (C) Furnace → converter → evaporator
- (D) Converter → furnace → absorber

(GATE 2002)

Ans:- (A) Furnace → converter → absorber

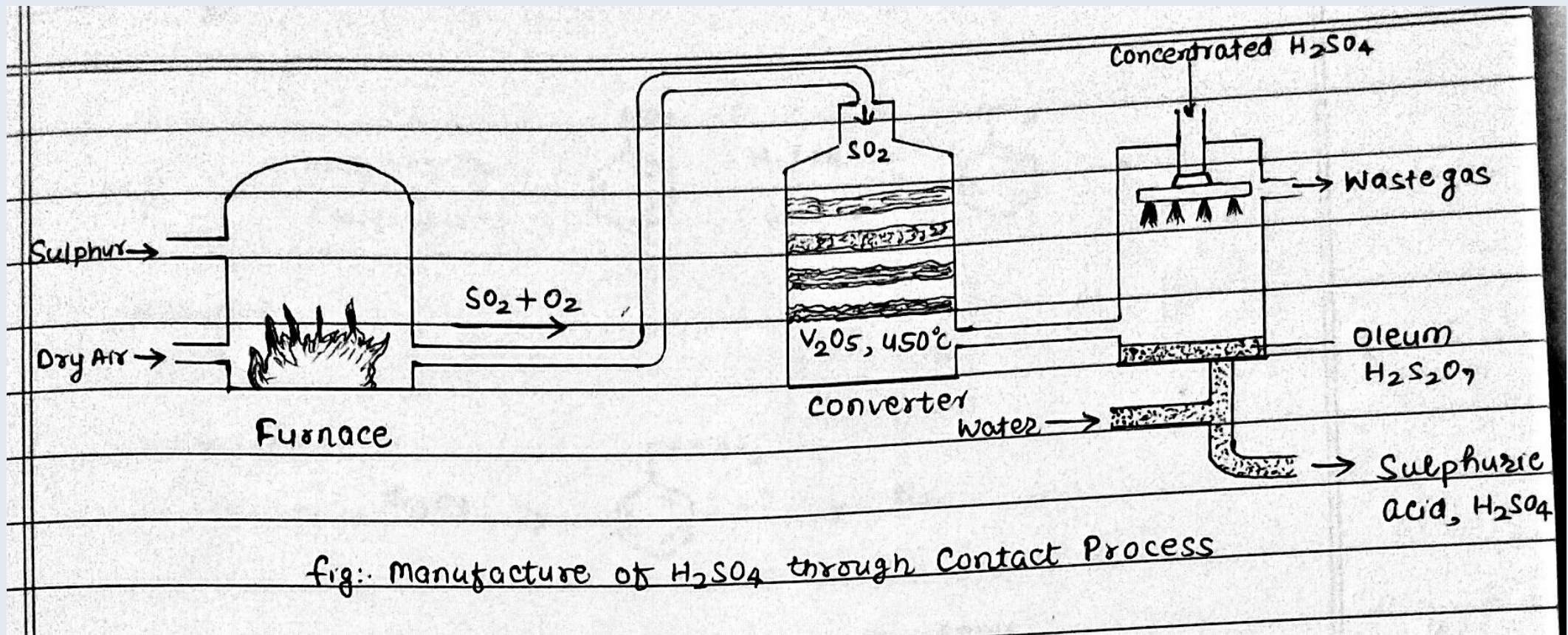

Q(97). Consider the production of ammonia from methane and air as raw materials. The catalysts used are ---(a)--- for steam reforming of methane and ---(b)---for ammonia synthesis

- (A) (a) Ni/Al₂O₃ (b) Cu-ZnO/Al₂O₃
- (B) (a) Fe/Al₂O₃ (b) Cu-ZnO/Al₂O₃
- (C) (a) Ni /Al₂O₃ (b) Fe /Al₂O₃
- (D) (a) Fe /Al₂O₃ (b) Ni /Al₂O₃

(GATE 2002)

Ans:- (C) (a) Ni /Al₂O₃ (b) Fe /Al₂O₃

- Steam reforming is a method for producing hydrogen, carbon monoxide, or other useful products from hydrocarbon fuels such as natural gas.
- The steam methane reformer is widely used in industry to make hydrogen.

steam methane reforming (SMR):-

- It is the most common method of producing commercial bulk hydrogen at about 95% of the world production
- Hydrogen is used in the industrial synthesis of ammonia and other chemicals.
- At high temperatures (700 – 1100 °C) and in the presence of a metal-based catalyst (**nickel**), steam reacts with methane to yield carbon monoxide and hydrogen.
- $\text{CH}_4 + \text{H}_2\text{O} \rightleftharpoons \text{CO} + 3 \text{H}_2$

Use Code: DEVENDRAPOONIA to get 10% off on Plus Subscription

Haber Process:-

- The Haber Process combines nitrogen from the air with hydrogen derived mainly from natural gas (methane) into ammonia.



- The reaction is reversible and the production of ammonia is exothermic.
- The catalyst is actually slightly more complicated than pure **iron**. It has potassium hydroxide added to it as a promoter - a substance that increases its efficiency.

Q(98). Sodium hydroxide is produced in an electrolytic cell by the electrolysis of brine.

i. Write the reactions at the anode, cathode and the overall reactions in a Mercury Cell and Diaphragm Cell.

ii. Mercury cells produce more concentrated NaOH solution compared to membrane cells.

However, membrane cells are widely replacing the mercury cells in the chloralkali industry.

Give two major reasons for this trend.

iii. Define the decomposition efficiency of an electrolytic cell used for producing NaOH.

iv. If 1.158×10^5 Coulombs is used to deposit 1 gram equivalent of NaOH, what is the current efficiency of the cell ?

(GATE 2001)

Ans:-(i).

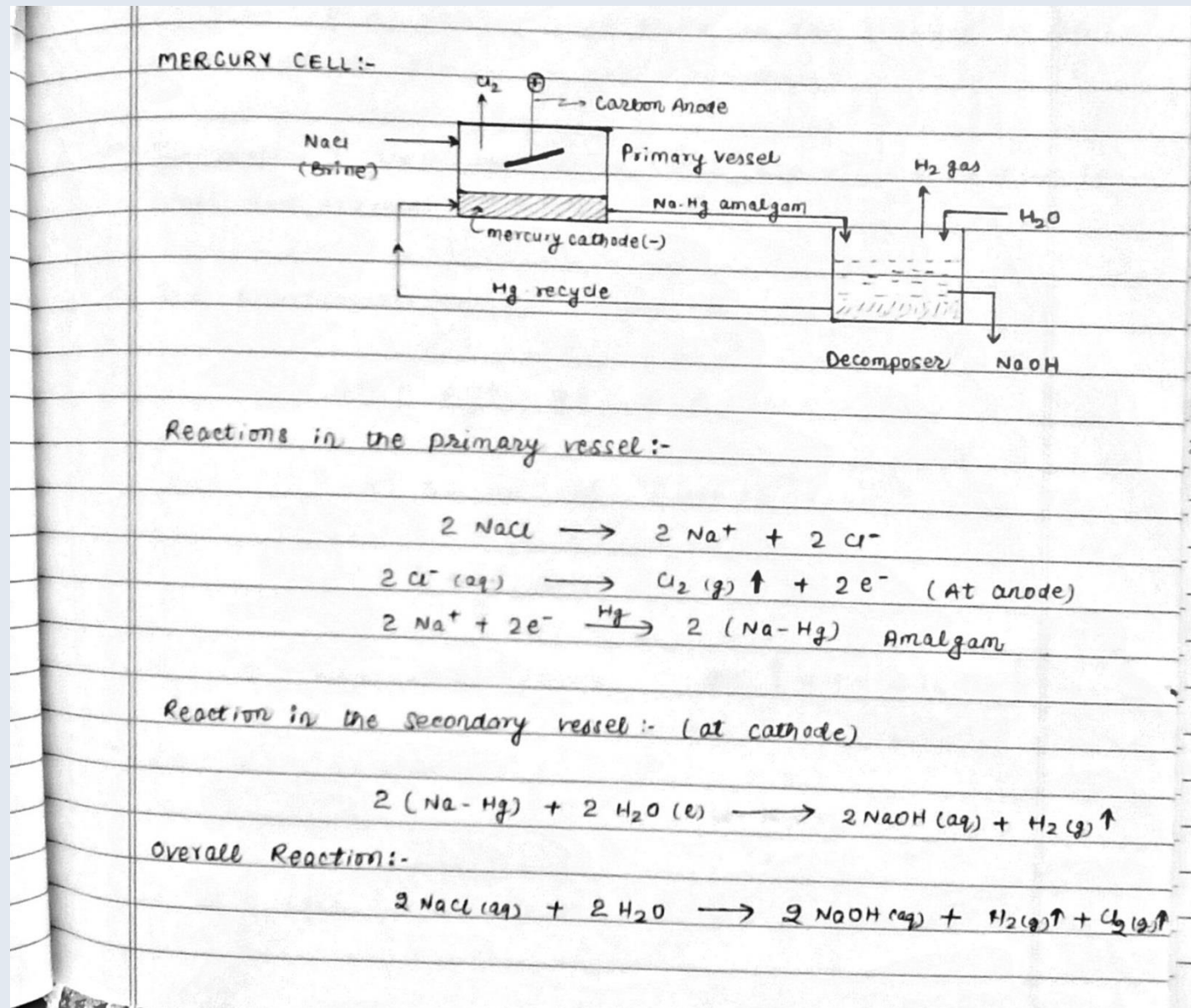

Ans:-(i).

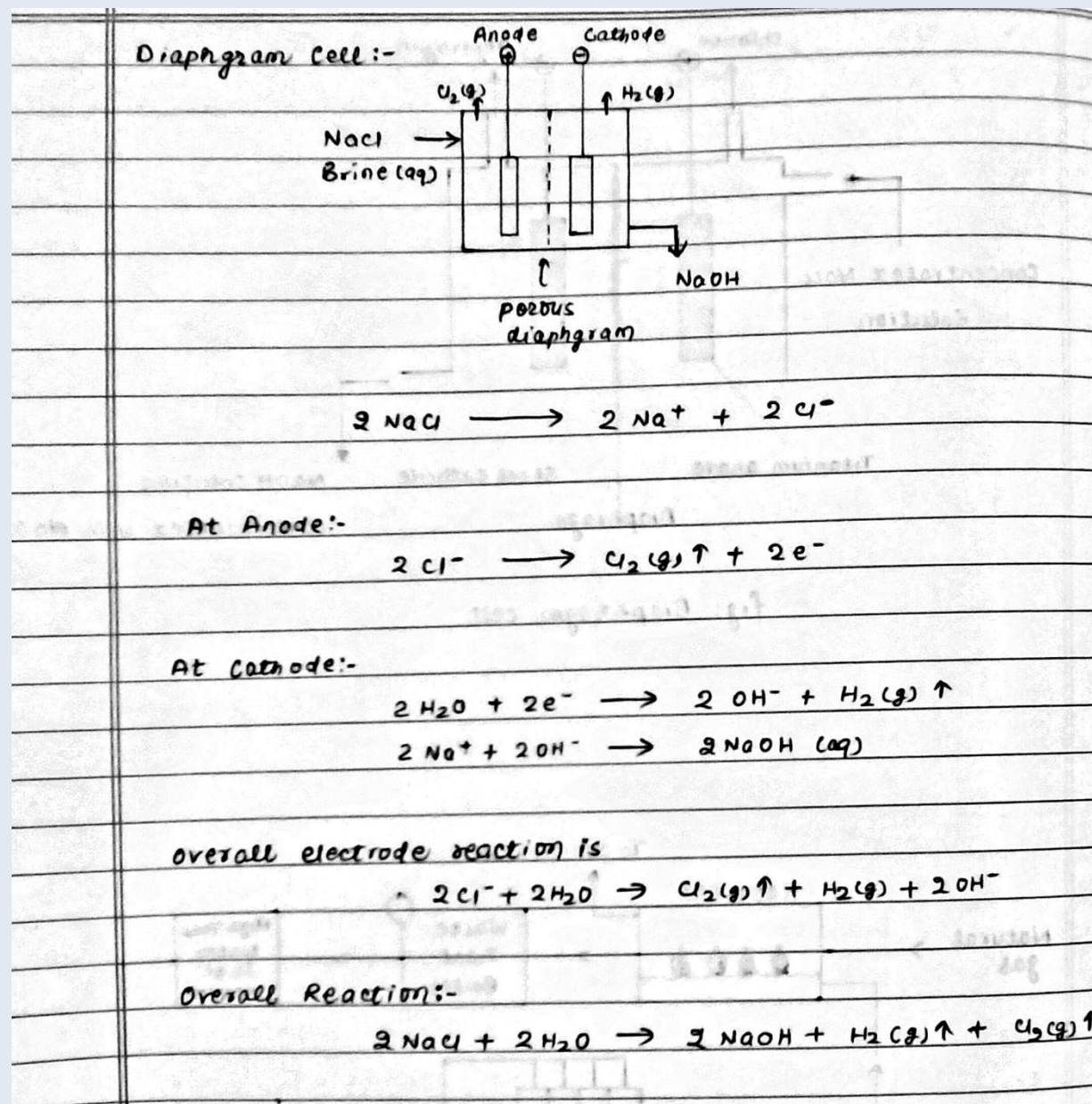

Ans:-

(ii). Membrane cells are replacing mercury cells because

- NaOH produced by membrane cell is very pure while NaOH produced by mercury cell is less pure and is contaminated with mercury.
- Membrane cell is more energy efficient and is cheaper to operate.

(iii). Decomposition efficiency of an electrolytic cell:-

$$\eta_D = (\text{gram equivalents of NaOH produced} / \text{gram equivalents of NaCl charged}) \times 100$$

Ans:- (iv).

Faraday's Laws of electrolysis:-

One gram-equivalent weight of matter is deposited or dissolved on each electrode for 96485 C (Columb) of electricity charge passed through the electrolyte.

Current efficiency = $\frac{\text{(Theoretical amount of current reqd. to produce 1 gm-eq of NaOH)}}{\text{(Actual amount of current reqd. to produce 1 gm-eq NaOH)}}$

$$= \frac{96500 \text{ C}}{1.158 \times 10^5} \times 100 = 83.33 \%$$

Q(99). One of the steps during refining of cane sugar consists of addition of hydrated lime to the sugar syrup followed by carbonation of the resulting solution. The purpose of this step is to

- (A) Adjust the pH of the syrup
- (B) Reduce the viscosity of the syrup
- (C) Remove the coloring matter from the syrup
- (D) Improve the rate of crystallization of sugar

(GATE 2001)

Ans:- (A) Adjust the pH of the syrup

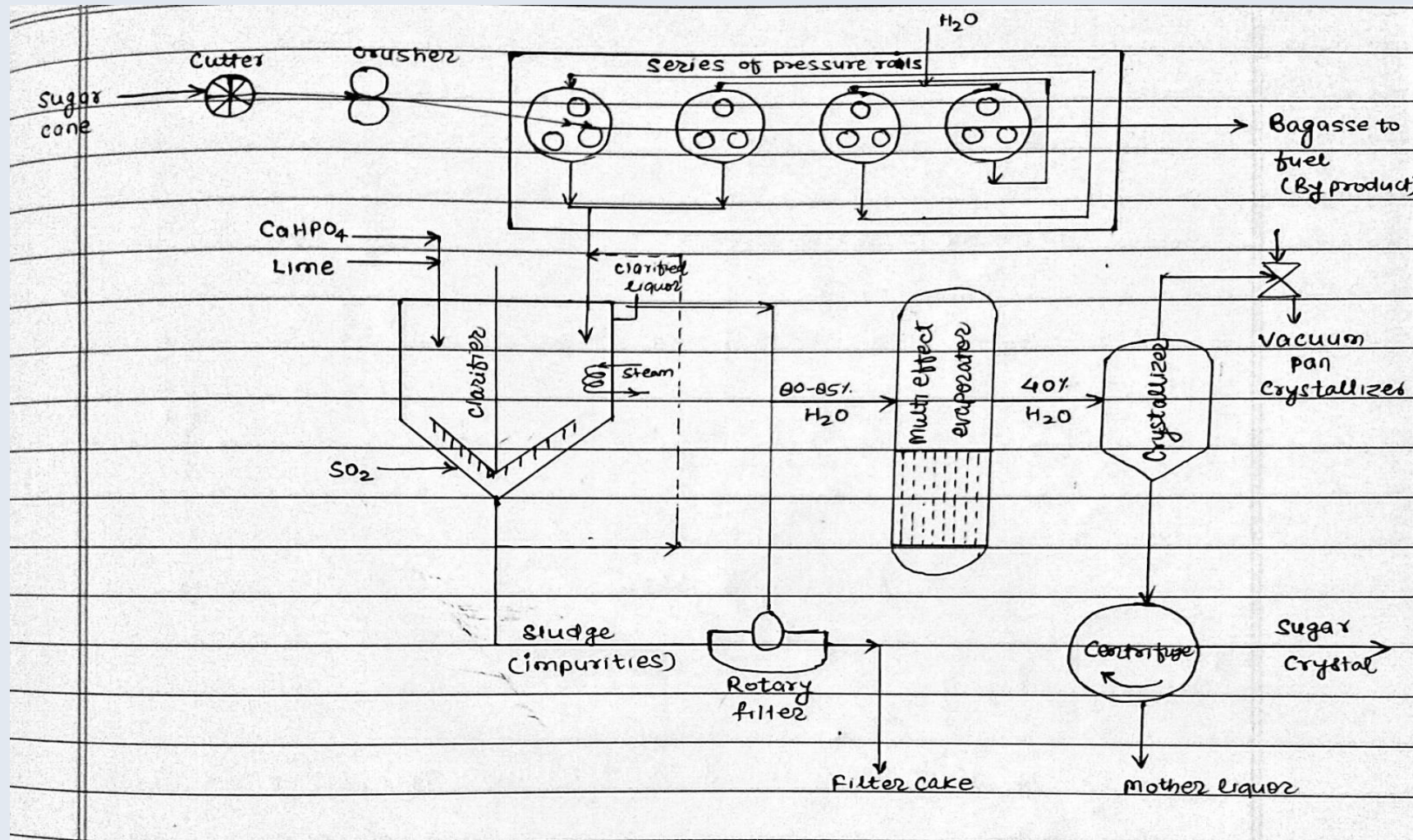

Use Code: DEVENDRAPOONIA to get 10% off on Plus Subscription

Clarifier

- In general two methods of clarification are available for the manufacture of white sugar, namely, Sulfitation process and Carbonation process.
- The juice now comes to thickener.
- To precipitate the colloids, calcium phosphate(CaHPO_4) is added followed by milk of lime.
- The milk of lime used has 9 to 10% strength and about 400mg CaO/litre alkalinity.
- **Apart from maintaining p^{H} about 7, SO_2 gas also acts as a bleaching agent.**
- Phosphoric acid or CO_2 can also be substituted as acidifying agent depending upon the type of extracted juice.
- At the bottom of clarifier, mud (impurities) are settled and drained.
- Steam is used to slightly heat the juice.

Use Code: DEVENDRAPOONIA to get 10% off on Plus Subscription

Q(100). Styrene is produced from ethyl-benzene by the process of

(A) Dehydrogenation

(B) Oxidation

(C) Alkylation

(D) Dehydration

(GATE 2001)

Ans:- (A) Dehydrogenation

Dehydrogenation (Styrene from ethylbenzene):-

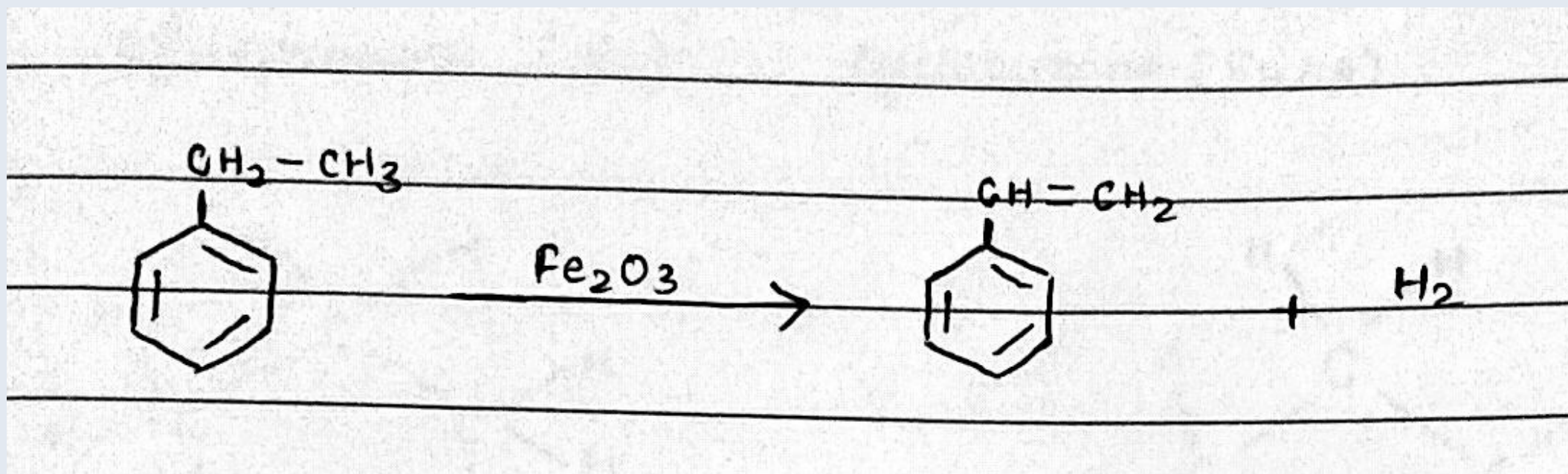

**Q(101). In the fluid catalytic cracker (FCC), the cracking reaction is ---(a)--
- and the regeneration is ---(b)---**

- (A) (a) Exothermic (b) Endothermic
- (B) (a) Exothermic (b) Exothermic
- (C) (a) Endothermic (b) Endothermic
- (D) (a) Endothermic (b) Exothermic

(GATE 2001)

Ans:- (D) (a) Endothermic (b) Exothermic

Process Flow Diagram of FCC:-

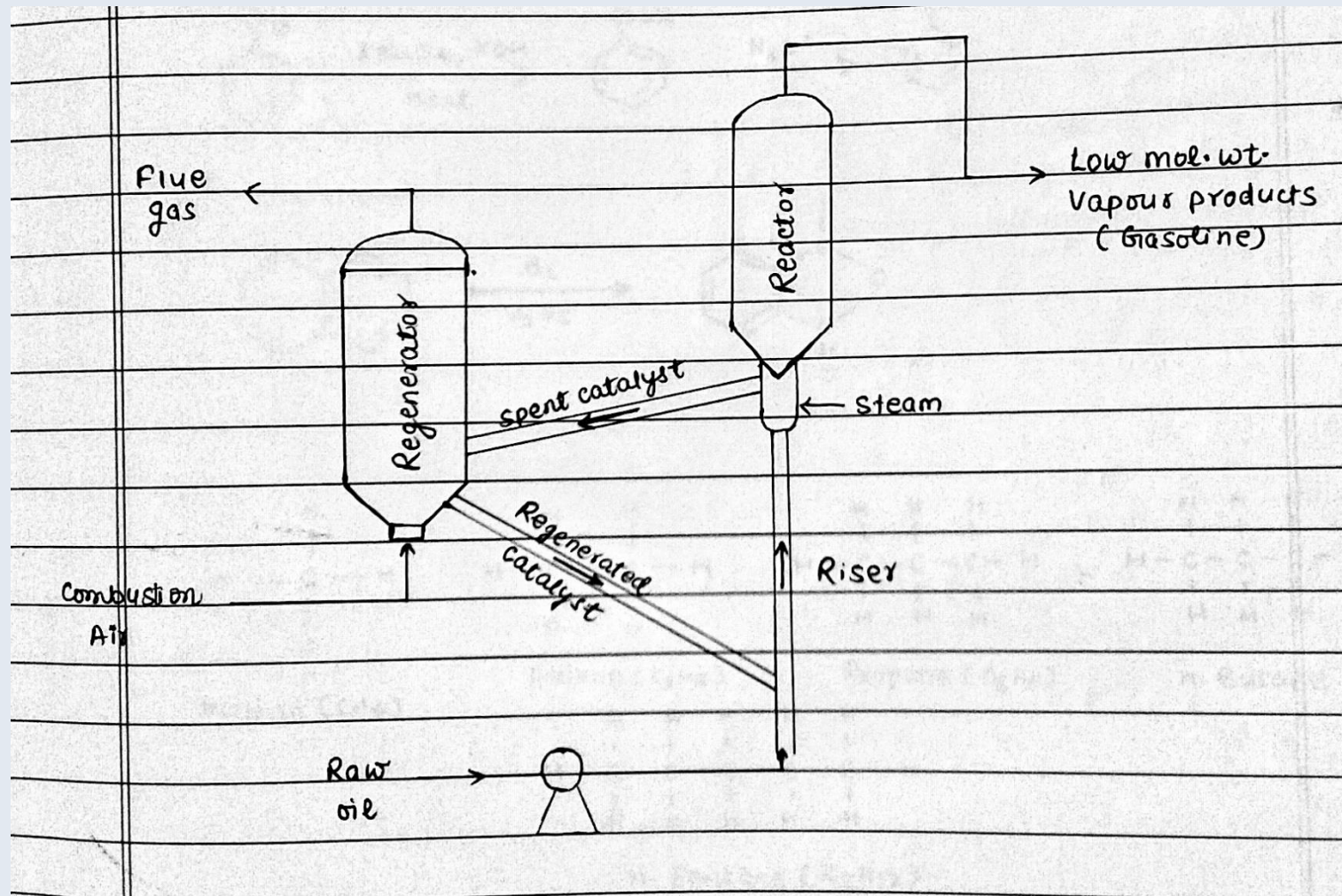

Key Points:-

- ❖ Regenerator- Exothermic Reaction
- ❖ Reactor- Endothermic Reaction
- ❖ Cracking reaction time – 2-4 sec

Q(102). In the converter of the contact process for the manufacture of H_2SO_4 , the equilibrium conversion of SO_2 -----(a)----- with increase in the temperature and -----(b)----- with increase in the mole ratio of SO_2 to air.

- (A) (a) increases (b) decreases
- (B) (a) decreases (b) increases
- (C) (a) increases (b) increases
- (D) (a) decreases (b) decreases

(GATE 2001)

Ans:- (B) (a) decreases (b) increases

- Analysis is based on Le Chatelier's Principle.
- The operating lines plotted on the equilibrium curve
- Equilibrium conversion of SO_2 decreases with increase in the temperature
- Equilibrium conversion of SO_2 increases with increase in the mole ratio of SO_2 to air.

Use Code: DEVENDRAPOONIA to get 10% off on Plus Subscription

Q(103). For the hydrogenation of oils, ----(a)---- is commonly used as catalyst, and ----(b)----is a catalyst poison.

(A) (a) Platinum (b) Sulfur

(B) (a) Palladium (b) Oxygen

(C) (a) Nickel (b) Sulfur

(D) (a) Nickel (b) Oxygen

(GATE 2001)

Ans:- (C) (a) Nickel (b) Sulfur

Hydrogenation of oil:-

- Unsaturated fats can be made into saturated fats.
- A **nickel** catalyst is used to speed up the reaction.
- **Sulfur** act as a catalyst poison.

Q(104). Using appropriate structural formulae, write the equations representing the following reactions in the stoichiometrically balanced form.

- A. Dehydrogenation of isopropanol to acetone
- B. Hydro formylation of propylene to butyraldehyde
- C. Nitration of toluene to o- nitrotoluene
- D. Oxidation of cumene to cumene hydroperoxide using oxygen
- E. Isomerization of n-butane to isobutene

(GATE 2001)

Ans:-

A. Dehydrogenation of isopropanol to acetone

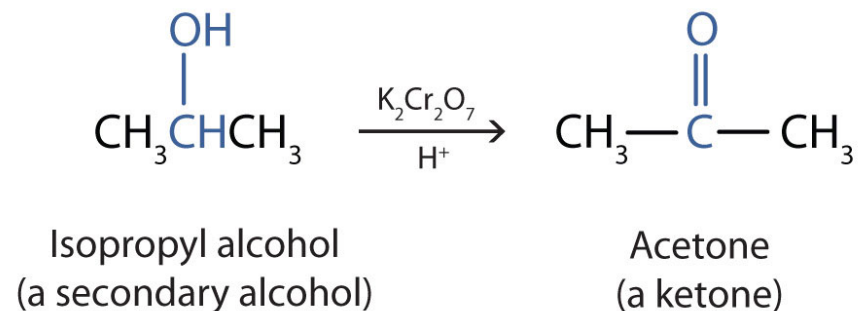

B. Hydro formylation of propylene to butyraldehyde

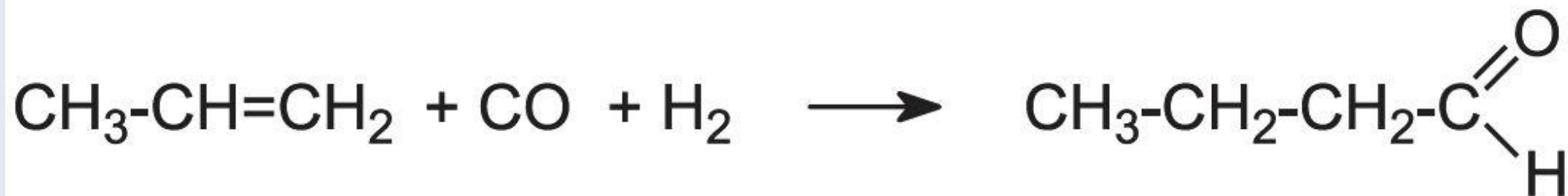

C. Nitration of toluene to o-nitrotoluene

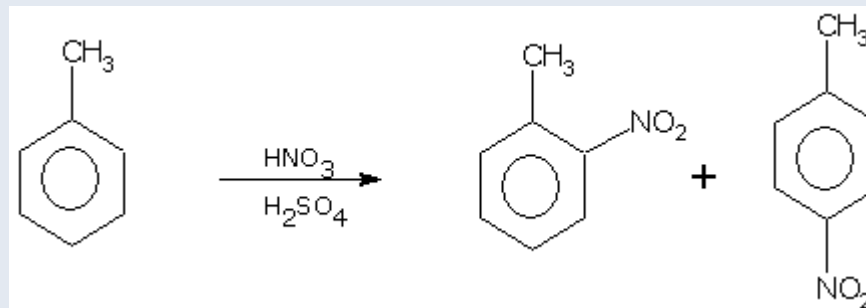

D. Oxidation of cumene to cumene hydroperoxide using oxygen

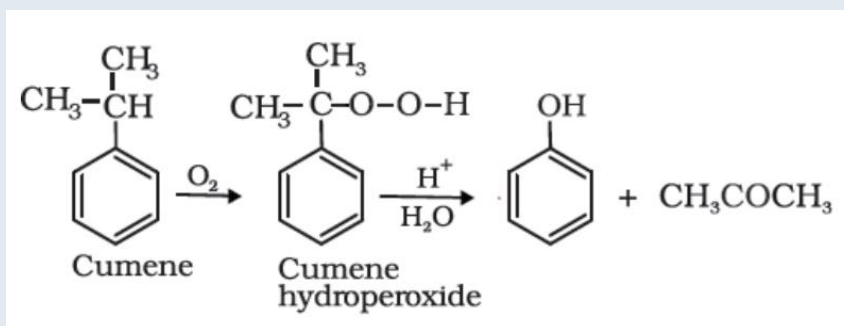

E. Isomerization of n-butane to isobutane

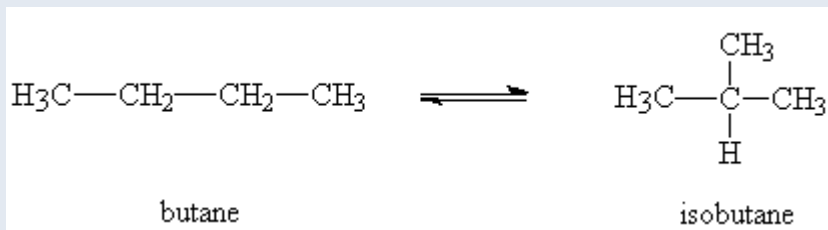

Q(105). Answer each of the following questions in one sentence.

A. What function does the membrane perform in the membrane cell for the manufacture of NaOH ?

B. What is the generic chemical name for the class of polymers which are commercially known as nylons ?

C. Name the commonly used process for the class of polymers which are commercially known as nylons ?

D. What change in the design of the synthesis gas compressors has revolutionised the ammonia manufacture during the recent years?

E. State the major advantage of the Kraft process over the processes for the manufacture of paper pulp?

Ans:-

- A. The purpose of membrane is to exclude OH^- and Cl^- ions from the anode chamber.
- B. Nylon is a generic designation for a family of synthetic polymers, based on aliphatic or semi-aromatic polyamides. Nylon 6,6 (Hexamethylene diamine & Adipic Acid) And Nylon 6 (Caprolectum).
- C. DuPont is the commonly used process for the class of polymers which are commercially known as nylons .
- D. A highly unique assembly of integral shrouded blades, a new profile design procedure for both fluid loss reduction and increased strength against high speed and high stage power. Other useful applications of new technologies to reduce steam leakage and increase last stage blade performance are introduced.

Use Code: DEVENDRAPOONIA to get 10% off on Plus Subscription

E. Sulfate (Kraft) Pulping Process:-

- Most popularly used process.
- This is an alkaline process.
- Na_2SO_4 is added to the cooking liquor. So its common name is sulfate process.
- **The presence of sodium sulfide makes bleaching of pulp easier and the paper produced has better strength.**

Q(106). In petroleum refining, the process used for conversion of hydrocarbons to aromatics is

(A) catalytic cracking

(B) catalytic reforming

(C) hydrotreating

(D) alkylation

(GATE 2000)

Use Code: DEVENDRAPOONIA to get 10% off on Plus Subscription

Ans:- (B) catalytic reforming

- The reforming process is a catalytic process which converts low octane naphthas into higher octane reformatate products.
- Process re-arranges or re-structures the hydrocarbon molecules in the naphtha feedstocks as well as breaking some of the molecules into smaller molecules.
- Among the same carbon number compounds, the order of RONC is (Research Octane Number) Paraffins < Naphthenes < Aromatics.
- Branched paraffins also have high octane. It increases with degree of branching.

Q(107). Commercially, ethylene is produced from naphtha by

(A) catalytic cracking

(B) catalytic dehydrogenation

(C) pyrolysis

(D) hydrocracking

(GATE 2000)

Use Code: DEVENDRAPOONIA to get 10% off on Plus Subscription

Ans:- (D) hydrocracking

➤ Ethylene can produced by

1. Steam cracking of naphtha
2. Hydrocracking of naphtha

Q(108). Triple superphosphate is manufactured by reacting –

- (A) Phosphate rock with phosphoric acid
- (B) Phosphate rock with sulphuric acid
- (C) Phosphate rock with nitric acid
- (D) Ammonium phosphate with phosphoric acid

(GATE 2000)

Ans :- (A) Phosphate rock with phosphoric acid

Single Superphosphate (SSP) –

[Rock phosphate + Sulfuric Acid]

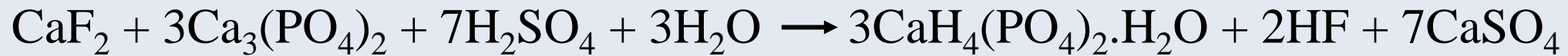

Triple Superphosphate (TSP) –

[Rock phosphate + Phosphoric Acid]



Diamonium Phosphate (DAP) –

[Rock phosphate + Sulfuric Acid + Ammonia]

Q(109). Select the process from the right-hand column which matches with the catalyst given in the left-hand column (write both answers in Box No.)

- | | | |
|-----|----------|------------------------------------|
| I. | Nickel | A) Hydrogenation of vegetable oils |
| II. | Zeolites | B) Ammonia synthesis |
| | | C) Catalytic cracking of gas oil |
| | | D) Alkylation |
| | | E) Sulphuric acid manufacture |
| | | F) Nitric acid manufacture |
| | | G) Methanol synthesis |
| | | H) Ethylene oxide manufacture |

(GATE 2000)

Use Code: DEVENDRAPOONIA to get 10% off on Plus Subscription

Ans:-

Hydrogenation of vegetable oils:-

- Unsaturated fats can be made into saturated fats.
- A **nickel** catalyst is used to speed up the reaction.

Fluidized Catalytic Cracking (FCC):-

- Important conversion process in petroleum refineries.
- High molecular weight long chain hydrocarbons are cracked into the small molecules like Gasoline.
- Raw Material – Heavy Gas oil or Vacuum gas oil.
- Final product – Low mol. wt. small chain HCs
- Catalyst used- **zeolite**

Use Code: DEVENDRAPOONIA to get 10% off on Plus Subscription

Q(110). Each of the products mentioned in the left-hand column requires one or more of the reactants mentioned in the right-hand column. Match the products with the appropriate reactant(s).

I) Phthalic anhydride

II) Cumene

A) Benzene

B) Naphthalene

C) Carbon monoxide

D) Phenol

E) Propylene

F) Air

G) Ethyl benzene

H) Hydrogen

Ans:- I) Phthalic anhydride – (B) Naphthalene

II) Cumene – (D) Phenol

Oxidation of Naphthalene to Phthalic Anhydride:-

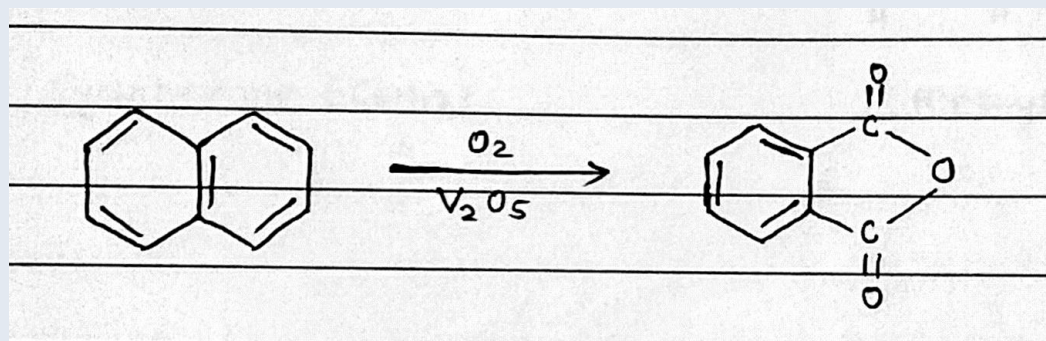

Cumene to phenol:- Peroxidation

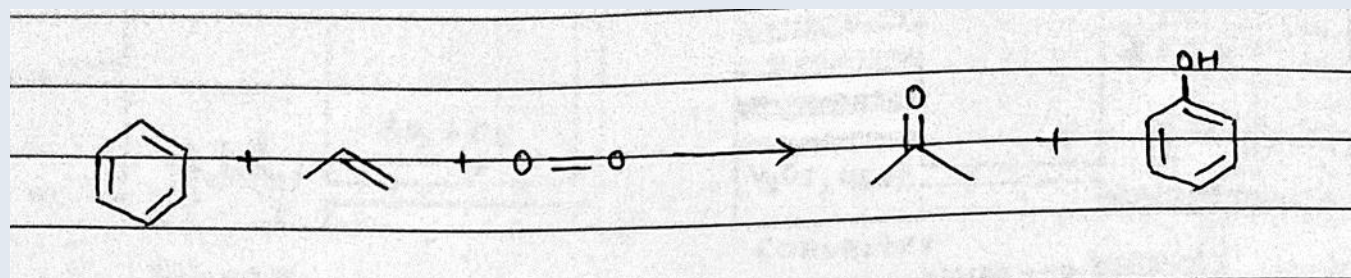

Use Code: DEVENDRAPOONIA to get 10% off on Plus Subscription

Q(111). Synthesis gas is not a mixture of

(A) CO and H₂

(B) N₂ and H₂

(C) H₂, CH₄ and CO

(D) CO₂ and H₂

(GATE 2000)

Use Code: DEVENDRAPOONIA to get 10% off on Plus Subscription

Ans:- (C) H_2 , CH_4 and CO

- Synthesis gas or briefly, syngas, is a mixture of carbon monoxide, carbon dioxide and hydrogen.
- $1N_2$ and $3H_2 \Rightarrow$ Ammonia synthesis gas

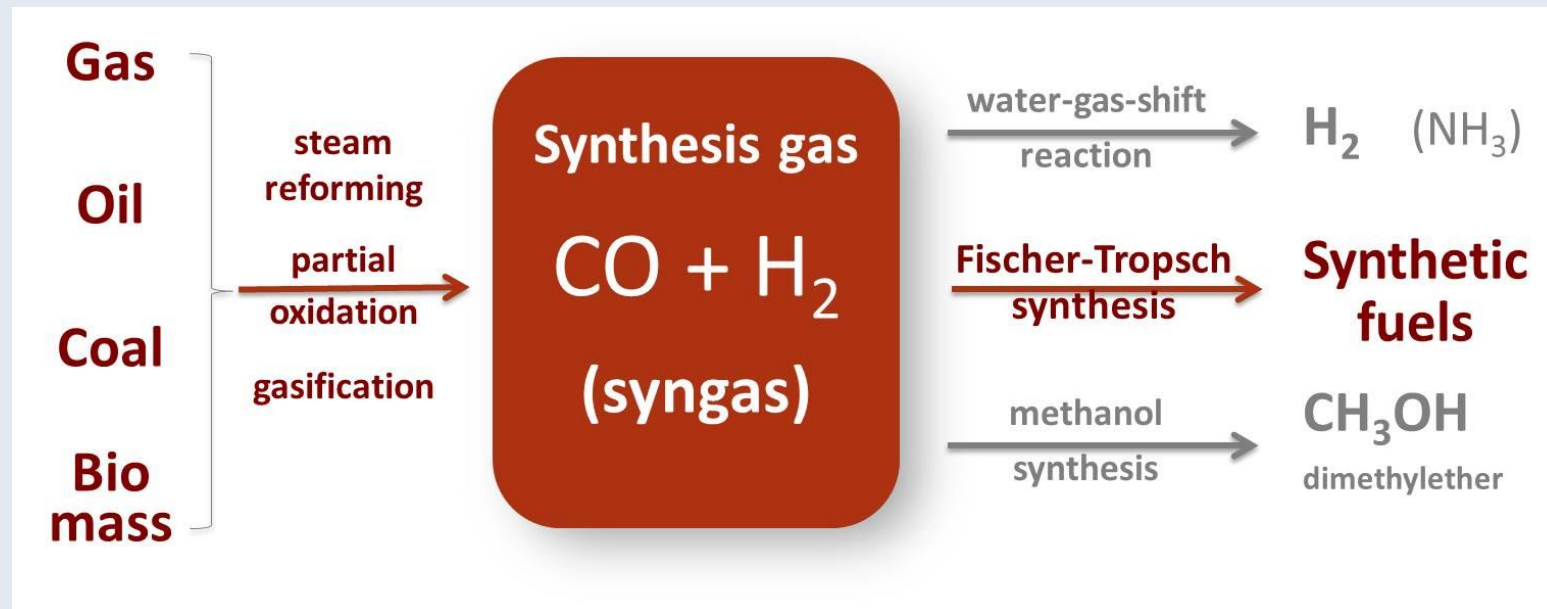

Q(112). Solvent used in extractive distillation

- (A) is of low volatility
- (B) forms a low-boiling azeotrope
- (C) forms a high-boiling azeotrope
- (D) does not alter the relative volatility of the original components

(GATE 1999)

Ans:- (A) is of low volatility

- To a binary mixture which is difficult or impossible to separate by ordinary means, a third component, termed a solvent, is added which **alters the relative volatility** of the original constituents, thus permitting the separation.
- The added solvent is, however, of **low volatility** and is itself not appreciably vaporised in the fractionator.
- It is important to note that the solvent must **not form an azeotrope** with any of the components.

Use Code: DEVENDRAPOONIA to get 10% off on Plus Subscription

Q(113). The recovery of penicillin from the acidified fermentation broth is done by

(A) distillation

(B) evaporation

(C) absorption

(D) liquid extraction

(GATE 1999)

Use Code: DEVENDRAPOONIA to get 10% off on Plus Subscription

Ans:- (D) liquid extraction

Extraction of Penicillin with Solvent:-

- For penicillin recovery, it is standard practice to use liquid-liquid countercurrent extraction processes.
- Liquid-liquid extraction is suitable for the recovery of penicillin because of its operation at low temperatures, greater selectivity and is less expensive compared to distillation, evaporation and membrane technology.

Q(114). Sucrose is a disaccharide consisting of

(A) glucose and glucose

(B) glucose and fructose

(C) glucose and galactose

(D) fructose and galactose

(GATE 1999)

Use Code: DEVENDRAPOONIA to get 10% off on Plus Subscription

Ans:- (B) glucose and fructose

➤ **Glucose and fructose** are monosaccharides and are the building blocks of **sucrose**, a disaccharide.

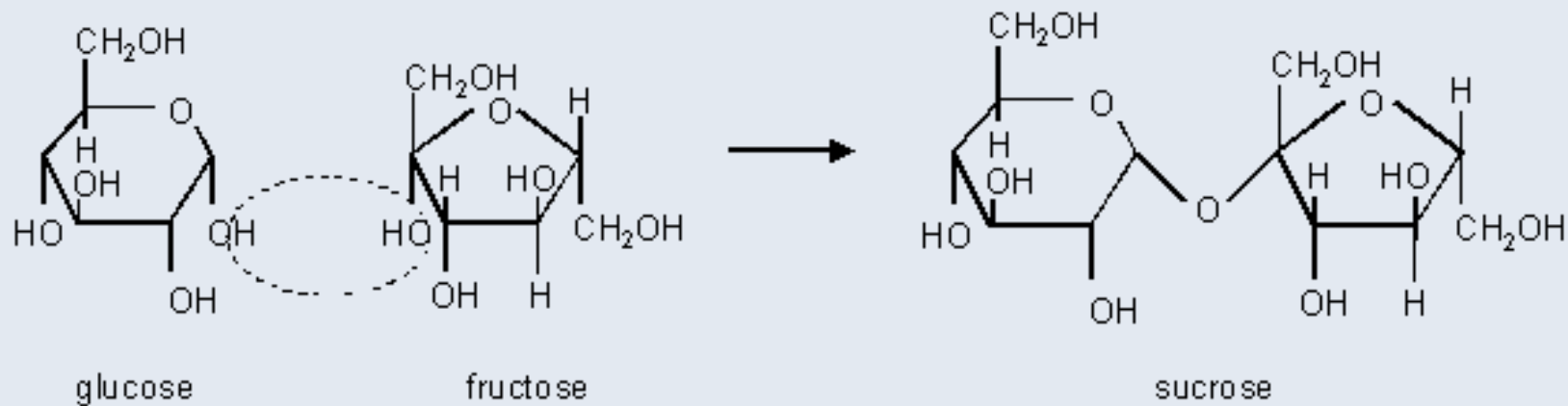

Use Code: DEVENDRAPOONIA to get 10% off on Plus Subscription

Q(115). The organic acid monomer in Nylon 66 is –

(A) Sebacic acid

(B) Terephthalic acid

(C) Adipic acid

(D) Benzoic acid

(GATE 1999)

Use Code: DEVENDRAPOONIA to get 10% off on Plus Subscription

Ans:- (C) Adipic acid

Nylon 66 :-

➤ **Monomers-**

(i) hexamethylene diamine (HMD)

(ii) adipic acid

➤ **Reaction:-**

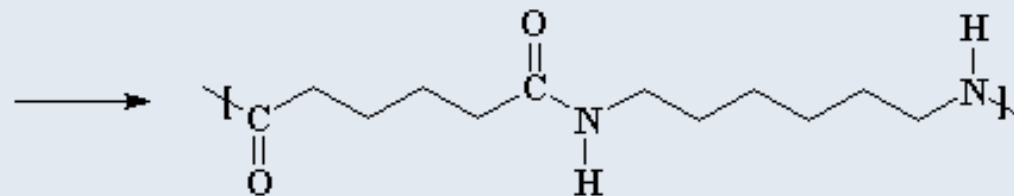
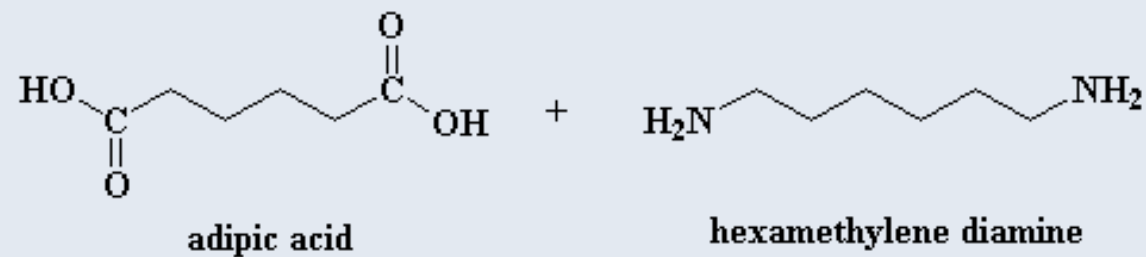

Q(116). Which one of the following is not likely to be a constituent of vegetable oils ?

(A) Citric acid

(B) Oleic acid

(C) Stearic acid

(D) Glycerol

(GATE 1999)

Use Code: DEVENDRAPOONIA to get 10% off on Plus Subscription

Ans:- (A) Citric acid

- Oils are organic molecule of carbon, hydrogen, oxygen and sometimes nitrogen and sulfur.
- It is composed of long chain fatty acids and esters (glyceride ester) as well as derivative of glycerine, long chain fatty alcohol, sulfate and sulfonates.
- Oleic acid ($C_{17}H_{33}COOH$) and Stearic acid ($C_{17}H_{35}COOH$) are long chain fatty acids.
- Oil is used in producing vanaspati ghee, soaps and detergents, cosmetics, medicines, polymers, paints and varnishes and in many other applications.

Q(117). Match each polymer mentioned in the left-hand column with the corresponding chemical nature listed in the right-hand column.

I) Perspex

A) Polysaccharide

II) Dacron

B) Polyamide

C) Polyacrylate

D) Polyester

E) Polyether

F) Polyolefin

(GATE 1999)

Ans:- I) Perspex - C) Polyacrylate

II) Dacron - D) Polyester

Perspex:-

➤ Perspex is the trade name of Poly(methyl methacrylate) (PMMA)

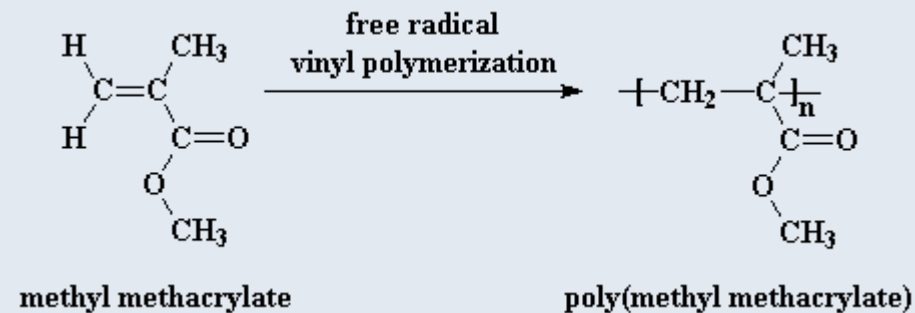

Rayon:-

➤ Rayon - Cellulose

➤ Dacron (Terylene) - Polyester (PET)

➤ Orlon - Acrylic

Q(118). Write the overall chemical reaction (stoichiometrically balanced) for the manufacture of each of the following chemicals –

- a) vinyl acetate and ethylene b) urea from ammonia
c) styrene from ethyl benzene d) caustic soda from brine
e) triple superphosphate from phosphate rock

(GATE 1999)

Ans:- (a) vinyl acetate from ethylene:-

Ethylene-vinyl acetate (EVA), also known as **poly (ethylene-vinyl acetate) (PEVA)**, is the copolymer of ethylene and vinyl acetate.

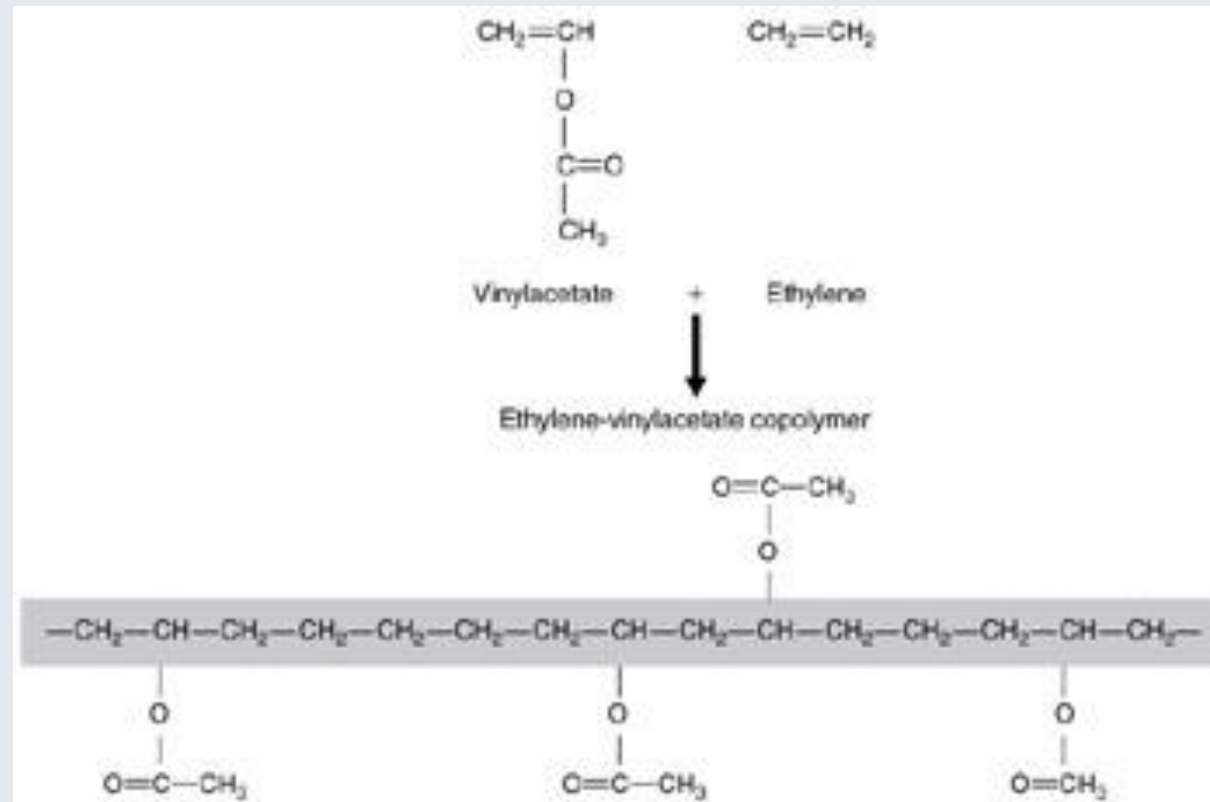

Use Code: DEVENDRAPOONIA to get 10% off on Plus Subscription

(b) urea from ammonia:-

Urea:-

Raw Materials:-

- (i) Excess liquid ammonia can be synthesized by Haber – Bosch
- (ii) Compressed Carbon dioxide from synthesis gas

Reactions:-

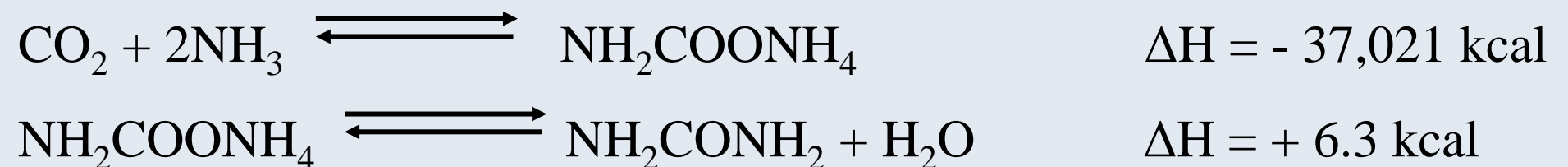

(c) styrene from ethyl benzene :-

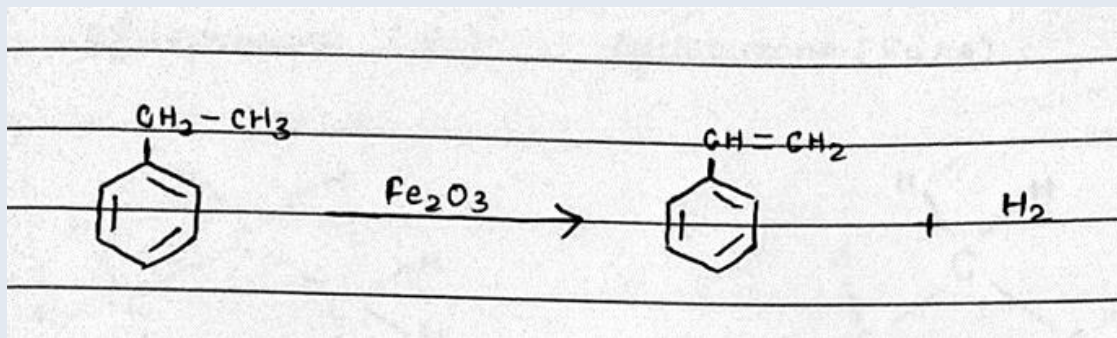

(d) caustic soda from brine :-

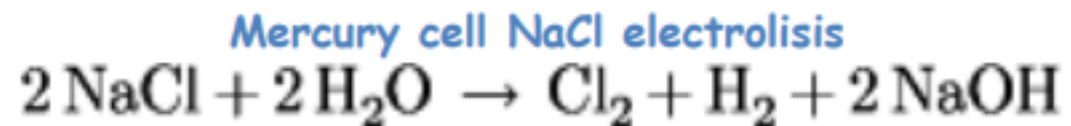

Single Superphosphate (SSP) –

[Rock phosphate + Sulfuric Acid]

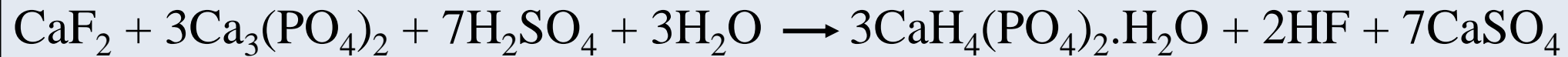

Triple Superphosphate (TSP) –

[Rock phosphate + Phosphoric Acid]



Diamonium Phosphate (DAP) –

[Rock phosphate + Sulfuric Acid + Ammonia]

Q(119). In the context of the chemical process industries, the term BOD is normally associated with

- (A) Characterization of solid wastes
- (B) The organic concentration in gaseous effluents
- (C) Characterization of liquid effluents
- (D) Characterization of boiler feed water

(GATE 1998)

Ans:- (C) Characterization of liquid effluents

Biochemical Oxygen Demand (BOD):-

The BOD can be defined as the oxygen required for biochemical oxidation of organic matter present in the water under aerobic conditions.

Use Code: DEVENDRAPOONIA to get 10% off on Plus Subscription

Q(120). Each of the chemicals mentioned in the left hand column is very closely linked with one specific industry mentioned in the right hand column. Match each chemical with the corresponding industry.

(I) Titanium dioxide

(II) Purified Terephthalic Acid

A) Detergents

B) Soaps

C) Paints and Pigments

D) Synthetic fibers

E) Nuclear Fuels

F) Synthetic Rubber

(GATE 1998)

Use Code: DEVENDRAPOONIA to get 10% off on Plus Subscription

Ans:- (I) Titanium dioxide- C) Paints and Pigments

(II) Purified Terephthalic Acid - D) Synthetic fibers

Titanium dioxide-

➤ Titanium dioxide (TiO_2) is a naturally occurring mineral used as a bright white pigment for paint, in the food industry as a coloring, in sunscreens and cosmetics, and in other industrial uses. After processing, it exists as white, powdery solid.

Purified Terephthalic Acid-

➤ Terephthalic acid is an organic compound with formula $\text{C}_6\text{H}_4(\text{CO}_2\text{H})_2$. This white solid is a commodity chemical, used principally as a precursor to the polyester PET, used to make synthetic fibers and plastic bottles.

Use Code: DEVENDRAPOONIA to get 10% off on Plus Subscription

Q(121). Each of the byproducts / coproducts mentioned in the left hand column is linked to one of the main products mentioned in the right hand column. Match the byproducts/coproducts with the corresponding main products.

(I) Glycerine

A) Rocket Propellant

(II) Ammonium Chloride

B) Soda Ash

C) Battery grade MnO_2

D) Antibiotics

E) Soap

F) Sugar

(GATE 1998)

Ans:- (I) Glycerine – E) Soap

(II) Ammonium Chloride – B) Soda Ash

Glycerine:-

- It is a byproduct from soap manufacture.

Ammonium Chloride:-

- It is a product of the Solvay process used to produce sodium carbonate.
- $\text{CO}_2 + 2 \text{NH}_3 + 2 \text{NaCl} + \text{H}_2\text{O} \rightarrow 2 \text{NH}_4\text{Cl} + \text{Na}_2\text{CO}_3$

Q(122). Each of the techniques/processes/operations mentioned in the left hand column is closely related to a specific industry mentioned in the right hand column. Match each technique/process/operation with the appropriate industry.

(I) Granulation

A) Cement

(II) Fluid Catalytic Cracking

B) Petroleum Refining

C) Ammonium Phosphates

D) Urea

E) Phosphoric Acid

F) Glass

(GATE 1998)

Use Code: DEVENDRAPOONIA to get 10% off on Plus Subscription

Ans:- (I) Granulation – (D) Urea

(II) Fluid Catalytic Cracking – (B) Petroleum Refining

Urea manufacture -

➤ Prilling tower used to convert fertilizer into the granular form.

Fluid Catalytic Cracking (FCC):-

➤ Important conversion process in petroleum refineries.

➤ High molecular weight long chain hydrocarbons are cracked into the small molecules like Gasoline.

➤ Raw Material – Heavy Gas oil or Vacuum gas oil.

➤ Final product – Low mol. wt. small chain HCs

➤ Catalyst used- zeolite

Use Code: DEVENDRAPOONIA to get 10% off on Plus Subscription

Q(123). Each item of equipment mentioned in the left hand column is identified with the manufacturing process for one of the products mentioned in the right hand column. Match the equipment with the corresponding product.

(I) Fermentor

(II) membrane Cell

(III) Waste heat boiler

(IV) Rotary kiln

(V) Prilling Tower

(A) Ammonium nitrate

(B) Ethanol from molasses

(C) Caustic soda

(D) Di Ammonium phosphate

(E) Sulphuric acid

(F) Cement

(G) Yellow phosphorus

(H) Sodium metal

(GATE 1998)

Ans:-

- | | | |
|-------------------------|---|---------------------------|
| (I) Fermentor | - | (B) Ethanol from molasses |
| (II) membrane Cell | - | (C) Caustic soda |
| (III) Waste heat boiler | - | (E) Sulphuric acid |
| (IV) Rotary kiln | - | (F) Cement |
| (V) Prilling Tower | - | (D) Di Ammonium phosphate |

Use Code: DEVENDRAPOONIA to get 10% off on Plus Subscription

Q(124). Each of the products mentioned in the left hand column requires one or more of the raw materials/starting materials mentioned in the right hand column. Match the products with the appropriate raw material(s)/starting material(s).

(I) Urea

(II) Phenol

(A) Air

(B) Toluene

(C) Carbon dioxide

(D) Nitric oxide

(E) Methanol

(F) Ammonia

(G) Propylene

(H) Cumene

Ans:- (I) Urea – (C) Carbon dioxide (F) Ammonia

(II) Phenol – (A) Air (H) Cumene

Urea:-

Raw Materials:-

(i) Excess liquid ammonia can be synthesized by Haber – Bosch

(ii) Compressed Carbon dioxide from synthesis gas

Reactions:-



Cumene to phenol:- Peroxidation

Peroxidation: Cumene + Air \rightarrow Cumene Hydroperoxide.

Hydrolysis: Cumene Hydroperoxide + $\text{H}_2\text{SO}_4 \rightarrow$ Phenol + Acetone.

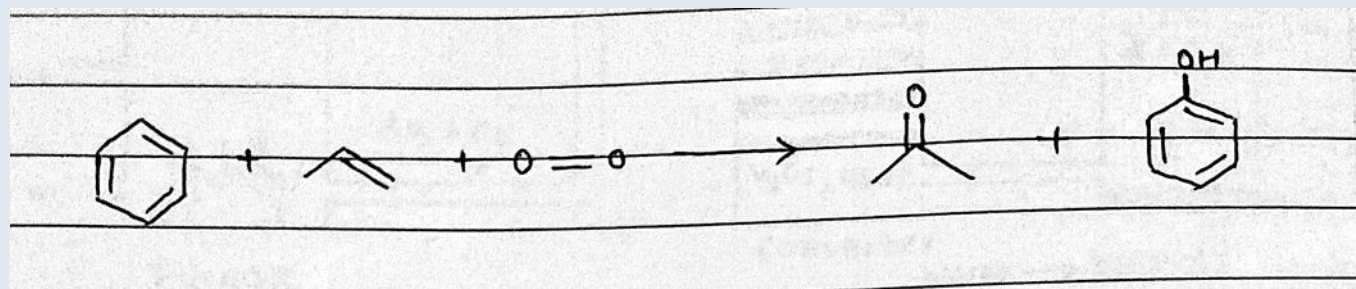

Q(125). Which of the following gaseous fuels is likely to have the highest Gross Calorific value ?

(A) Sewage Gas

(B) L P G

(C) Producer Gas

(D) Natural Gas

(GATE 1998)

Use Code: DEVENDRAPOONIA to get 10% off on Plus Subscription

Ans:- (B) L P G

The calorific value (briefly written as CV) or heat value of a solid or liquid fuel may be defined as the amount of heat given out by the complete combustion of 1 kg of fuel.

expressed in terms of kJ / kg of fuel. The calorific value of gaseous fuels is, however, expressed in terms of kJ / m³ at a specified temperature and pressure.

Following are the two types of the calorific value of fuels:

- 1. Gross or higher calorific value*
- 2. Net or lower calorific value*

Gaseous fuel	Gross Calorific Value
Sewage Gas	13.8 MJ/kg
L P G	46.1 MJ/kg
Producer Gas	5 MJ/kg
Natural Gas	37.3 MJ/kg

Use Code: DEVENDRAPOONIA to get 10% off on Plus Subscription

Q(126). Match the items in the left column with the appropriate items in the right column.

i) Naphtha

ii) Sodium hydroxide

A) Solvay process

B) Steam reforming

C) Mercury cell

D) DCDA process

(GATE 1997)

Ans:- i) Naphtha – (B) Steam reforming

ii) Sodium hydroxide – (C) Mercury cell

➤ Typical feed stocks are Naphtha for steam reforming to produce various petrochemicals.

➤ **Cells which are used for production of caustic soda are:-**

1. Diaphragm cell
2. Mercury cathode cell
3. Membrane cell

Q(127). Match the items in the left column with the appropriate items in the right column.

- | | |
|-------------------|---|
| i) LPG | A) CO, CO ₂ , H ₂ |
| ii) Synthesis gas | B) C ₂ H ₄ , C ₃ H ₈ |
| | C) C ₃ H ₈ , C ₄ H ₁₀ |
| | D) CO, H ₂ |

(GATE 1997)

Ans:- (i) LPG – (C) C_3H_8 , C_4H_{10}

ii) Synthesis gas – (A) CO , CO_2 , H_2

- **Liquefied petroleum gas or liquid petroleum gas (LPG or LP gas)**, also referred to as simply propane or butane.
- **Synthesis gas or briefly, syngas**, is a mixture of carbon monoxide, carbon dioxide and hydrogen.

Q(128). Match the items in the left column with the appropriate items in the right column.

- | | |
|---------------------------------|-------------------------|
| i) Global warming | A) unleaded gasoline |
| ii) Methyl tertiary butyl ether | B) nitrous oxides |
| | C) chlorofluoro-carbons |
| | D) leaded gasoline |

(GATE 1997)

Ans:- i) Global warming – (C) chlorofluoro-carbons

ii) Methyl tertiary butyl ether – (D) leaded gasoline

- **Methyl tert-butyl ether (MTBE)** is a gasoline additive used as an oxygenate and to raise the octane number. Its use has declined in the United States in response to environmental and health concerns. It has polluted groundwater due to MTBE-containing gasoline being spilled or leaked at gas stations.
- The main difference between leaded petrol and unleaded petrol is the additive tetraethyl lead.

Q(129). Na_2CO_3

(A) Haber process

(B) Solvay process

(C) Fischer - Tropsch process

(D) Castner - Kellner process

(GATE 1997)

Use Code: DEVENDRAPOONIA to get 10% off on Plus Subscription

Ans:- (B) Solvay process

Solvay Process:-

- The Solvay process or ammonia-soda process is the major industrial process for the production of sodium carbonate & sodium hydrogen carbonate.
- The ingredients for this process are readily available and inexpensive: salt brine (from inland sources or from the sea) and limestone (from mines).
- The Solvay process results in soda ash (Na_2CO_3) from brine (NaCl) and from limestone (CaCO_3).
- $2 \text{NaCl} + \text{CaCO}_3 \rightarrow \text{Na}_2\text{CO}_3 + \text{CaCl}_2$
- $\text{NaCl} + \text{CO}_2 + \text{NH}_3 + \text{H}_2\text{O} \rightarrow \text{NaHCO}_3 + \text{NH}_4\text{Cl}$

Use Code: DEVENDRAPOONIA to get 10% off on Plus Subscription

Q(130) Prilling tower

(A) Cement

(B) Potassium chloride

(C) Urea

(D) Triple superphosphate

(GATE 1997)

Use Code: DEVENDRAPOONIA to get 10% off on Plus Subscription

Ans:- (C) Urea

Urea manufacture -

➤ Prilling tower used to covert fertilizer into the granular form.

Use Code: DEVENDRAPOONIA to get 10% off on Plus Subscription

Q(131) Extractive distillation

- (A) Nitric acid
- (B) Caustic soda
- (C) Sulfuric acid
- (D) Urea

(GATE 1997)

Ans:- (A) Nitric acid

Production of concentrated nitric acid

(1) Direct processes

(2) Indirect processes

- Indirect processes are based on **extractive distillation** and rectification of weak nitric acid. Sulphuric acid or magnesium nitrate is used as the dehydrating agent. With sulphuric acid processes, weak nitric acid is preheated and distilled with H_2SO_4 . With magnesium nitrate processes, a solution of $\text{Mg}(\text{NO}_3)_2$ is used to extract water from the nitric acid.

Q(132) Linear alkyl benzene sulphonate

(A) Detergents

(B) Perfumes

(C) Pharmaceuticals

(D) Refrigerants

(GATE 1997)

Use Code: DEVENDRAPOONIA to get 10% off on Plus Subscription

Ans:- (A) Detergents

Linear alkylbenzene sulphonate (LAS) is an anionic surfactant used in detergent.

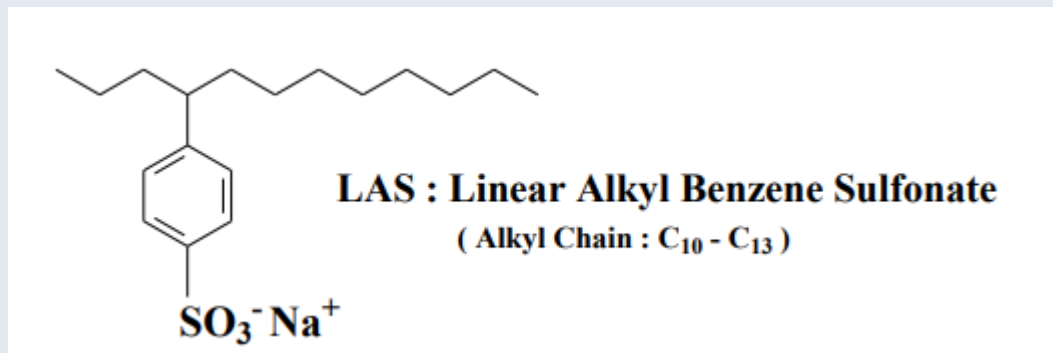

Use Code: DEVENDRAPOONIA to get 10% off on Plus Subscription

Q(133). V_2O_5

(A) Ammonia

(B) Sulfuric acid

(C) Polypropylene

(D) Nylon

(GATE 1997)

Use Code: DEVENDRAPOONIA to get 10% off on Plus Subscription

Ans:- (B) Sulfuric acid

Contact Process of Sulfuric acid production -

- Currently high concentrated sulphuric acid is produced.
- Vanadium pentoxide (V_2O_5) used as catalyst.
- More economical than lead chamber process.
- Can also produce SO_3 and oleum.

Q(134). Styrene-Butadiene rubber is commercially manufactured by :

- (A) Bulk polymerization
- (B) Suspension polymerization
- (C) Solution polymerization
- (D) Emulsion polymerization

(GATE 1996)

Ans:- (D) Emulsion polymerization

Emulsion polymerization:-

- Produces polymers with very high molecular weights.
- It is used for the production of polymers requiring high molecular weights such as Styrene Butadiene elastomer (SBR) and Teflon.

Use Code: DEVENDRAPOONIA to get 10% off on Plus Subscription

Q(135). Give five advantages of cement production by Dry Method compared with Wet Method.

(GATE 1996)

Use Code: DEVENDRAPOONIA to get 10% off on Plus Subscription

Ans:-

Comparison between wet and dry process

Wet process	Dry process
1- Moisture content of the slurry is 35-50%	1- Moisture content of the pellets is 12%
2- Size of the kiln needed to manufacture the cement is bigger	2- Size of the kiln needed to manufacture the cement is smaller
3- The amount of heat required is higher, so the required fuel amount is higher	3- The amount of heat required is lower, so the required fuel amount is lower
4- Less economically	4- More economically
5- The raw materials can be mix easily, so a better homogeneous material can be obtained	5- Difficult to control the mixing of raw materials process, so it is difficult to obtain homogeneous material
6- The machinery and equipments do not need much maintenance	6- The machinery and equipments need more maintenance

Q(136). What are the catalysts employed in the following commercial reactor operations ?

- (i) oxidation of SO_2
- (ii) oxidation of NH_3
- (iii) oxidation of C_2H_4
- (iv) hydrogenation of vegetable oil
- (v) dehydrogenation of propan-2-ol

(GATE 1996)

Ans:-

Processes

Catalyst

- | | | |
|-------------------------------------|---|---|
| oxidation of SO_2 | - | vanadium pentoxide (V_2O_5) |
| oxidation of NH_3 | - | Platinum-Rhodium make up catalyst |
| oxidation of C_2H_4 | - | Silver catalyst |
| hydrogenation of vegetable oil | - | Raney nickel |
| dehydrogenation of propan-2-ol | - | Copper |

Use Code: DEVENDRAPOONIA to get 10% off on Plus Subscription

Q(137). During coking of coal, the ash content (percentage)

(A) increases

(B) decreases

(C) remains constant

(D) none of these

(GATE 1995)

Ans:- (A) increases

Coking of coal:-

➤ Raw material is Bituminous coal.

Chemical reaction:-



Coal

Benzene

Coke

Lighter hydrocarbon

Q(138). (I) catalytic reforming

(II) smoke point

(A) high speed diesel

(B) kerosene

(C) gasoline

(D) aromatics

(GATE 1995)

Use Code: DEVENDRAPOONIA to get 10% off on Plus Subscription

Ans:- (I) catalytic reforming – (D) aromatics

(II) smoke point – (B) kerosene

- catalytic reforming is used to convert Paraffins and naphthenes to aromatics.
- The major properties of kerosene that determine its burning quality are the smoke point and the flash point.
- The smoke point is determined as the height of the flame (in millimetres) produced by this oil in the wick of a stove or a lamp without forming any smoke. The greater the smoke point, the better the burning quality. Domestic kerosene should have a smoke point of 20 mm (minimum).

Use Code: DEVENDRAPOONIA to get 10% off on Plus Subscription

Q(139). Solvay process is used for the manufacture of,

- (A) Caustic soda
- (B) Soda ash
- (C) Caustic potash
- (D) Soda lime

(GATE 1994)

Ans:- (B) Soda ash

Solvay Process:-

- The Solvay process or ammonia-soda process is the major industrial process for the production of sodium carbonate & sodium hydrogen carbonate.
- The ingredients for this process are readily available and inexpensive: salt brine (from inland sources or from the sea) and limestone (from mines).
- The Solvay process results in soda ash (Na_2CO_3) from brine (NaCl) and from limestone (CaCO_3).
- $2 \text{NaCl} + \text{CaCO}_3 \rightarrow \text{Na}_2\text{CO}_3 + \text{CaCl}_2$
- $\text{NaCl} + \text{CO}_2 + \text{NH}_3 + \text{H}_2\text{O} \rightarrow \text{NaHCO}_3 + \text{NH}_4\text{Cl}$

Use Code: DEVENDRAPOONIA to get 10% off on Plus Subscription

Q(140). Phthalic anhydride is produced by the oxidation of,

- (A) Naphthalene
- (B) Benzene
- (C) Toluene
- (D) Aniline

(GATE 1994)

Ans:- (A) Naphthalene

Oxidation of Naphthalene to Phthalic Anhydride:-

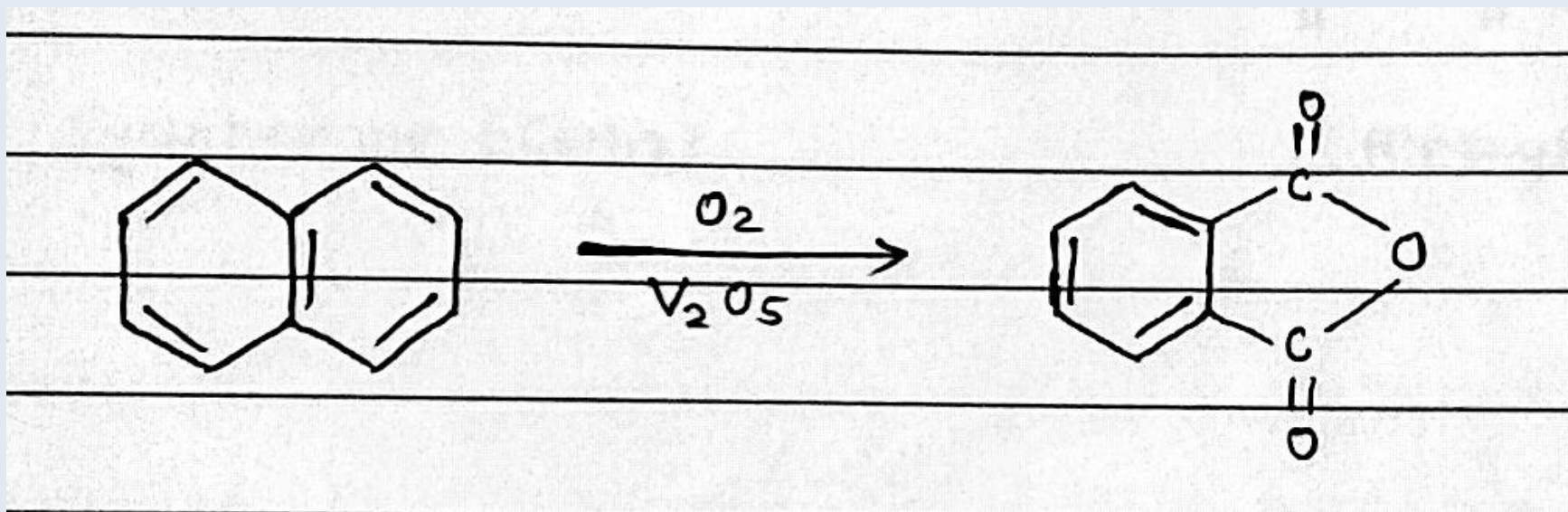

- Catalyst: Vanadium pentoxide.
- Reaction is highly exothermic.

Use Code: DEVENDRAPOONIA to get 10% off on Plus Subscription

Q(141). Which of the following fuels has the highest calorific value per unit mass?

(A) Coal

(B) Kerosene

(C) Natural gas

(D) Furnace oil

(GATE 1994)

Use Code: DEVENDRAPOONIA to get 10% off on Plus Subscription

Ans:- (C) Natural gas

The amount of energy generated when 1 unit mass of fuel is burnt completely is known as the calorific value of the fuel.

Type of fuel	Fuel	Calorific value	
		kJ/g	kwh/kg
Solid	Charcoal	33	10.7
	Coal	25.33	8.1
	Wood	17	5.5
	Dung cake	6 to 8	2 to 2.6
Liquid	Kerosene	48	15.5
	Petrol	50	
	Diesel	45	15.5
	Ethanol	30	9.7
Gaseous	Bio gas	35 to 40	11.3 to 20.9
	Butane (LPG)	50	
	Methane (main constituent of natural gas)	55	17.8
	Hydrogen	150	48.5

Use Code: DEVENDRAPOONIA to get 10% off on Plus Subscription

Q(142). The most widely used coagulant for removing suspended impurities from water is,

- (A) Bleaching powder
- (B) Chlorine
- (C) Calcium sulphate
- (D) Alum

(GATE 1994)

Use Code: DEVENDRAPOONIA to get 10% off on Plus Subscription

Ans:- (D) Alum



- Solids are removed by sedimentation (settling) followed by filtration. Small particles are not removed efficiently by sedimentation because they settle too slowly; they may also pass through filters. They would be easier to remove if they clumped together (coagulated) to form larger particles, but they don't because they have a negative charge and repel each other (like two north poles of a magnet).
- In coagulation, we add a chemical such as **alum** which produces positive charges to neutralize the negative charges on the particles. Then the particles can stick together, forming larger particles which are more easily removed.
- The coagulation process involves the addition of the chemical (e.g. alum) and then a rapid mixing to dissolve the chemical and distribute it evenly throughout the water.

Q(143). Double contact double absorption process is used for the manufacture of _____.

(GATE 1994)

Use Code: DEVENDRAPOONIA to get 10% off on Plus Subscription

Ans :- sulfuric acid

Explanation:-

Contact Process -

- Currently high concentrated sulphuric acid is produced.
- Vanadiumpentaoxide (V_2O_5) or Pt used as catalyst.
- More economical than lead chamber process.
- Can also produce SO_3 and oleum.

DCDA Process –

- Next steps to the Contact Process.
- SO_2 & SO_3 passed through absorption towers twice for further absorption & conversion of SO_2 to SO_3 & production of higher grade sulphuric acid.

Use Code: DEVENDRAPOONIA to get 10% off on Plus Subscription

Q(144). (I). Catalytic cracking

(II). Catalytic reforming

(A). Kerosene

(B). Gasoline

(C). Aromatics

(D). Diesel

(GATE 1994)

Ans:- (I) Catalytic cracking - (B) Gasoline.

(II) Catalytic reforming - (C) Aromatics.

- High molecular weight long chain hydrocarbons are cracked into the small molecules like Gasoline.
- Catalytic reforming is used to convert Paraffins and naphthenes to aromatics.

Q(145). Match the appropriate materials for handling the following chemicals.

(I). Concentrated Sulphuric acid

(A). Brass

(II). Caustic soda

(B). Aluminium

(C). Nickel

(D). Lead

(GATE 1994)

Ans:- (I) Concentrated Sulphuric acid (D) Lead
(II) Caustic soda (B) Aluminium

- Concentrated sulfuric acid produced by Lead chamber process.
- **Caustic soda** is used in the Bayer process of aluminium production.

Q(146). Match the appropriate catalyst with the process.

(I). Hydrogenation of vegetable oils.

(A). Iron.

(II). Ammonia synthesis.

(B). Platinum.

(C). Nickel.

(D). Zeolites.

(GATE 1994)

Ans:-

(I) Hydrogenation of vegetable oils

(C) Nickel

(II) Ammonia synthesis

(A) Iron

Hydrogenation of vegetable oils:-

- Unsaturated fats can be made into saturated fats.
- The double bonds are converted to single bonds in the reaction.
- A **raney nickel** catalyst is used to speed up the reaction.

Haber Process:-

- The Haber Process combines nitrogen from the air with hydrogen derived mainly from natural gas (methane) into ammonia.
- The reaction is reversible and the production of ammonia is exothermic.
- The catalyst is actually slightly more complicated than **pure iron**. It has potassium hydroxide added to it as a promoter - a substance that increases its efficiency.

Use Code: DEVENDRAPOONIA to get 10% off on Plus Subscription

Q(147). Match the reactions with names.

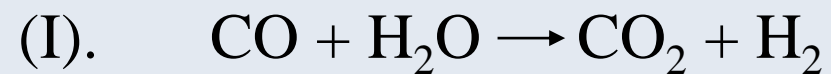

(A). Boundard reaction

(B). Water gas shift reaction

(C). Water gas reaction

(D). Steam reforming

(GATE 1994)

Ans:-

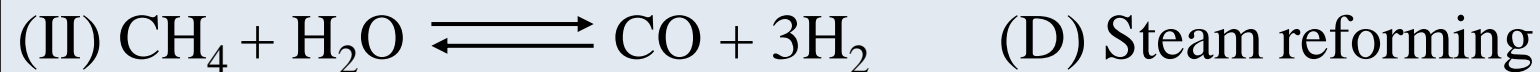
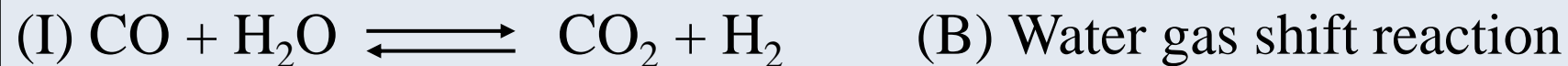

➤ Both reaction appears in the ammonia synthesis from Natural gas.

Q(148). A bio-degradable detergent is one which,

- (A) is manufactured using biotechnology
- (B) contains straight chain alkyl benzene
- (C) contains branch chain alkyl benzene
- (D) is easily decomposed by microorganisms

(GATE 1993)

Use Code: DEVENDRAPOONIA to get 10% off on Plus Subscription

Ans:- (D) is easily decomposed by microorganisms

- Detergents that can be degraded by bacteria are called biodegradable detergents. Such detergents have straight hydrocarbon chains.
- For example: sodium lauryl sulphate
- Detergents that cannot be degraded by bacteria are called non-biodegradable detergents. Such detergents have highly-branched hydrocarbon chains.
- For example: sodium -4- (1, 3, 5, 7- tetra methyl octyl) benzene sulphonate

Q(149). Hydrogenation of edible oils is done to,

- (A) Decrease the number of unsaturated bond
- (B) Lower the melting point of oil
- (C) Increase the thermal conductivity of oil
- (D) Enable the oil to be packed in tin containers

(GATE 1993)

Ans:- (A) Decrease the number of unsaturated bond

Hydrogenation Reaction:

- Unsaturated fatty acids may be converted to saturated fatty acids by the relatively simple hydrogenation reaction. Recall that the addition of hydrogen to an alkene (unsaturated) results in an alkane (saturated).
- A simple hydrogenation reaction is:
- $\text{H}_2\text{C}=\text{CH}_2 + \text{H}_2 \text{ ---> } \text{CH}_3\text{CH}_3$

Q(150).

(a). In the manufacture of Sulphuric acid why is absorption of SO_3 done in concentrated Sulphuric acid and not in water.

(b). A dilute solution (20%) of Nitric acid has to be concentrated to 80%. How is this done in industry and why?

(c). A dilute solution of glycerin contains a soluble calcium salt as impurity. Why is the removal of calcium essential before concentration of this solution? How can this removal be accomplished?

(GATE 1993)

Ans:- (a) The gases leaving the converter (where sulfur dioxide is oxidized to sulfur trioxide) are cooled in an economizer before absorption of SO_3 in concentrated sulfuric acid in a packed absorption tower. Absorption of SO_3 in water is an exothermic process and leads to evolution of large amount of heat. This results in vaporization of water and formation of acid mist and loss of acid in the effluent gas. That is why absorption of SO_3 is not done in pure water. The sulfuric acid temperature and concentration (in which SO_3 is absorbed) is usually maintained at 60-70C and 98.4-99% for good absorption.

Use Code: DEVENDRAPOONIA to get 10% off on Plus Subscription

Ans:- (b) The nitric acid concentration coming out of the absorber is in the 50-70% range and it is concentrated by either sulfuric acid dehydration process or by use of magnesium nitrate [Mg (NO₃)₂]. In the magnesium nitrate process a solution of Mg (NO₃)₂ is fed to a tray tower along with nitric acid. The salt solution acts as an extractive distillation agent and removes water at 100C. The dilute Mg (NO₃)₂ solution is reconcentrated by evaporation. As compared to the sulfuric dehydration process the Mg (NO₃)₂ process has half the operating cost, 30-40% less capital investment and results in higher yield.

Use Code: DEVENDRAPOONIA to get 10% off on Plus Subscription

Ans:- (c) The presence of calcium salt results in scale formation and fouling (and therefore decreased overall heat transfer coefficient and increased maintenance cost) on the heat transfer surface of the evpaorator. Calcium salt is precipitated out before it sent to an evaporator.

Use Code: DEVENDRAPOONIA to get 10% off on Plus Subscription

Q(151). The steps involved in the manufacture of phenol by chlorobenzene caustic process, are chlorination of benzene, _____ and _____. The process is competitive when low cost chlorine is available. This means that the process must be coupled to a _____ plant.

(GATE 1992)

Ans:- The steps involved in the manufacture of phenol by chlorobenzene-caustic process, are chlorination of benzene, **addition of caustic soda** and **hydrolysis**. The process is competitive when low cost chlorine is available. This means that the process must be coupled to a **Chlor-Alkali** plant.

Use Code: DEVENDRAPOONIA to get 10% off on Plus Subscription

Q(152). For manufacture of styrene the major raw material are _____
and _____. One important polymer of styrene is _____, which is
widely used in the manufacture of automobile tyres. (GATE 1992)

Use Code: DEVENDRAPOONIA to get 10% off on Plus Subscription

Ans:- For manufacture of styrene the major raw material are benzene and ethylene.
One important polymer of styrene is styrene butadiene rubber(SBR), which is widely used in the manufacture of automobile tires.

Use Code: DEVENDRAPOONIA to get 10% off on Plus Subscription

Q(153). Select the appropriate name from the right hand column against the processes mentioned:

(I) H₂ from light petroleum stock.

(II) High octane gasoline from naphtha.

(III) Gasoline from gas oil.

(IV) Petroleum coke from residue.

(A) Pyrolysis.

(B) Catalytic cracking.

(C) Plat forming

(D) Stream reforming of naphtha

(GATE 1992)

Use Code: DEVENDRAPOONIA to get 10% off on Plus Subscription

Ans:-

(I) H₂ from light petroleum stock

(II) High octane gasoline from naphtha

(III) Gasoline from gas oil

(IV) Petroleum coke from residue

(D) Steam reforming of naphtha

(C) Platforming

(B) Catalytic cracking

(A) Pyrolysis

Use Code: DEVENDRAPOONIA to get 10% off on Plus Subscription

Q(154). An electrostatic precipitator is normally used for separating particles from gases when,

- (A) Particle size is greater than 1 mm.
- (B) Particle size is less than 1 micron.
- (C) Gases contain high concentration of carbon monoxide.
- (D) Gases contain very high concentration of solid

(GATE 1992)

Ans:- (B) Particle size is less than 1 micron.

An **electrostatic precipitator (ESP)** is a filtration device that removes fine particles, like dust and smoke, from a flowing gas using the force of an induced electrostatic charge minimally impeding the flow of gases through the unit.

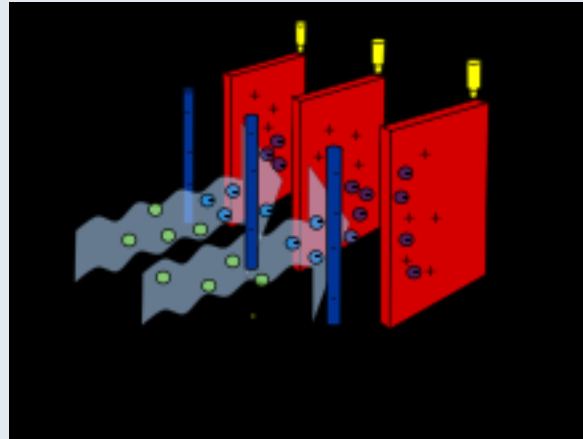

Use Code: DEVENDRAPOONIA to get 10% off on Plus Subscription

Q(155). Match the following:

(A) Phenol formaldehyde

(I) Suspension polymerization

(B) Nylon

(II) Emulsion polymerization

(C) High purity polyvinyl chloride

(III) Solution polymerization

(D) Styrene butadiene rubber

(IV) Bulk polymerization

(GATE 1991)

Ans:-

(A) Phenol formaldehyde

(B) Nylon

(C) High purity polyvinyl chloride.

(D) Styrene butadiene rubber

(III) Solution polymerization

(IV) Bulk polymerization

(I) Suspension polymerization

(II) Emulsion polymerization

Use Code: DEVENDRAPOONIA to get 10% off on Plus Subscription

Q(156). Match the following:

- | | | | |
|-----|--------------------------|-------|------------------------|
| (A) | Methanol to gasoline | (I) | Raney nickel |
| (B) | Edible oil hydrogenation | (II) | Zeolite |
| (C) | Methanation | (III) | Cat ion exchange resin |
| (D) | Butyl acetate | (IV) | Nickel |

(GATE 1991)

Ans:-

- | | | | |
|-----|--------------------------|-------|------------------------|
| (A) | Methanol to gasoline | (II) | Zeolite |
| (B) | Edible oil hydrogenation | (I) | Raney nickel |
| (C) | Methanation | (IV) | Nickel |
| (D) | Butyl acetate | (III) | Cat ion exchange resin |

Use Code: DEVENDRAPOONIA to get 10% off on Plus Subscription

Q(157). Fill in the blanks:

(a) Pure terephthalic acid is manufactured by the oxidation ----- and is used as a raw material for the manufacture of ----- (GATE 1991)

Ans:- Pure terephthalic acid is manufactured by the oxidation of p-xylene and is used as a raw material for the manufacture of polyester.

Use Code: DEVENDRAPOONIA to get 10% off on Plus Subscription

Q(158). Fill in the blanks:

In the manufacture of Portland cement the major raw materials are

-----, -----, -----, -----

(GATE 1991)

Ans:- In the manufacture of Portland cement the major raw materials are limestone,
clay, gypsum and coal.

Use Code: DEVENDRAPOONIA to get 10% off on Plus Subscription

Q(159). Match the following:

(A) Edible oil

(B) Crude oil

(C) 98% Sulphuric acid

(D) Liquid containing suspension of
abrasive solid

(I) Diaphragm pump

(II) Centrifugal pump

(III) Gear pump

(IV) Airlift pump

(GATE 1991)

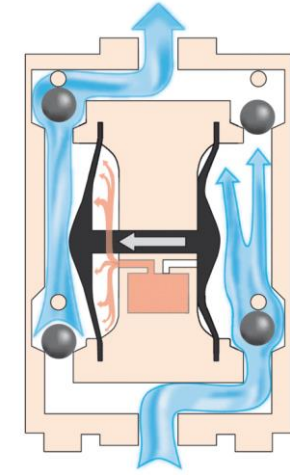
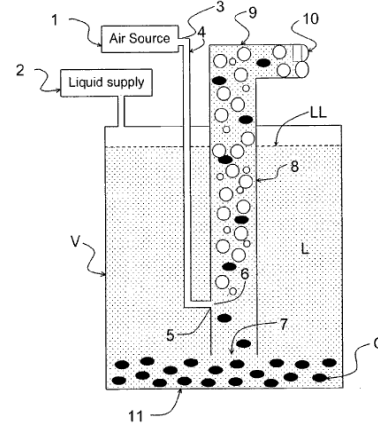
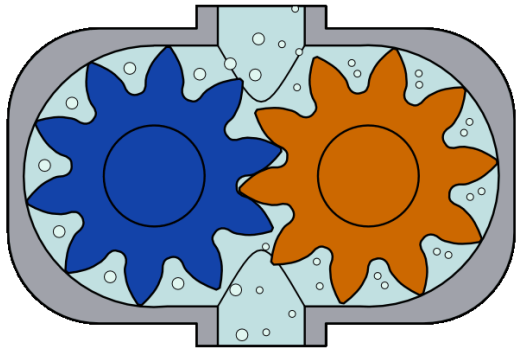

Ans:- (A) Edible oil
 (B) Crude oil from oil
 (C) 98% Sulphuric acid
 (D) Liquid containing suspension of abrasive solid

(III) Gear pump
 (IV) Airlift pump
 (II) Centrifugal pump
 (I) Diaphragm pump

Q(160). Write down the main overall reaction equation for the manufacture of following chemicals.

- (i). Soda Ash.
- (ii). Super phosphate from phosphate rock.
- (iii). Urea.
- (iv). High-octane petrol from naphtha.
- (v). Vinyl acetate from ethylene.
- (vi). Acrylonitrile from propylene.

(GATE 1991)

Ans:-

Soda Ash:

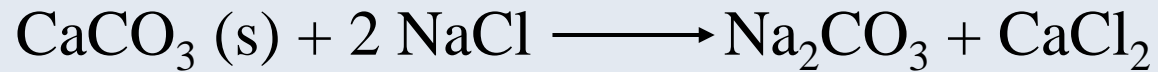

Superphosphate:



Urea:

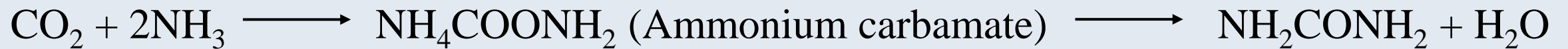

Viny acetate from ethylene:



Acrylonitrile from propylene:

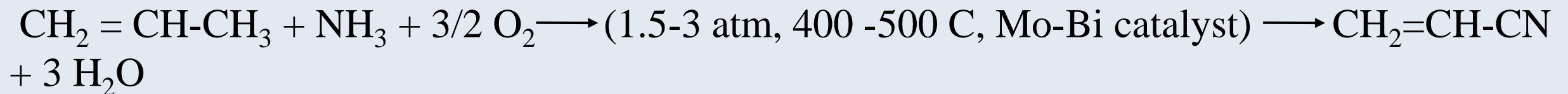

Use Code: DEVENDRAPOONIA to get 10% off on Plus Subscription

Q(161). Catalyst for platforming of petroleum feedstock is,

(A) Pt + Re

(B) Pt + Rh

(C) Pt

(D) Pt + CO

(GATE 1990)

Use Code: DEVENDRAPOONIA to get 10% off on Plus Subscription

Ans:-(A) Pt + Re

- **Catalytic Reforming** previously known as the **Platforming process**.
- **Catalytic reforming**:-Chemical process to convert petroleum refinery naphthas, typically having **low octane** ratings, into **high-octane** liquid products called reformates which are components of high-octane gasoline (also known as petrol). Process re-arranges or re-structures the hydrocarbon molecules in the naphtha feedstocks. Breakes some of the molecules into smaller molecules.
- The noble metals (**platinum and rhenium**) are considered to be catalytic sites for the dehydrogenation reactions and the chlorinated alumina provides the acid sites needed for isomerization, cyclization and hydrocracking reactions.

Use Code: DEVENDRAPOONIA to get 10% off on Plus Subscription

Q(162). Give the main reasons for the following:

(i). While $\text{SO}_2 + \frac{1}{2} \text{O}_2 \rightarrow \text{SO}_3$ is a low pressure process; $\text{N}_2 + 3\text{H}_2 \rightarrow 2\text{NH}_3$ is a high-pressure process.

(GATE 1990)

Ans:-

- SO_2 is a low pressure process, as pressure increases compression cost increases and creates corrosion problem.
- NH_3 formation is a higher pressure because increasing pressure results in higher conversion offsetting the compression cost and no such corrosion problem.

Use Code: DEVENDRAPOONIA to get 10% off on Plus Subscription

Q(163). (i). The dihydrate process is preferred to the hemihydrates process for the manufacture of commercial grade ortho phosphoric acid from its ores and sulphuric acid.

(ii). Under Indian conditions caustic soda of 50% concentration can be best prepared by the Mercury Cell Technology.

(GATE 1990)

Ans:- Phosphoric acid (H_3PO_4) also known as orthophosphoric acid.

Wet process of orthophosphoric acid (sulfuric acid and phosphate rock):-

- Depending upon the hydrate forms of calcium sulfate produced during the wet process, it is classified as anhydrate, hemi hydrate and dihydrate.
- The hydrate form is controlled mainly by temperature and acid concentration.
- Anhydrite ($n=0$) process is not commercially viable due to high temperatures requirement and the higher rate of corrosion.
- The dihydrate process is the most popular due to simplicity and ability to use a wide variety of phosphate rocks in the process.
- Hemihydrate processes produce phosphoric acid of a relatively high concentration without the need of the concentration step.

Use Code: DEVENDRAPOONIA to get 10% off on Plus Subscription

Ans:-

Advantages of dihydrate systems are:-

- There is no phosphate rock quality limitation
- Operating temperatures are low
- Start-up and shut-down are easy
- Wet rock can be used (saving drying costs)

Use Code: DEVENDRAPOONIA to get 10% off on Plus Subscription

Ans.(ii). Membrane cell technology is energy efficient, less pollution problem, that's why NaOH produced upto 50% produced.

Use Code: DEVENDRAPOONIA to get 10% off on Plus Subscription

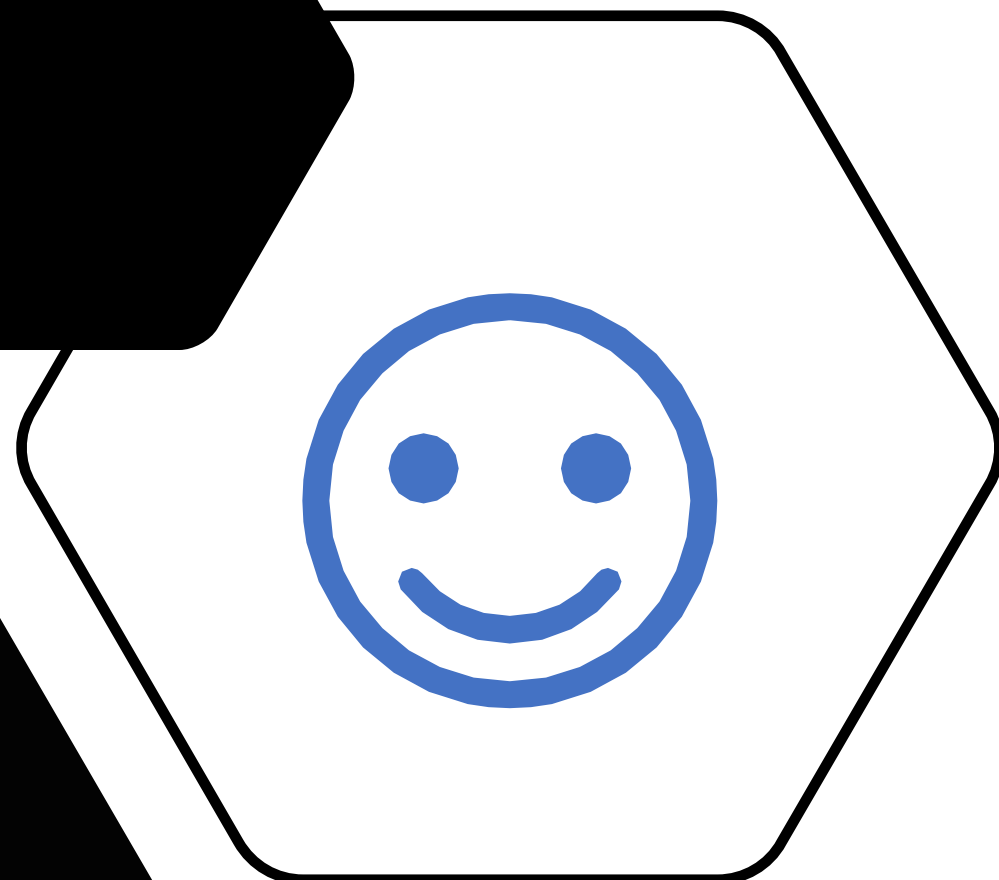
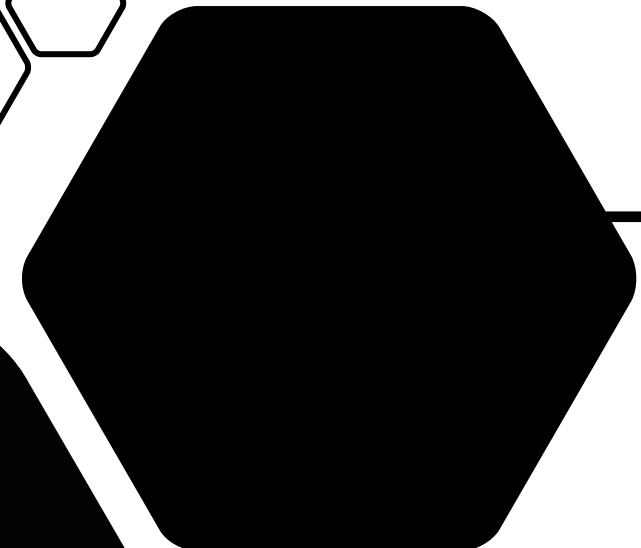
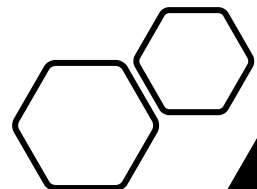

Thank you

Use Code: DEVENDRAPOONIA to get 10% off on Plus Subscription